



**CADDY CORPORATION**

---

Food Service Equipment

Air Systems

# Utility Make-Up Tables

**Utility Make-Up Tables**  
Regular or Slimline

- Rigid construction
- Stainless steel
- Easy to clean
- Provides good working surface

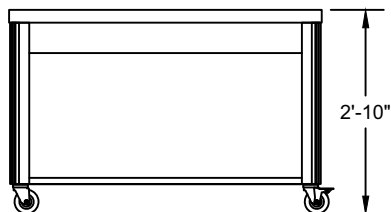
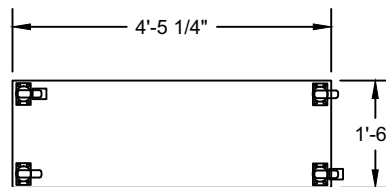
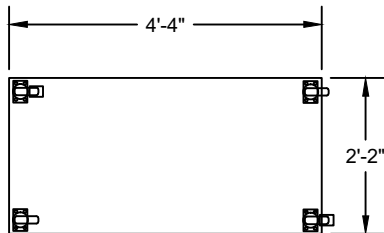
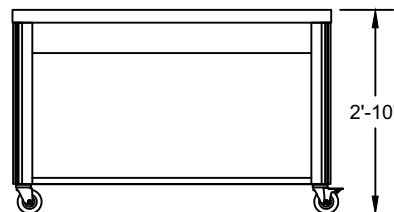
TF-600  
RegularTF-610  
Slimline**General Specifications**

Utility Make-Up Table to be Caddy Corporation model TF-\_\_\_\_\_.

Solid top to be reinforced 18 gauge stainless steel turned down into 2" wide channel edges with corners welded.

Frame structure to consist of 18 gauge stainless steel formed pedestals to be reinforced with 16 gauge stainless steel channels, to have full height extruded plastic vertical bumpers. Body enclosure to be 16 gauge stainless steel with 18 gauge stainless steel reinforced undershelf. Casters are to be 4" diameter heavy duty, double ball bearing, swivel type with polyurethane tires. Two casters to be provided with foot brakes.

Unit to be provided with the following accessories:

**Accessories**

- A-15 (A-16)\*** - Push Handle to be 1" O.D. 16 gauge stainless steel tubing with two 16 gauge stainless steel support brackets and 3" neoprene donut bumpers.
- A-69 (A-88)\*** - Folding Tray Slide To be 1" square 16 gauge stainless steel tubing, 10" overall width, welded to intermediate lateral supports and mounted on folding brackets. Slide to be removable.

Accessories continued:

- A-73 (A-90)\*** - Folding Work Shelf to be 16 gauge stainless steel with all edges turned down and welded corners, 10" overall width, mounted on folding brackets. Shelf to be removable.
- A-65 (A-86)\*** - Overshelf to be 16 gauge stainless steel, 10" wide with channel edges. Supports to be 1" x  $\frac{1}{4}$ " flat bar. Shelf to be located rear of unit 15" above work top.
- A-61 (A-84)\*** - Sneeze Protector\*\* to be  $\frac{3}{16}$ " clear polycarbonate plastic, suspended from 16 gauge stainless steel overshelf.
- ACC-52** - Vertical corner bumpers only. Easy to replace. (Add 1  $\frac{1}{4}$ " to length and width)

\* Use number in parentheses when ordering for TF-610 Slimline

\*\* Includes overshelf

**CADDY CORPORATION**  
509 Sharptown Road P.O. Box 345  
Bridgeport, NJ 08014-0345  
Tel: 856-467-4222 Fax: 856-467-5511  
internet: www.caddycorp.com

**Utility Make-Up Table****Bread, Toast, Rolls**

PROJECT:

LOCATION:

- T-790 features a solid top shelf for toasters and roll warmer\*

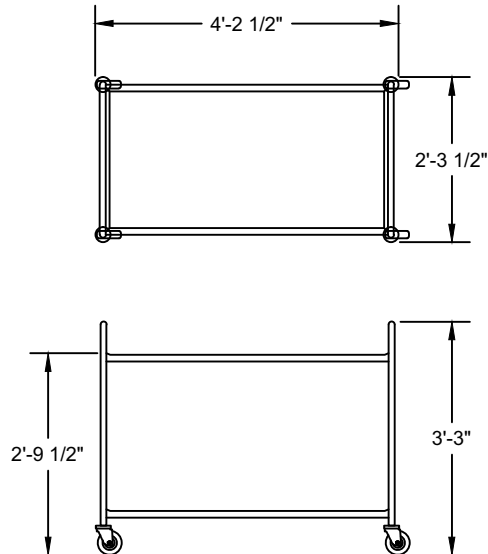

T-790

\* Toasters and roll warmer not included

**General Specifications**

Utility Make-Up Table to be Caddy Corporation model T-790.

Frame to be 1" O.D. 16 gauge stainless steel tubing and fitted with 4" diameter heavy-duty swivel type casters with  $\frac{3}{4}$ " stems and polyurethane tires.

Shelves to have raised rounded edges on all sides with all corners continuously welded to legs at all contact points. Both shelves to be reinforced with stainless steel channels. Lower shelf to accommodate a two drawer roll warmer.

Unit to be provided with the following accessories:

**Accessories**

- ACC-41** - Caster brakes on two diagonal casters.
- ACC-38** - Circular bumpers. (Add 4" to length and width)

**CADDY CORPORATION**  
 509 Sharptown Road P.O. Box 345  
 Bridgeport, NJ 08014-0345  
 Tel: 856-467-4222 Fax: 856-467-5511  
 internet: www.caddycorp.com

## Utility Caddys All-Purpose Trucks



ITEM NO:

PROJECT:

LOCATION:

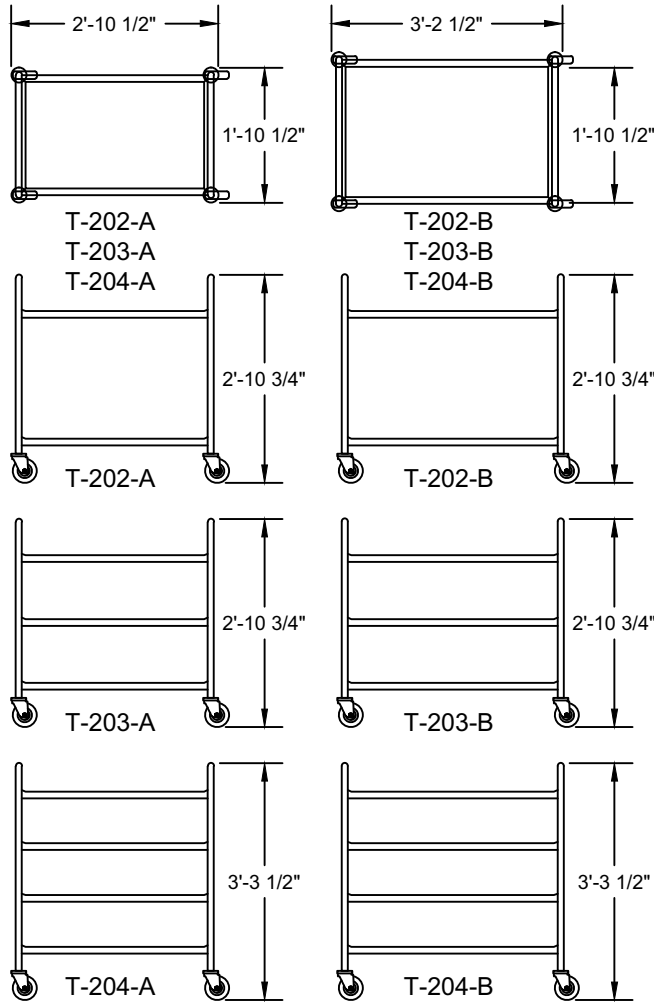

### General Specifications

Utility Caddy to be Caddy Corporation model \_\_\_\_\_.

Frame to be of 1" O.D. 16 gauge stainless steel tubing. Unit to have two shelves. Shelves to be 18 gauge stainless steel with raised rounded edges on all sides, flanged down to form a 1 1/2" wide channel. Shelf corners shaped to fit contour of tubular frame and continuously welded to each leg at all contact points which eliminates unsanitary crevices. Both shelves to be reinforced with stainless steel channels.

Casters to be 4" diameter heavy-duty swivel type with 3/4" stems and polyurethane tires.

Unit to be provided with the following accessories:

### Accessories

- ACC-38** - Circular bumpers. (Add 4" to length and width)
- ACC-41** - Caster brakes on two diagonal casters.
- ACC-63** - 5" diameter swivel casters with polyurethane tires in lieu of 4" diameter swivel casters. (Add 1 1/8" to height)
- PL-1520** - 15" x 20" x 5" plastic tote box for napkin wrapped silverware.

### Correctional Utility Caddy

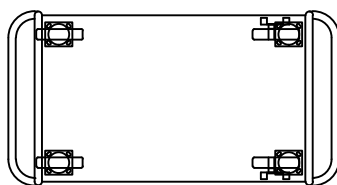

T-202-C

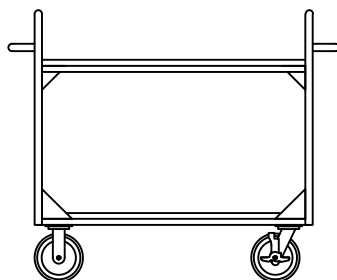

T-202-C

### General Specifications

Correctional Utility Caddy to be Caddy Corporation model T-202-C.

Frame to be of 1 1/4" O.D. 16 gauge stainless steel tubing reinforced with 12 gauge stainless steel corner gussets. Unit to have two shelves. Shelves to be 12 gauge stainless steel with 1" raised edge on three sides and 1" turned down edge on the front. Shelves and gussets to be continuously welded at corners which eliminates unsanitary crevices. Both shelves to be reinforced with 12 gauge stainless steel channels. Unit to have a 1 1/4" O.D. 16 gauge stainless steel tubular handle at each end that wraps around the rear creating a back stop.

Casters to be 8" diameter heavy-duty, semi-pneumatic, modulus-type tread. Two to be swivel type and two to be rigid type. Swivel type casters to be provided with foot brakes.

**CADDY CORPORATION**  
 509 Sharptown Road P.O. Box 345  
 Bridgeport, NJ 08014-0345  
 Tel: 856-467-4222 Fax: 856-467-5511  
 internet: www.caddycorp.com