



CADDY CORPORATION

Food Service Equipment

Air Systems

Product Catalog 2025

Conveyors



Tray Make-Up
Banqueting Systems
Custom Accumulators
Soiled Dish Room
Conveyors and Design

Cart and Support Equipment



Tray Delivery Carts
POD Systems
Custom Fabrication
Hot and Cold Wells

Kitchen Ventilation Systems



Baffle | Cartridge | UVC
Low Air Volume | DCV
Architectural Design
Ecology Units

Utility Distribution Systems



Island | Wall | Custom
Ceiling | Mobile
Quick-Disconnect Fittings
Safe Cost-effective
Flexibility

Manufacturers of...

Tray Make-Up Conveyor Systems

Soiled Tray Conveyors Systems

Kitchen Ventilation Systems

Utility Distribution Systems

Self-Leveling Dispensers

Transfer & Storage Caddys

...and more.



CADDY CORPORATION

509 Sharptown Road P.O. Box 345

Bridgeport, NJ 08014-0345

Tel: 856-467-4222 Fax: 856-467-5511

internet: www.caddycorp.com



CADDY CORPORATION

Food Service Equipment

Air Systems

Commercial Kitchen Exhaust Systems

Model PB

Baffle Filter Style

CADDY Air Systems

Model PB-C-W Dry Filter Ventilator

ITEM NO:

PROJECT:

LOCATION:

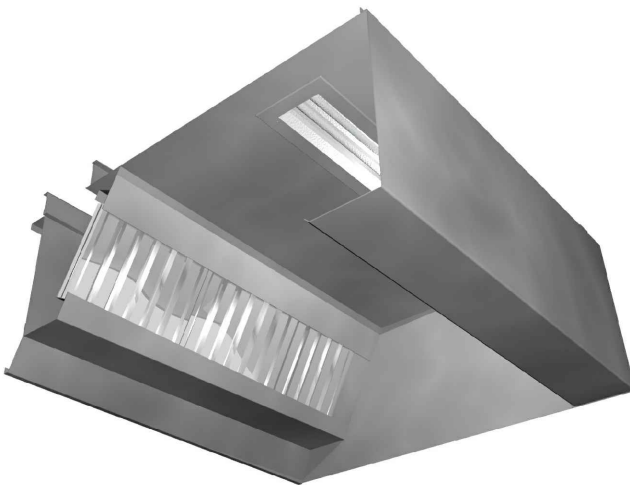

General Specifications

Furnish CADDY *AirSystems* Exhaust Ventilator Model **PB-C-W** as shown on the plans and as described in the following specifications.

General

Exhaust ventilator shall be constructed of 18 gauge type 300 series stainless steel. All exposed surfaces to have a #4 finish. Construction to meet all requirements of NFPA 96 and NSF Standard No. 2. To include necessary hanger brackets at front and rear suspending from building overhead structure.

Description

The CADDY *AirSystems* Model "PB" Series ventilator is a dry filter type and is ETL listed under the standards set forth in UL 710 "Exhaust Hoods for Commercial Cooking Equipment". This ventilator is 90% grease extraction efficient when operated and maintained in accordance with design specifications. Filters to be UL Classified stainless steel baffle type. This high efficiency is accomplished by utilizing removable stainless steel baffle filters containing a series of horizontal, self-draining baffles. As the air is drawn around the baffles, the grease, dust and lint particles are slung from the airstream by centrifugal force. As the liquefied grease is extracted, it is drained off via a trough into grease collection containers at each end of the ventilator. At the end of the cooking day or at scheduled intervals, the filters are removed for cleaning without having to climb up or onto the cooking equipment. Once removed, the filters can be washed either in a dishwasher or soaked and rinsed off in a pot sink. Each filter is a maximum of 19-1/2" long. Ventilator can also be equipped with an optional fusible link or thermostatically activated fire damper assembly.

Application

Wall mounted exhaust only canopy style for use over all types of cooking equipment.

Light Fixtures

All light fixtures shall be pre-wired to a single connection point. Ventilators built in multiple sections to be furnished with junction boxes for ease of field connection by the electrical trades. Light bulbs furnished and installed by the Kitchen Equipment Contractor.

Exhaust Fans

Exhaust fans are to be provided and installed by others in compliance with local codes. **Fans should be induced draft, squirrel cage design, equipped with backward inclined blades.**

Fire Protection

NFPA 96 and local codes require a fire extinguishing system for protection of the duct collar and plenum of all ventilators, as well as for the protection of various cooking appliances such as deep fat fryers, griddles, ranges, and broilers, which may be a source of ignition of grease. Consult factory and local fire officials for exact requirements. UL Listed fire protection systems may be pre-piped by Caddy at the time of manufacture, assuring concealment of piping and detectors.

Approvals

Ventilator shall be ETL Listed, listed by NSF and be in accordance with all of the recommendations set forth by NFPA 96. All ventilators must meet all applicable codes.

 **CADDY CORPORATION**
509 Sharptown Road P.O. Box 345
Bridgeport, NJ 08014-0345
Tel: 856-467-4222 Fax: 856-467-5511
internet: www.caddycorp.com



MODEL:

PB-C-W - - -

ADD THE OVERALL LENGTH (IN INCHES) OF THE VENTILATOR AFTER MODEL DESIGNATION

DAMPER TYPE
ND - NO DAMPER
FL - FUSIBLE LINK
T - THERMOSTAT

ADD THE OVERALL WIDTH (IN INCHES) OF THE VENTILATOR AFTER MODEL DESIGNATION

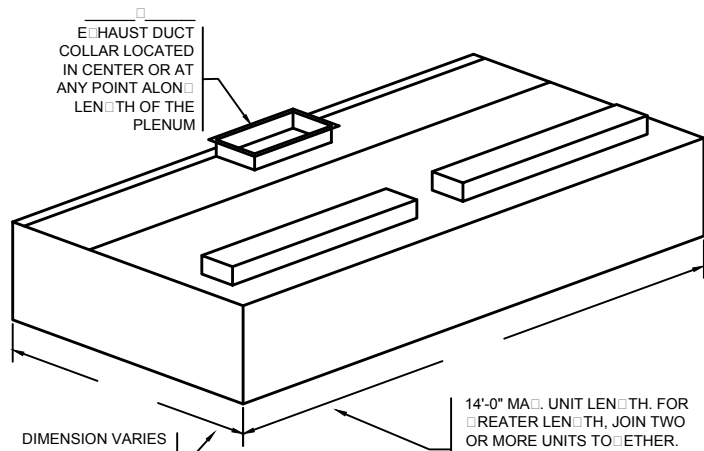

DIMENSION VARIES WITH DEPTH OF THE EQUIPMENT AND REQUIRED OVERHANG

14'-0" MAX. UNIT LENGTH. FOR GREATER LENGTH, JOIN TWO OR MORE UNITS TOGETHER. ALLOW 6" MIN. OVERHANG AT EACH END. IF CHARBROILER IS AT END, OVERHANG 12"

STANDARD LIGHT FIXTURES
() 100 WATT INCANDESCENT
() RECESSED INCANDESCENT
() RECESSED FLUORESCENT
(IF RECESSED FLUORESCENT SPECIFY SIZE)

CONSULT FACTORY FOR NON-STANDARD HEIGHTS
12" MIN. FRONT OVERHANG
6" MIN. SIDE OVERHANG
(12" MIN. SIDE OVERHANG FOR CHARBROILER)

ITEM # _____
EST. WEIGHT _____
LENGTH _____
WIDTH _____
HEIGHT _____
EXHAUST-CFM _____
DUCT SIZE _____
S.P. _____

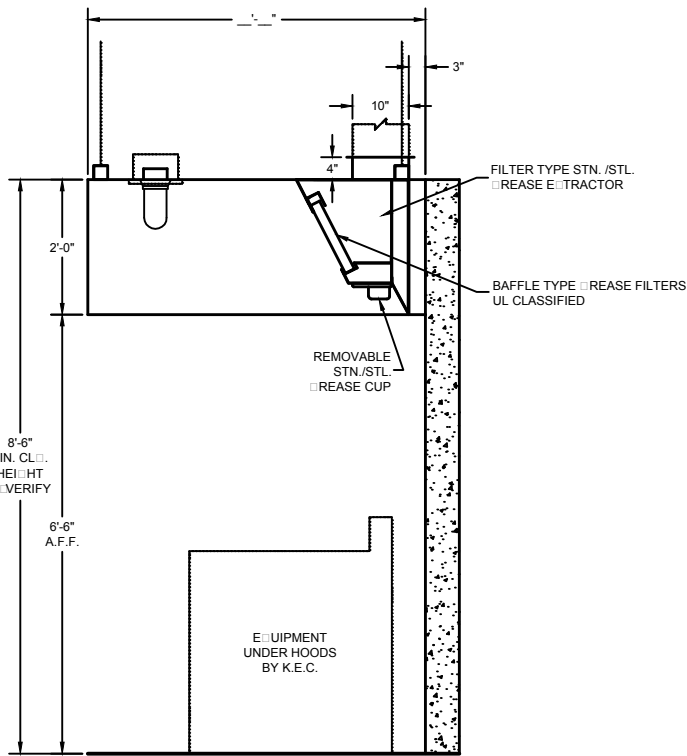

DRAWINGS NOT TO SCALE

ENGINEERING DATA

Ventilator Length

Maximum ventilator length in a single section is 14'-0". For lengths greater than 14'-0", join two or more sections. Verify access conditions into building and kitchen space prior to length selection.

Ventilator Hanging Weight

Wt./lineal ft. Lbs. 75

NOTE: Refer to **CADDY AirSystems**

Master Engineering Data Sheet in engineering data section for determining light, medium, and heavy duty cooking equipment, C.F.M. requirements (exhaust and supply), duct collar sizes and static pressure requirements.

Electrical Requirements

Light fixtures to be powered by a 120/1/60 circuit.

Mechanical Requirements

The volume of exhaust required is a function of the type of cooking equipment served by the ventilator, and the type and volume of product cooked. Refer to the **CADDY AirSystems**

Master Engineering Data Chart to determine exhaust volume, duct collar sizes, static pressure drop.



CADDY Air Systems

Model PB-C-W-PA Dry Filter Ventilator

ITEM NO:

PROJECT:

LOCATION:

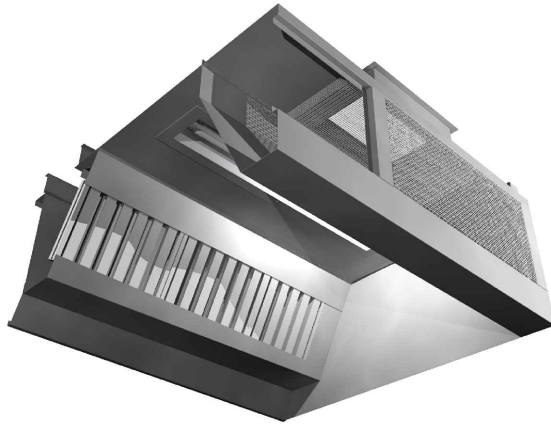

General Specifications

Furnish CADDY *AirSystems* Exhaust Ventilator Model **PB-C-W-PA** as shown on the plans and as described in the following specifications.

General

Exhaust ventilator shall be constructed of 18 gauge type 300 series stainless steel. All exposed surfaces to have a #4 finish. Construction to meet all requirements of NFPA 96 and NSF Standard No. 2. To include necessary hanger brackets at front and rear suspending from building overhead structure.

Description

The CADDY *AirSystems* Model "PB" Series ventilator is a dry filter type and is ETL listed under the standards set forth in UL 710 "Exhaust Hoods for Commercial Cooking Equipment".

This ventilator is 90% grease extraction efficient when operated and maintained in accordance with design specifications. Filters to be UL Classified stainless steel baffle type. This high efficiency is accomplished by utilizing removable stainless steel baffle filters containing a series of horizontal, self-draining baffles. As the air is drawn around the baffles, the grease, dust and lint particles are slung from the airstream by centrifugal force. As the liquefied grease is extracted, it is drained off via a trough into grease collection containers at each end of the ventilator. At the end of the cooking day or at scheduled intervals, the filters are removed for cleaning without having to climb up or onto the cooking equipment. Once removed, the filters can be washed either in a dishwasher or soaked and rinsed off in a pot sink. Each filter is a maximum of 19-1/2" long. Ventilator can also be equipped with an optional fusible link or thermostatically activated fire damper assembly.

Make-Up Air (Front Face Discharge)

Ventilator shall have 40% open stainless steel perforated screens along front face for discharge of tempered make-up air. Supply volume is 80% or designed to the desired air balance.

Application

Wall mounted exhaust only canopy style for use over all types of cooking equipment.

Light Fixtures

All light fixtures shall be pre-wired to a single connection point. Ventilators built in multiple sections to be furnished with junction boxes for ease of field connection by the electrical trades. Light bulbs furnished and installed by the Kitchen Equipment Contractor.

Exhaust Fans

Exhaust fans are to be provided and installed by others in compliance with local codes. **Fans should be induced draft, squirrel cage design, equipped with backward inclined blades.**

Fire Protection

NFPA 96 and local codes require a fire extinguishing system for protection of the duct collar and plenum of all ventilators, as well as for the protection of various cooking appliances such as deep fat fryers, griddles, ranges, and broilers, which may be a source of ignition of grease. Consult factory and local fire officials for exact requirements. UL Listed fire protection systems may be pre-piped by Caddy at the time of manufacture, assuring concealment of piping and detectors.

Approvals

Ventilator shall be ETL Listed, listed by NSF and be in accordance with all of the recommendations set forth by NFPA 96. All ventilators must meet all applicable codes.

 **CADDY CORPORATION**
509 Sharptown Road P.O. Box 345
Bridgeport, NJ 08014-0345
Tel: 856-467-4222 Fax: 856-467-5511
internet: www.caddycorp.com



MODEL:

PB-C-W-PA---

ADD THE OVERALL LENGTH (IN INCHES) OF THE VENTILATOR AFTER MODEL DESIGNATION

DAMPER TYPE
 ND - NO DAMPER
 FL - FUSIBLE LINK
 T - THERMOSTAT

ADD THE OVERALL WIDTH (IN INCHES) OF THE VENTILATOR AFTER MODEL DESIGNATION

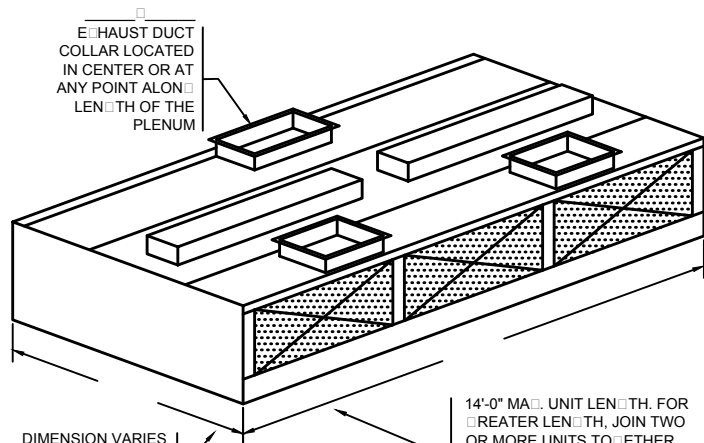

DIMENSION VARIES WITH DEPTH OF THE EQUIPMENT AND REQUIRED OVERHANG

14'-0" MAX. UNIT LENGTH. FOR GREATER LENGTH, JOIN TWO OR MORE UNITS TOGETHER. ALLOW 6" MIN. OVERHANG AT EACH END. IF CHARBROILER IS AT END, OVERHANG 12"

STANDARD LIGHT FIXTURES
 100 WATT INCANDESCENT
 RECESSED INCANDESCENT
 RECESSED FLUORESCENT
 (IF RECESSED FLUORESCENT SPECIFY SIZE)

CONSULT FACTORY FOR NON-STANDARD HEIGHTS
 12" MIN. FRONT OVERHANG
 6" MIN. SIDE OVERHANG (12" MIN. SIDE OVERHANG FOR CHARBROILER)

ITEM # _____
 EST. WEIGHT _____
 LENGTH _____
 WIDTH _____
 HEIGHT _____
 EXHAUST-CFM _____
 DUCT SIZE _____
 S.P. _____

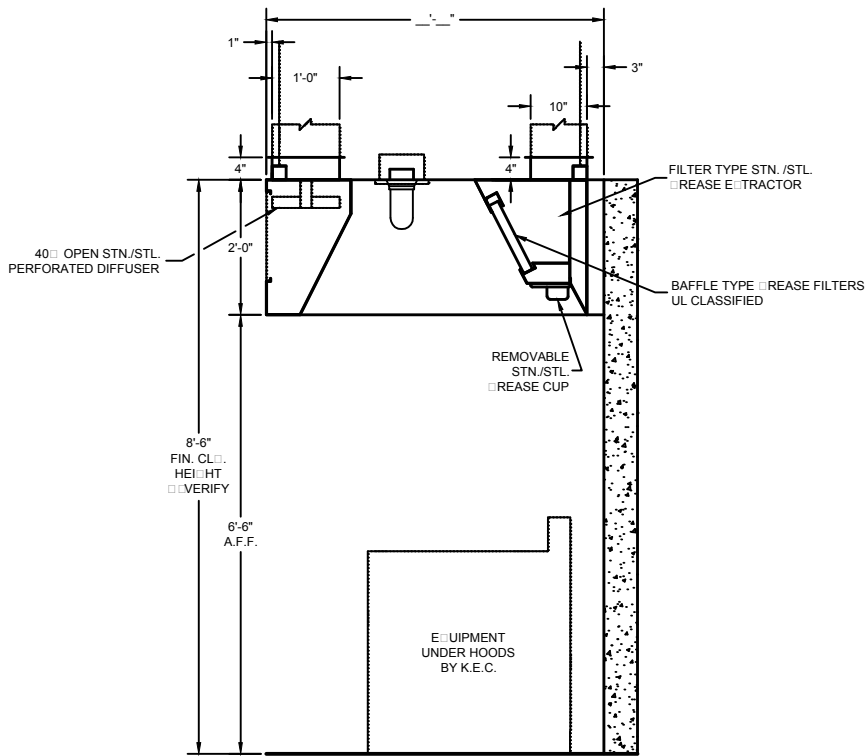

DRAWINGS NOT TO SCALE

ENGINEERING DATA

Ventilator Length

Maximum ventilator length in a single section is 14'-0". For lengths greater than 14'-0", join two or more sections. Verify access conditions into building and kitchen space prior to length selection.

Ventilator Hanging Weight

Wt./lineal ft. Lbs. 90

NOTE: Refer to CADDY AirSystems

Master Engineering Data Sheet in engineering data section for determining light, medium, and heavy duty cooking equipment, C.F.M. requirements (exhaust and supply), duct collar sizes and static pressure requirements.

Electrical Requirements

Light fixtures to be powered by a 120/1/60 circuit.

Mechanical Requirements

The volume of exhaust required is a function of the type of cooking equipment served by the ventilator, and the type and volume of product cooked. Refer to the **CADDY AirSystems**

Master Engineering Data Chart to determine exhaust volume, duct collar sizes, static pressure drop.



CADDY Air Systems

ITEM NO:

Model PB-C-W Dry Filter Ventilator - With Ceiling Supply Plenum

PROJECT:

LOCATION:

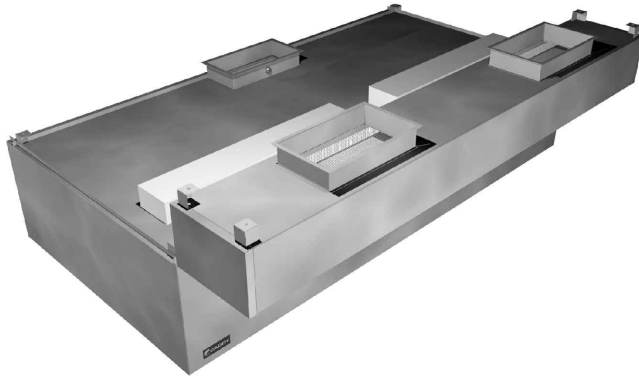

General Specifications

Furnish CADDY **AirSystems** Exhaust Ventilator Model **PB-C-W** as shown on the plans and as described in the following specifications.

General

Exhaust ventilator shall be constructed of 18 gauge type 300 series stainless steel. All exposed surfaces to have a #4 finish. Construction to meet all requirements of NFPA 96 and NSF Standard No. 2. To include necessary hanger brackets at front and rear suspending from building overhead structure.

Description

The CADDY **AirSystems** Model "PB" Series ventilator is a dry filter type and is ETL listed under the standards set forth in UL 710 "Exhaust Hoods for Commercial Cooking Equipment".

This ventilator is 90% grease extraction efficient when operated and maintained in accordance with design specifications. Filters to be UL Classified stainless steel baffle type. This high efficiency is accomplished by utilizing removable stainless steel baffle filters containing a series of horizontal, self-draining baffles. As the air is drawn around the baffles, the grease, dust and lint particles are slung from the airstream by centrifugal force. As the liquefied grease is extracted, it is drained off via a trough into grease collection containers at each end of the ventilator. At the end of the cooking day or at scheduled intervals, the filters are removed for cleaning without having to climb up or onto the cooking equipment. Once removed, the filters can be washed either in a dishwasher or soaked and rinsed off in a pot sink. Each filter is a maximum of 19-1/2" long. Ventilator can also be equipped with an optional fusible link or thermostatically activated fire damper assembly.

Make-Up Air (Perimeter Down Discharge)

Ventilator shall have 40% open stainless steel perforated screens for downward discharge of tempered make-up air. Supply volume is 80% or designed to the desired air balance.

Application

Wall mounted exhaust only canopy style for use over all types of cooking equipment.

Light Fixtures

All light fixtures shall be pre-wired to a single connection point. Ventilators built in multiple sections to be furnished with junction boxes for ease of field connection by the electrical trades. Light bulbs furnished and installed by the Kitchen Equipment Contractor.

Exhaust Fans

Exhaust fans are to be provided and installed by others in compliance with local codes. **Fans should be induced draft, squirrel cage design, equipped with backward inclined blades.**

Fire Protection

NFPA 96 and local codes require a fire extinguishing system for protection of the duct collar and plenum of all ventilators, as well as for the protection of various cooking appliances such as deep fat fryers, griddles, ranges, and broilers, which may be a source of ignition of grease. Consult factory and local fire officials for exact requirements. UL Listed fire protection systems may be pre-piped by Caddy at the time of manufacture, assuring concealment of piping and detectors.

Approvals

Ventilator shall be ETL Listed, listed by NSF and be in accordance with all of the recommendations set forth by NFPA 96. All ventilators must meet all applicable codes.

 **CADDY CORPORATION**
509 Sharptown Road P.O. Box 345
Bridgeport, NJ 08014-0345
Tel: 856-467-4222 Fax: 856-467-5511
internet: www.caddycorp.com



MODEL:

PB-C-W- - -

ADD THE OVERALL LENGTH (IN INCHES) OF THE VENTILATOR AFTER MODEL DESIGNATION

DAMPER TYPE
ND - NO DAMPER
FL - FUSIBLE LINK
T - THERMOSTAT

ADD THE OVERALL WIDTH (IN INCHES) OF THE VENTILATOR AFTER MODEL DESIGNATION

EXHAUST DUCT COLLAR LOCATED IN CENTER OR AT ANY POINT ALONG LENGTH OF THE PLENUM

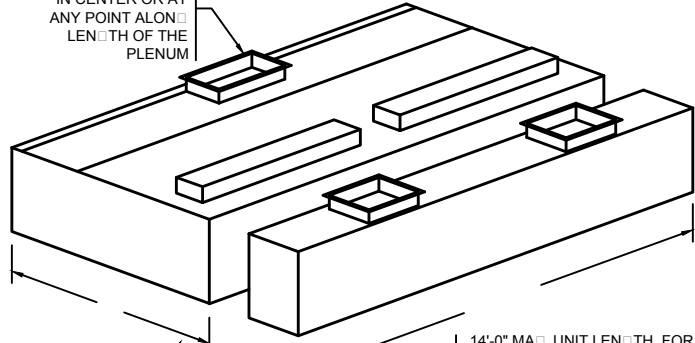

14'-0" MAX. UNIT LENGTH. FOR GREATER LENGTH, JOIN TWO OR MORE UNITS TOGETHER. ALLOW 6" MIN. OVERHANG AT EACH END. IF CHARBROILER IS AT END, OVERHANG 12"

DIMENSION VARIES WITH DEPTH OF THE EQUIPMENT AND REQUIRED OVERHANG

STANDARD LIGHT FIXTURES
() 100 WATT INCANDESCENT
() RECESSED INCANDESCENT
() RECESSED FLUORESCENT (IF RECESSED FLUORESCENT SPECIFY SIZE)

CONSULT FACTORY FOR NON-STANDARD HEIGHTS
22" MIN. FRONT OVERHANG
6" MIN. SIDE OVERHANG (12" MIN. SIDE OVERHANG FOR CHARBROILER)

ITEM # _____
EST. WEIGHT _____
LENGTH _____
WIDTH _____
HEIGHT _____
EXHAUST-CFM _____
DUCT SIZE _____
S.P. _____

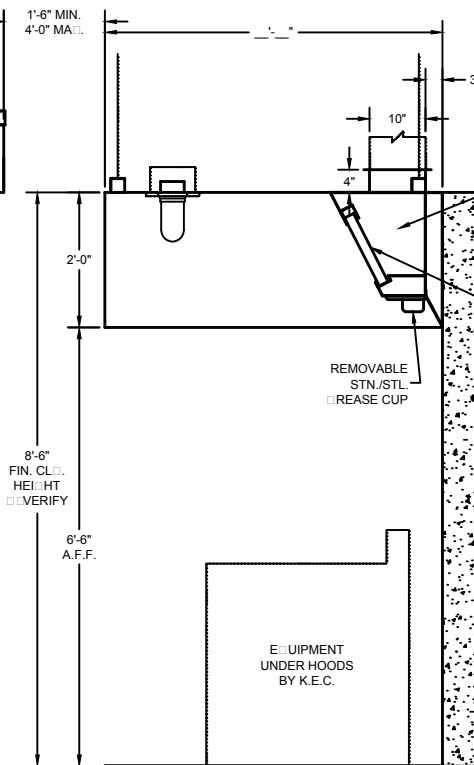
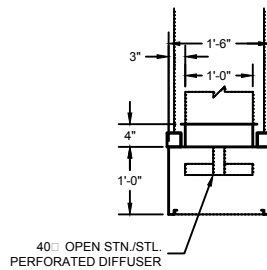

DRAWINGS NOT TO SCALE

ENGINEERING DATA

Ventilator Length

Maximum ventilator length in a single section is 14'-0". For lengths greater than 14'-0", join two or more sections. Verify access conditions into building and kitchen space prior to length selection.

Ventilator Hanging Weight

Wt./lineal ft. Lbs. 90

NOTE: Refer to **CADDY AirSystems**

Master Engineering Data Sheet in engineering data section for determining light, medium, and heavy duty cooking equipment, C.F.M. requirements (exhaust and supply), duct collar sizes and static pressure requirements.

Electrical Requirements

Light fixtures to be powered by a 120/1/60 circuit.

Mechanical Requirements

The volume of exhaust required is a function of the type of cooking equipment served by the ventilator, and the type and volume of product cooked. Refer to the **CADDY AirSystems**

Master Engineering Data Chart to determine exhaust volume, duct collar sizes, static pressure drop.



Model PB-C-I Dry Filter Ventilator

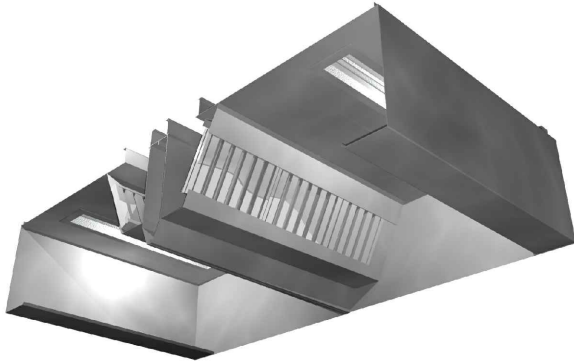

General Specifications

Furnish CADDY *AirSystems* Exhaust Ventilator Model **PB-C-I** as shown on the plans and as described in the following specifications.

General

Exhaust ventilator shall be constructed of 18 gauge type 300 series stainless steel. All exposed surfaces to have a #4 finish. Construction to meet all requirements of NFPA 96 and NSF Standard No. 2. To include necessary hanger brackets at front and rear suspending from building overhead structure.

Description

The CADDY *AirSystems* Model "PB" Series ventilator is a dry filter type and is ETL listed under the standards set forth in UL 710 "Exhaust Hoods for Commercial Cooking Equipment". This ventilator is 90% grease extraction efficient when operated and maintained in accordance with design specifications. Filters to be UL Classified stainless steel baffle type. This high efficiency is accomplished by utilizing removable stainless steel baffle filters containing a series of horizontal, self-draining baffles. As the air is drawn around the baffles, the grease, dust and lint particles are slung from the airstream by centrifugal force. As the liquefied grease is extracted, it is drained off via a trough into grease collection containers at each end of the ventilator. At the end of the cooking day or at scheduled intervals, the filters are removed for cleaning without having to climb up or onto the cooking equipment. Once removed, the filters can be washed either in a dishwasher or soaked and rinsed off in a pot sink. Each filter is a maximum of 19-1/2" long. Ventilator can also be equipped with an optional fusible link or thermostatically activated fire damper assembly.

Application

Island mounted exhaust only canopy style for use over all types of cooking equipment.

Light Fixtures

All light fixtures shall be pre-wired to a single connection point. Ventilators built in multiple sections to be furnished with junction boxes for ease of field connection by the electrical trades. Light bulbs furnished and installed by the Kitchen Equipment Contractor.

Exhaust Fans

Exhaust fans are to be provided and installed by others in compliance with local codes. **Fans should be induced draft, squirrel cage design, equipped with backward inclined blades.**

Fire Protection

NFPA 96 and local codes require a fire extinguishing system for protection of the duct collar and plenum of all ventilators, as well as for the protection of various cooking appliances such as deep fat fryers, griddles, ranges, and broilers, which may be a source of ignition of grease. Consult factory and local fire officials for exact requirements. UL Listed fire protection systems may be pre-piped by Caddy at the time of manufacture, assuring concealment of piping and detectors.

Approvals

Ventilator shall be ETL Listed, listed by NSF and be in accordance with all of the recommendations set forth by NFPA 96. All ventilators must meet all applicable codes.

 **CADDY CORPORATION**
509 Sharptown Road P.O. Box 345
Bridgeport, NJ 08014-0345
Tel: 856-467-4222 Fax: 856-467-5511
internet: www.caddycorp.com



MODEL:

PB-C-I---

ADD THE OVERALL LENGTH (IN INCHES) OF THE VENTILATOR AFTER MODEL DESIGNATION

DAMPER TYPE
ND - NO DAMPER
FL - FUSIBLE LINK
T - THERMOSTAT

ADD THE OVERALL WIDTH (IN INCHES) OF THE VENTILATOR AFTER MODEL DESIGNATION

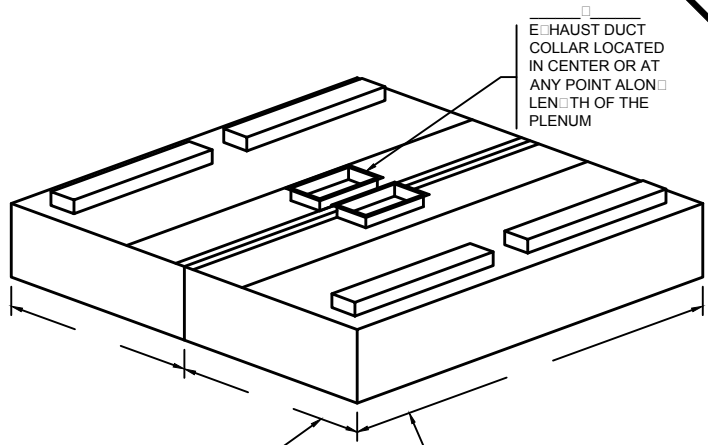

EXHAUST DUCT COLLAR LOCATED IN CENTER OR AT ANY POINT ALONG LENGTH OF THE PLENUM

DIMENSION VARIES WITH DEPTH OF THE EQUIPMENT AND REQUIRED OVERHANG

14'-0" MAX. UNIT LENGTH. FOR GREATER LENGTH, JOIN TWO OR MORE UNITS TOGETHER. ALLOW 6" MIN. OVERHANG AT EACH END. IF CHARBROILER IS AT END, OVERHANG 12"

STANDARD LIGHT FIXTURES
() 100 WATT INCANDESCENT
() RECESSED INCANDESCENT
() RECESSED FLUORESCENT
(IF RECESSED FLUORESCENT SPECIFY SIZE)

CONSULT FACTORY FOR NON-STANDARD HEIGHTS
12" MIN. FRONT OVERHANG
6" MIN. SIDE OVERHANG (12" MIN. SIDE OVERHANG FOR CHARBROILER)

ITEM # _____
EST. WEIGHT _____
LENGTH _____
WIDTH _____
HEIGHT _____
EXHAUST-CFM _____
DUCT SIZE _____
S.P. _____

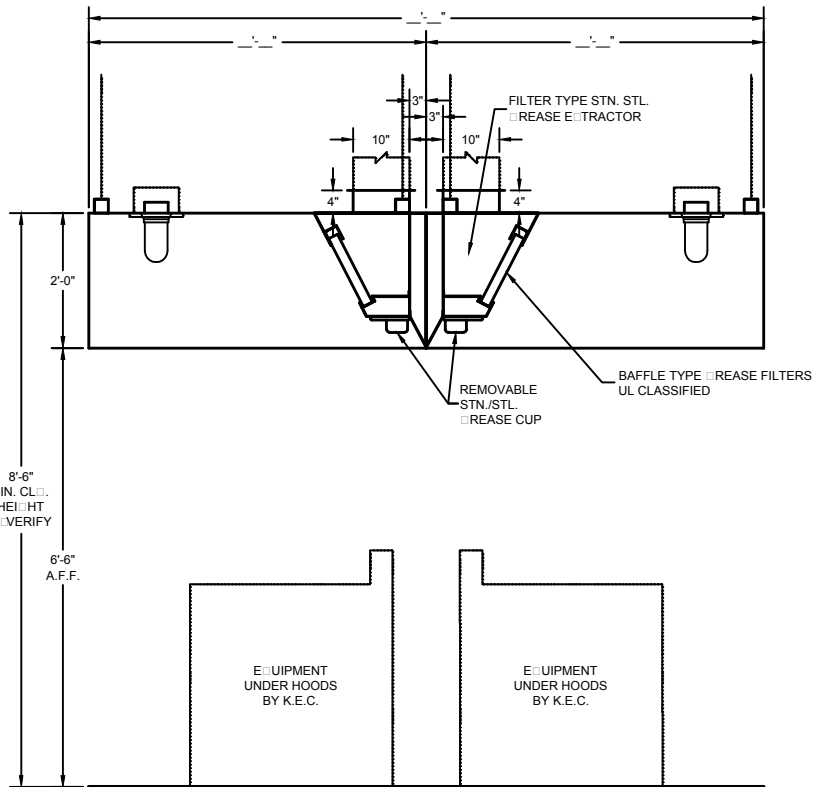

8'-6" FIN. CL. HEIGHT VERIFY

6'-6" A.F.F.

EQUIPMENT UNDER HOODS BY K.E.C.

EQUIPMENT UNDER HOODS BY K.E.C.

DRAWINGS NOT TO SCALE

ENGINEERING DATA

Ventilator Length

Maximum ventilator length in a single section is 14'-0". For lengths greater than 14'-0", join two or more sections. Verify access conditions into building and kitchen space prior to length selection.

Ventilator Hanging Weight

Wt./lineal ft. Lbs. 75

NOTE: Refer to **CADDY AirSystems**

Master Engineering Data Sheet in engineering data section for determining light, medium, and heavy duty cooking equipment, C.F.M. requirements (exhaust and supply), duct collar sizes and static pressure requirements.

Electrical Requirements

Light fixtures to be powered by a 120/1/60 circuit.

Mechanical Requirements

The volume of exhaust required is a function of the type of cooking equipment served by the ventilator, and the type and volume of product cooked. Refer to the **CADDY AirSystems**

Master Engineering Data Chart to determine exhaust volume, duct collar sizes, static pressure drop.



CADDY Air Systems

Model PB-C-I-PA Dry Filter Ventilator

ITEM NO:

PROJECT:

LOCATION:

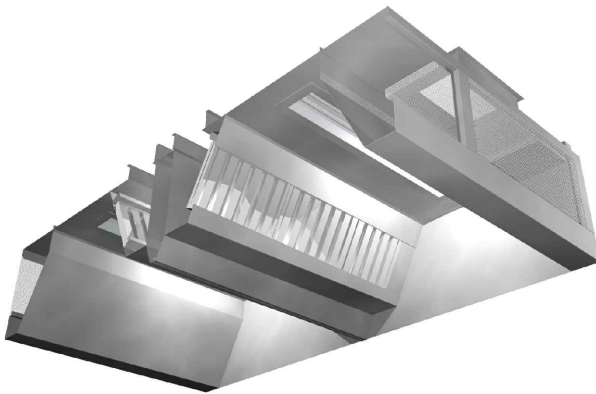
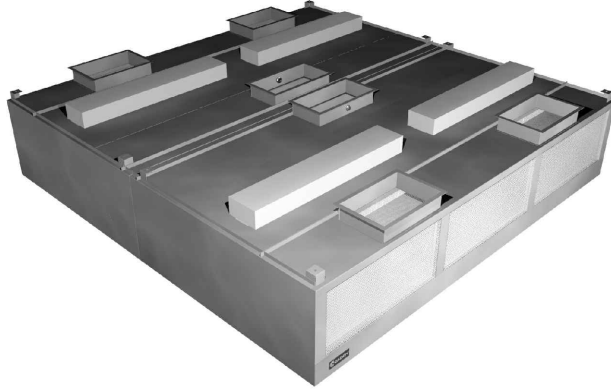

General Specifications

Furnish CADDY AirSystems Exhaust Ventilator Model **PB-C-I-PA** as shown on the plans and as described in the following specifications.

General

Exhaust ventilator shall be constructed of 18 gauge type 300 series stainless steel. All exposed surfaces to have a #4 finish. Construction to meet all requirements of NFPA 96 and NSF Standard No. 2. To include necessary hanger brackets at front and rear suspending from building overhead structure.

Description

The CADDY AirSystems Model "PB" Series ventilator is a dry filter type and is ETL listed under the standards set forth in UL 710 "Exhaust Hoods for Commercial Cooking Equipment".

This ventilator is 90% grease extraction efficient when operated and maintained in accordance with design specifications. Filters to be UL Classified stainless steel baffle type. This high efficiency is accomplished by utilizing removable stainless steel baffle filters containing a series of horizontal, self-draining baffles. As the air is drawn around the baffles, the grease, dust and lint particles are slung from the airstream by centrifugal force. As the liquefied grease is extracted, it is drained off via a trough into grease collection containers at each end of the ventilator. At the end of the cooking day or at scheduled intervals, the filters are removed for cleaning without having to climb up or onto the cooking equipment. Once removed, the filters can be washed either in a dishwasher or soaked and rinsed off in a pot sink. Each filter is a maximum of 19-1/2" long. Ventilator can also be equipped with an optional fusible link or thermostatically activated fire damper assembly.

Make-Up Air (Front Face Discharge)

Ventilator shall have 40% open stainless steel perforated screens along front face for discharge of tempered make-up air. Supply volume is 80% or designed to the desired air balance.

Application

Island style cooking applications for use over all types of cooking equipment where integral make-up air is required.

Light Fixtures

All light fixtures shall be pre-wired to a single connection point. Ventilators built in multiple sections to be furnished with junction boxes for ease of field connection by the electrical trades. Light bulbs furnished and installed by the Kitchen Equipment Contractor.

Exhaust Fans

Exhaust fans are to be provided and installed by others in compliance with local codes. **Fans should be induced draft, squirrel cage design, equipped with backward inclined blades.**

Fire Protection

NFPA 96 and local codes require a fire extinguishing system for protection of the duct collar and plenum of all ventilators, as well as for the protection of various cooking appliances such as deep fat fryers, griddles, ranges, and broilers, which may be a source of ignition of grease. Consult factory and local fire officials for exact requirements. UL Listed fire protection systems may be pre-piped by Caddy at the time of manufacture, assuring concealment of piping and detectors.

Approvals

Ventilator shall be ETL Listed, listed by NSF and be in accordance with all of the recommendations set forth by NFPA 96. All ventilators must meet all applicable codes.

 **CADDY CORPORATION**
509 Sharptown Road P.O. Box 345
Bridgeport, NJ 08014-0345
Tel: 856-467-4222 Fax: 856-467-5511
internet: www.caddycorp.com



MODEL:

PB-C-I-PA---

ADD THE OVERALL LENGTH (IN INCHES) OF THE VENTILATOR AFTER MODEL DESIGNATION

DAMPER TYPE
ND - NO DAMPER
FL - FUSIBLE LINK
T - THERMOSTAT

ADD THE OVERALL WIDTH (IN INCHES) OF THE VENTILATOR AFTER MODEL DESIGNATION

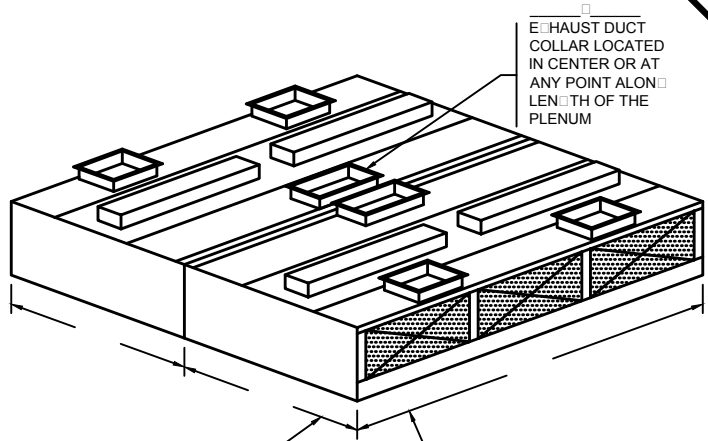

EXHAUST DUCT COLLAR LOCATED IN CENTER OR AT ANY POINT ALONG LENGTH OF THE PLENUM

DIMENSION VARIES WITH DEPTH OF THE EQUIPMENT AND REQUIRED OVERHANG

14'-0" MAX. UNIT LENGTH. FOR GREATER LENGTH, JOIN TWO OR MORE UNITS TOGETHER. ALLOW 6" MIN. OVERHANG AT EACH END. IF CHARBROILER IS AT END, OVERHANG 12"

STANDARD LIGHT FIXTURES
() 100 WATT INCANDESCENT
() RECESSED INCANDESCENT
() RECESSED FLUORESCENT
(IF RECESSED FLUORESCENT SPECIFY SIZE)

CONSULT FACTORY FOR NON-STANDARD HEIGHTS

12" MIN. FRONT OVERHANG

6" MIN. SIDE OVERHANG
(12" MIN. SIDE OVERHANG FOR CHARBROILER)

ITEM # _____
EST. WEIGHT _____
LENGTH _____
WIDTH _____
HEIGHT _____
EXHAUST-CFM _____
DUCT SIZE _____
S.P. _____

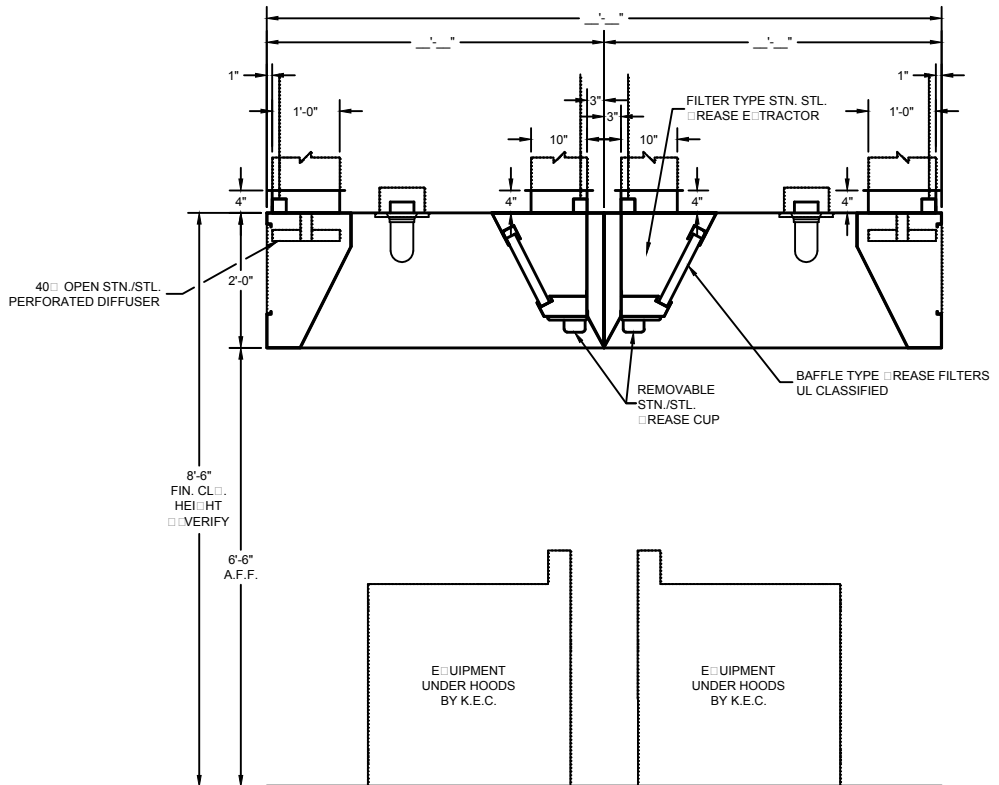

DRAWINGS NOT TO SCALE

ENGINEERING DATA

Ventilator Length

Maximum ventilator length in a single section is 14'-0". For lengths greater than 14'-0", join two or more sections. Verify access conditions into building and kitchen space prior to length selection.

Ventilator Hanging Weight

Wt./lineal ft. Lbs. 90

NOTE: Refer to **CADDY AirSystems**

Master Engineering Data Sheet in engineering data section for determining light, medium, and heavy duty cooking equipment, C.F.M. requirements (exhaust and supply), duct collar sizes and static pressure requirements.

Electrical Requirements

Light fixtures to be powered by a 120/1/60 circuit.

Mechanical Requirements

The volume of exhaust required is a function of the type of cooking equipment served by the ventilator, and the type and volume of product cooked. Refer to the **CADDY AirSystems**

Master Engineering Data Chart to determine exhaust volume, duct collar sizes, static pressure drop.



CADDY Air Systems

ITEM NO:

Model PB-C-I

Dry Filter Ventilator - With Ceiling Supply Plenum

PROJECT:

LOCATION:

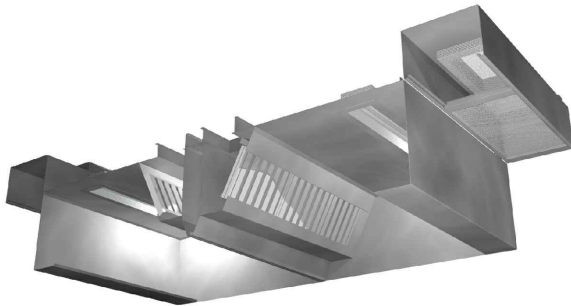
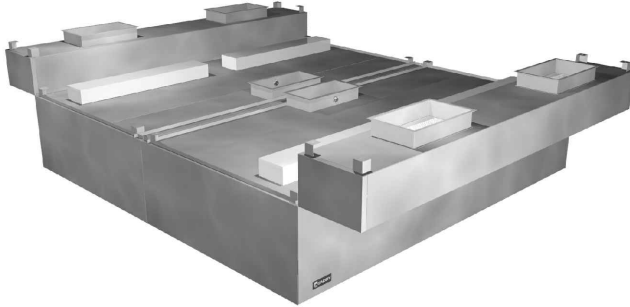

General Specifications

Furnish CADDY *AirSystems* Exhaust Ventilator Model **PB-C-I** as shown on the plans and as described in the following specifications.

General

Exhaust ventilator shall be constructed of 18 gauge type 300 series stainless steel. All exposed surfaces to have a #4 finish. Construction to meet all requirements of NFPA 96 and NSF Standard No. 2. To include necessary hanger brackets at front and rear suspending from building overhead structure.

Description

The CADDY *AirSystems* Model "PB" Series ventilator is a dry filter type and is ETL listed under the standards set forth in UL 710 "Exhaust Hoods for Commercial Cooking Equipment".

This ventilator is 90% grease extraction efficient when operated and maintained in accordance with design specifications. Filters to be UL Classified stainless steel baffle type. This high efficiency is accomplished by utilizing removable stainless steel baffle filters containing a series of horizontal, self-draining baffles. As the air is drawn around the baffles, the grease, dust and lint particles are slung from the airstream by centrifugal force. As the liquefied grease is extracted, it is drained off via a trough into grease collection containers at each end of the ventilator. At the end of the cooking day or at scheduled intervals, the filters are removed for cleaning without having to climb up or onto the cooking equipment. Once removed, the filters can be washed either in a dishwasher or soaked and rinsed off in a pot sink. Each filter is a maximum of 19-1/2" long. Ventilator can also be equipped with an optional fusible link or thermostatically activated fire damper assembly.

Make-Up Air (Perimeter Down Discharge)

Ventilator shall have 40% open stainless steel perforated screens for downward discharge of tempered make-up air. Supply volume is 80% or designed to the desired air balance.

Application

Island style cooking applications for use over all types of cooking equipment where integral make-up air is required.

Light Fixtures

All light fixtures shall be pre-wired to a single connection point. Ventilators built in multiple sections to be furnished with junction boxes for ease of field connection by the electrical trades. Light bulbs furnished and installed by the Kitchen Equipment Contractor.

Exhaust Fans

Exhaust fans are to be provided and installed by others in compliance with local codes. **Fans should be induced draft, squirrel cage design, equipped with backward inclined blades.**

Fire Protection

NFPA 96 and local codes require a fire extinguishing system for protection of the duct collar and plenum of all ventilators, as well as for the protection of various cooking appliances such as deep fat fryers, griddles, ranges, and broilers, which may be a source of ignition of grease. Consult factory and local fire officials for exact requirements. UL Listed fire protection systems may be pre-piped by Caddy at the time of manufacture, assuring concealment of piping and detectors.

Approvals

Ventilator shall be ETL Listed, listed by NSF and be in accordance with all of the recommendations set forth by NFPA 96. All ventilators must meet all applicable codes.

 **CADDY CORPORATION**
509 Sharptown Road P.O. Box 345
Bridgeport, NJ 08014-0345
Tel: 856-467-4222 Fax: 856-467-5511
internet: www.caddycorp.com



MODEL:

PB-C-I- [] - [] - []

ADD THE OVERALL LENGTH (IN INCHES) OF THE VENTILATOR AFTER MODEL DESIGNATION

DAMPER TYPE
 ND - NO DAMPER
 FL - FUSIBLE LINK
 T - THERMOSTAT

ADD THE OVERALL WIDTH (IN INCHES) OF THE VENTILATOR AFTER MODEL DESIGNATION

EXHAUST DUCT COLLAR LOCATED IN CENTER OR AT ANY POINT ALONG LENGTH OF THE PLENUM

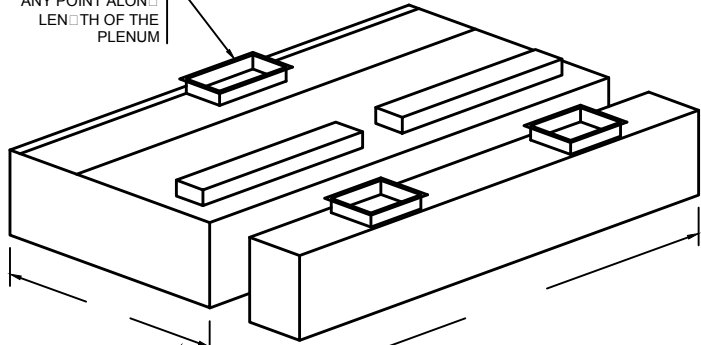

STANDARD LIGHT FIXTURES
 () 100 WATT INCANDESCENT
 () RECESSED INCANDESCENT
 () RECESSED FLUORESCENT
 (IF RECESSED FLUORESCENT SPECIFY SIZE)

CONSULT FACTORY FOR NON-STANDARD HEIGHTS
 22" MIN. FRONT OVERHANG
 6" MIN. SIDE OVERHANG
 (12" MIN. SIDE OVERHANG FOR CHARBROILER)

ITEM # _____
 EST. WEIGHT _____
 LENGTH _____
 WIDTH _____
 HEIGHT _____
 EXHAUST-CFM _____
 DUCT SIZE _____
 S.P. _____

DIMENSION VARIES WITH DEPTH OF THE EQUIPMENT AND REQUIRED OVERHANG

14'-0" MAX. UNIT LENGTH. FOR GREATER LENGTH, JOIN TWO OR MORE UNITS TOGETHER. ALLOW 6" MIN. OVERHANG AT EACH END. IF CHARBROILER IS AT END, OVERHANG 12"

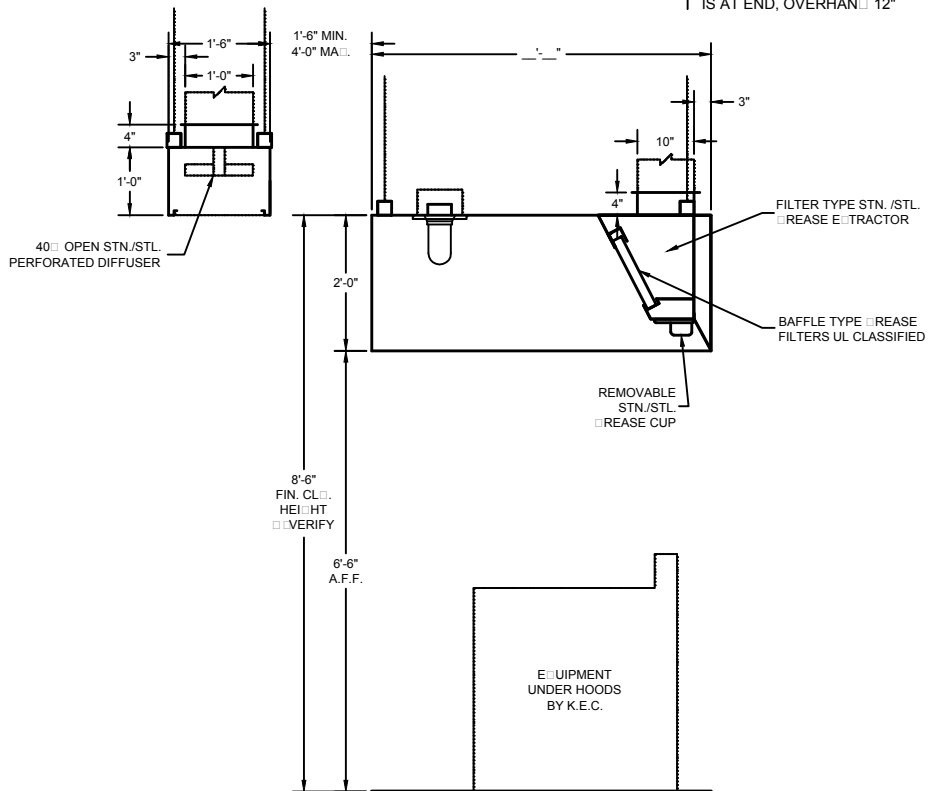

DRAWINGS NOT TO SCALE

ENGINEERING DATA

Ventilator Length

Maximum ventilator length in a single section is 14'-0". For lengths greater than 14'-0", join two or more sections. Verify access conditions into building and kitchen space prior to length selection.

Ventilator Hanging Weight

Wt./lineal ft.	Lbs.	90
----------------	------	----

NOTE: Refer to **CADDY AirSystems**

Master Engineering Data Sheet in engineering data section for determining light, medium, and heavy duty cooking equipment, C.F.M. requirements (exhaust and supply), duct collar sizes and static pressure requirements.

Electrical Requirements

Light fixtures to be powered by a 120/1/60 circuit.

Mechanical Requirements

The volume of exhaust required is a function of the type of cooking equipment served by the ventilator, and the type and volume of product cooked. Refer to the **CADDY AirSystems**

Master Engineering Data Chart to determine exhaust volume, duct collar sizes, static pressure drop.



Model PB-C-II Dry Filter Ventilator

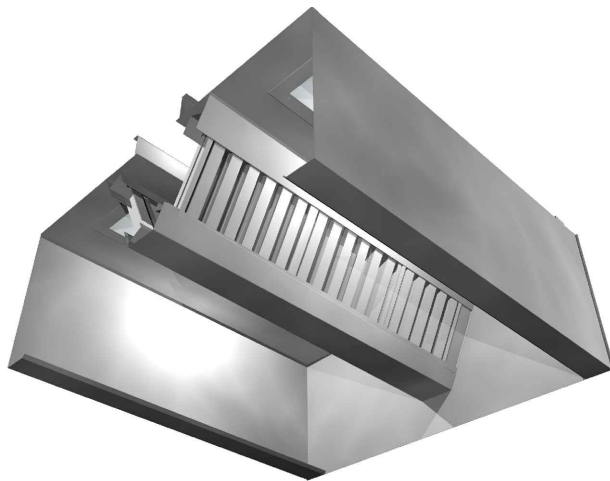
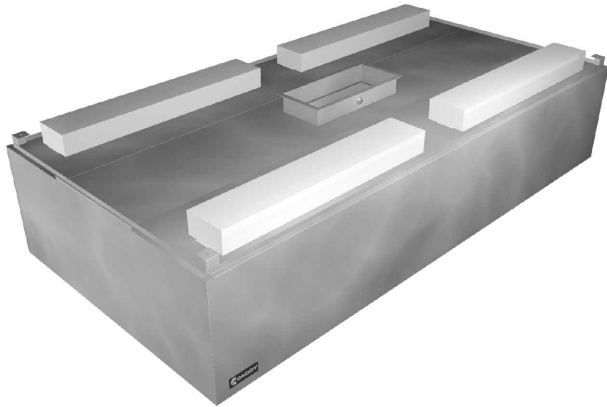

General Specifications

Furnish CADDY **AirSystems** Exhaust Ventilator Model **PB-C-II** as shown on the plans and as described in the following specifications.

General

Exhaust ventilator shall be constructed of 18 gauge type 300 series stainless steel. All exposed surfaces to have a #4 finish. Construction to meet all requirements of NFPA 96 and NSF Standard No. 2. To include necessary hanger brackets at front and rear suspending from building overhead structure.

Description

The CADDY **AirSystems** Model "PB" Series ventilator is a dry filter type and is ETL listed under the standards set forth in UL 710 "Exhaust Hoods for Commercial Cooking Equipment". This ventilator is 90% grease extraction efficient when operated and maintained in accordance with design specifications. Filters to be UL Classified stainless steel baffle type. This high efficiency is accomplished by utilizing removable stainless steel baffle filters containing a series of horizontal, self-draining baffles. As the air is drawn around the baffles, the grease, dust and lint particles are slung from the airstream by centrifugal force. As the liquefied grease is extracted, it is drained off via a trough into grease collection containers at each end of the ventilator. At the end of the cooking day or at scheduled intervals, the filters are removed for cleaning without having to climb up or onto the cooking equipment. Once removed, the filters can be washed either in a dishwasher or soaked and rinsed off in a pot sink. Each filter is a maximum of 19-1/2" long. Ventilator can also be equipped with an optional fusible link or thermostatically activated fire damper assembly.

Application

Island mounted exhaust only canopy style for use over all types of cooking equipment.

Light Fixtures

All light fixtures shall be pre-wired to a single connection point. Ventilators built in multiple sections to be furnished with junction boxes for ease of field connection by the electrical trades. Light bulbs furnished and installed by the Kitchen Equipment Contractor.

Exhaust Fans

Exhaust fans are to be provided and installed by others in compliance with local codes. **Fans should be induced draft, squirrel cage design, equipped with backward inclined blades.**

Fire Protection

NFPA 96 and local codes require a fire extinguishing system for protection of the duct collar and plenum of all ventilators, as well as for the protection of various cooking appliances such as deep fat fryers, griddles, ranges, and broilers, which may be a source of ignition of grease. Consult factory and local fire officials for exact requirements. UL Listed fire protection systems may be pre-piped by Caddy at the time of manufacture, assuring concealment of piping and detectors.

Approvals

Ventilator shall be ETL Listed, listed by NSF and be in accordance with all of the recommendations set forth by NFPA 96. All ventilators must meet all applicable codes.

 **CADDY CORPORATION**
509 Sharptown Road P.O. Box 345
Bridgeport, NJ 08014-0345
Tel: 856-467-4222 Fax: 856-467-5511
internet: www.caddycorp.com



MODEL:

PB-C-II---

ADD THE OVERALL LENGTH (IN INCHES) OF THE VENTILATOR AFTER MODEL DESIGNATION

DAMPER TYPE
 ND - NO DAMPER
 FL - FUSIBLE LINK
 T - THERMOSTAT

ADD THE OVERALL WIDTH (IN INCHES) OF THE VENTILATOR AFTER MODEL DESIGNATION

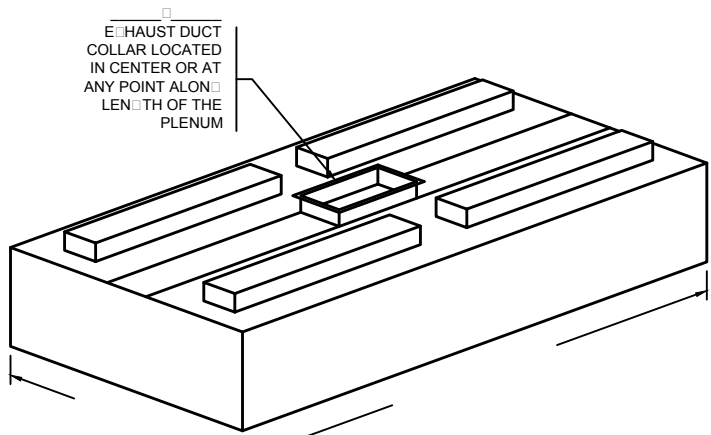

STANDARD LIGHT FIXTURES
 100 WATT INCANDESCENT
 RECESSED INCANDESCENT
 RECESSED FLUORESCENT (IF RECESSED FLUORESCENT SPECIFY SIZE)

CONSULT FACTORY FOR NON-STANDARD HEIGHTS
 12" MIN. FRONT AND REAR OVERHANG

6" MIN. SIDE OVERHANG (12" MIN. SIDE OVERHANG FOR CHARBROILER)

ITEM # _____
 EST. WEIGHT _____
 LENGTH _____
 WIDTH _____
 HEIGHT _____
 EXHAUST-CFM _____
 DUCT SIZE _____
 S.P. _____

DIMENSION VARIES WITH DEPTH OF THE EQUIPMENT AND REQUIRED OVERHANG

14'-0" MAX. UNIT LENGTH. FOR GREATER LENGTH, JOIN TWO OR MORE UNITS TOGETHER. ALLOW 6" MIN. OVERHANG AT EACH END. IF CHARBROILER IS AT END, OVERHANG 12"

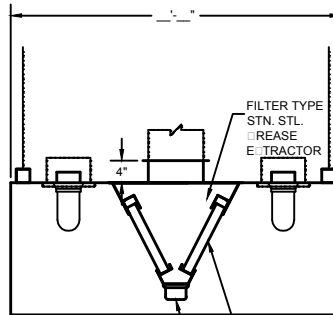

BAFFLE TYPE REASE FILTERS
 UL CLASSIFIED (BOTH SIDES)
 REMOVABLE
 STN./STL.
 REASE CUP

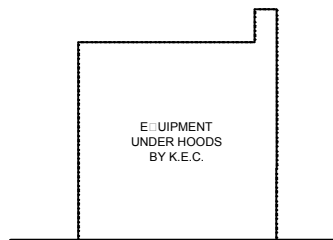

DRAWINGS NOT TO SCALE

ENGINEERING DATA

Ventilator Length

Maximum ventilator length in a single section is 14'-0". For lengths greater than 14'-0", join two or more sections. Verify access conditions into building and kitchen space prior to length selection.

Ventilator Hanging Weight

Wt./lineal ft.	Lbs.	90
----------------	------	----

NOTE: Refer to **CADDY AirSystems**

Master Engineering Data Sheet in engineering data section for determining light, medium, and heavy duty cooking equipment, C.F.M. requirements (exhaust and supply), duct collar sizes and static pressure requirements.

Electrical Requirements

Light fixtures to be powered by a 120/1/60 circuit.

Mechanical Requirements

The volume of exhaust required is a function of the type of cooking equipment served by the ventilator, and the type and volume of product cooked. Refer to the **CADDY AirSystems**

Master Engineering Data Chart to determine exhaust volume, duct collar sizes, static pressure drop.



CADDY Air Systems

Model PB-C-II-PA Dry Filter Ventilator

ITEM NO:

PROJECT:

LOCATION:

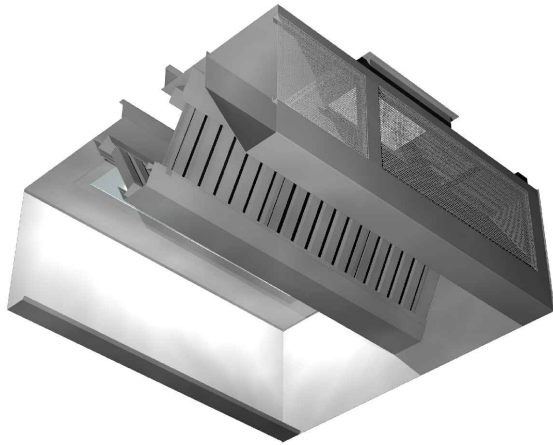
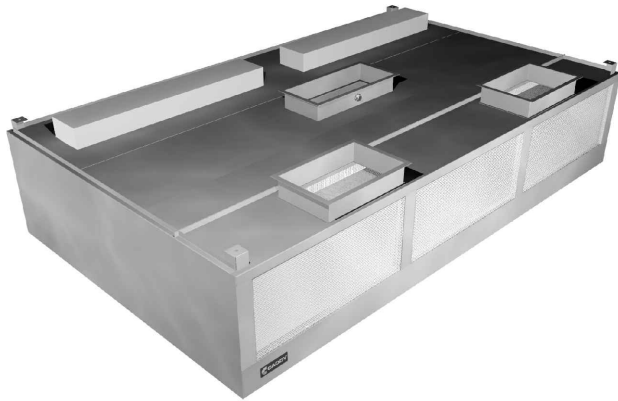

General Specifications

Furnish CADDY **AirSystems** Exhaust Ventilator Model **PB-C-II-PA** as shown on the plans and as described in the following specifications.

General

Exhaust ventilator shall be constructed of 18 gauge type 300 series stainless steel. All exposed surfaces to have a #4 finish. Construction to meet all requirements of NFPA 96 and NSF Standard No. 2. To include necessary hanger brackets at front and rear suspending from building overhead structure.

Description

The CADDY **AirSystems** Model "PB" Series ventilator is a dry filter type and is ETL listed under the standards set forth in UL 710 "Exhaust Hoods for Commercial Cooking Equipment". This ventilator is 90% grease extraction efficient when operated and maintained in accordance with design specifications.

Filters to be UL Classified stainless steel baffle type. This high efficiency is accomplished by utilizing removable stainless steel baffle filters containing a series of horizontal, self-draining baffles. As the air is drawn around the baffles, the grease, dust and lint particles are slung from the airstream by centrifugal force. As the liquefied grease is extracted, it is drained off via a trough into grease collection containers at each end of the ventilator. At the end of the cooking day or at scheduled intervals, the filters are removed for cleaning without having to climb up or onto the cooking equipment. Once removed, the filters can be washed either in a dishwasher or soaked and rinsed off in a pot sink. Each filter is a maximum of 19-1/2" long. Ventilator can also be equipped with an optional fusible link or thermostatically activated fire damper assembly.

Make-Up Air (Front Face Discharge)

Ventilator shall have 40% open stainless steel perforated screens along front face for discharge of tempered make-up air. Supply volume is 80% or designed to the desired air balance.

Application

Island style cooking applications for use over all types of cooking equipment where integral make-up air is required.

Light Fixtures

All light fixtures shall be pre-wired to a single connection point. Ventilators built in multiple sections to be furnished with junction boxes for ease of field connection by the electrical trades. Light bulbs furnished and installed by the Kitchen Equipment Contractor.

Exhaust Fans

Exhaust fans are to be provided and installed by others in compliance with local codes. **Fans should be induced draft, squirrel cage design, equipped with backward inclined blades.**

Fire Protection

NFPA 96 and local codes require a fire extinguishing system for protection of the duct collar and plenum of all ventilators, as well as for the protection of various cooking appliances such as deep fat fryers, griddles, ranges, and broilers, which may be a source of ignition of grease. Consult factory and local fire officials for exact requirements. UL Listed fire protection systems may be pre-piped by Caddy at the time of manufacture, assuring concealment of piping and detectors.

Approvals

Ventilator shall be ETL Listed, listed by NSF and be in accordance with all of the recommendations set forth by NFPA 96. All ventilators must meet all applicable codes.

 **CADDY CORPORATION**
509 Sharptown Road P.O. Box 345
Bridgeport, NJ 08014-0345
Tel: 856-467-4222 Fax: 856-467-5511
internet: www.caddycorp.com



MODEL:

PB-C-II-PA---

ADD THE OVERALL LENGTH (IN INCHES) OF THE VENTILATOR AFTER MODEL DESIGNATION

DAMPER TYPE
ND - NO DAMPER
FL - FUSIBLE LINK
T - THERMOSTAT

ADD THE OVERALL WIDTH (IN INCHES) OF THE VENTILATOR AFTER MODEL DESIGNATION

STANDARD LIGHT FIXTURES
() 100 WATT INCANDESCENT
() RECESSED INCANDESCENT
() RECESSED FLUORESCENT
(IF RECESSED FLUORESCENT SPECIFY SIZE)

CONSULT FACTORY FOR NON-STANDARD HEIGHTS

12" MIN. FRONT AND REAR OVERHANG

6" MIN. SIDE OVERHANG
(12" MIN. SIDE OVERHANG FOR CHARBROILER)

ITEM # _____
EST. WEIGHT _____
LENGTH _____
WIDTH _____
HEIGHT _____
EXHAUST-CFM _____
DUCT SIZE _____
S.P. _____

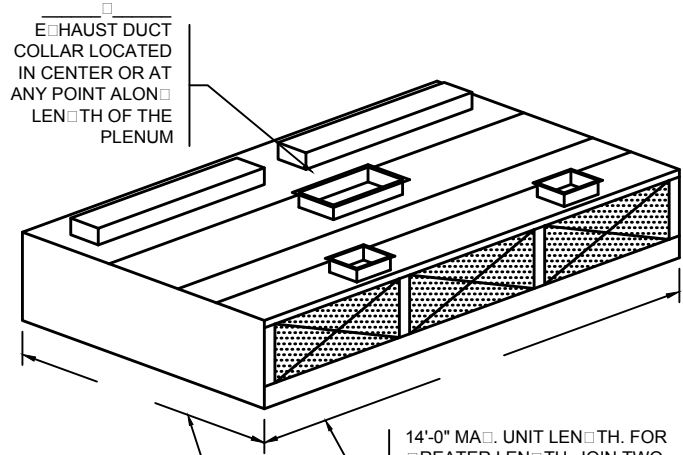

EXHAUST DUCT COLLAR LOCATED IN CENTER OR AT ANY POINT ALONG LENGTH OF THE PLENUM

14'-0" MAX. UNIT LENGTH. FOR GREATER LENGTH, JOIN TWO OR MORE UNITS TOGETHER. ALLOW 6" MIN. OVERHANG AT EACH END. IF CHARBROILER IS AT END, OVERHANG 12"

DIMENSION VARIES WITH DEPTH OF THE EQUIPMENT AND REQUIRED OVERHANG

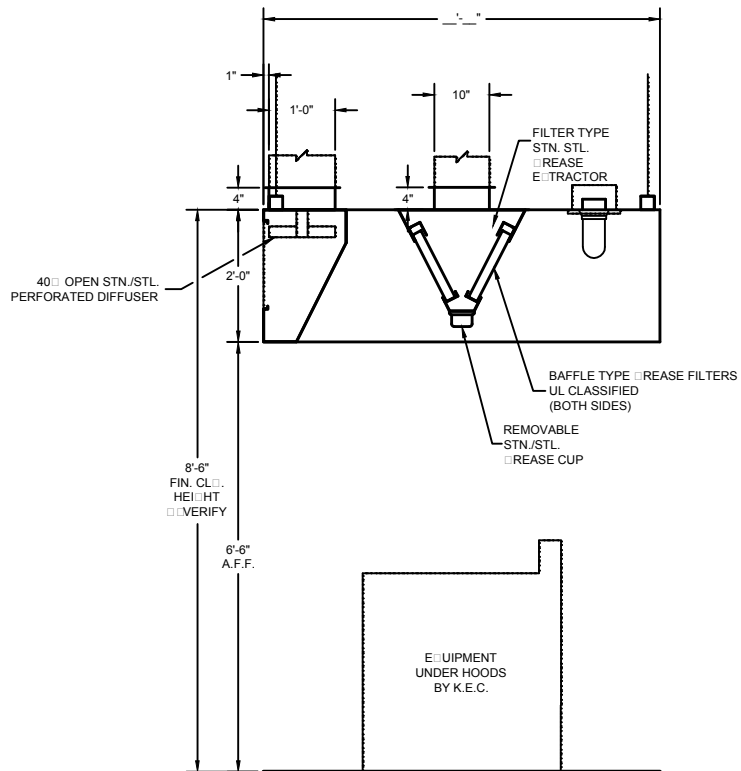

40# OPEN STN/STL PERFORATED DIFFUSER

FILTER TYPE
STN. STL.
REASE
EXTRACTOR

BAFFLE TYPE # REASE FILTERS
UL CLASSIFIED
(BOTH SIDES)

REMOVABLE STN/STL # REASE CUP

8'-6" FIN. CL. HEIGHT
VERIFY

6'-6" A.F.F.

EQUIPMENT UNDER HOODS BY K.E.C.

DRAWINGS NOT TO SCALE

ENGINEERING DATA

Ventilator Length

Maximum ventilator length in a single section is 14'-0". For lengths greater than 14'-0", join two or more sections. Verify access conditions into building and kitchen space prior to length selection.

Ventilator Hanging Weight

Wt./lineal ft. Lbs. 105

NOTE: Refer to CADDY AirSystems

Master Engineering Data Sheet in engineering data section for determining light, medium, and heavy duty cooking equipment, C.F.M. requirements (exhaust and supply), duct collar sizes and static pressure requirements.

Electrical Requirements

Light fixtures to be powered by a 120/1/60 circuit.

Mechanical Requirements

The volume of exhaust required is a function of the type of cooking equipment served by the ventilator, and the type and volume of product cooked. Refer to the CADDY AirSystems

Master Engineering Data Chart to determine exhaust volume, duct collar sizes, static pressure drop.



CADDY Air Systems

ITEM NO:

Model PB-C-II

Dry Filter Ventilator - With Ceiling Supply Plenum

PROJECT:

LOCATION:

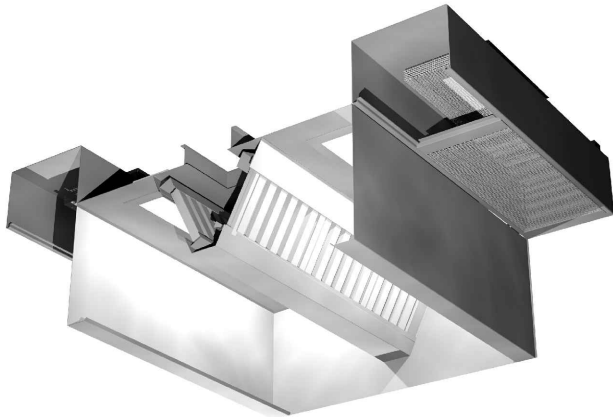
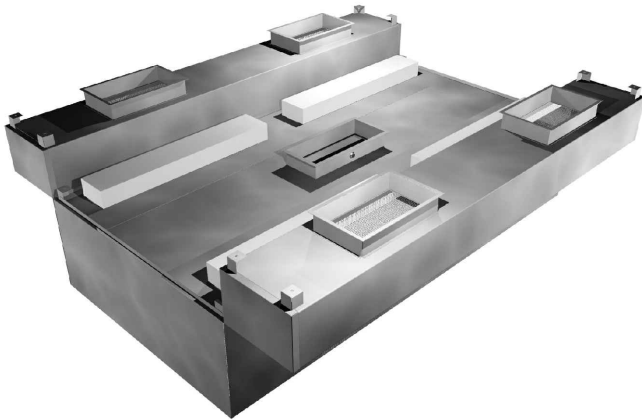

General Specifications

Furnish CADDY *AirSystems* Exhaust Ventilator Model **PB-C-II** as shown on the plans and as described in the following specifications.

General

Exhaust ventilator shall be constructed of 18 gauge type 300 series stainless steel. All exposed surfaces to have a #4 finish. Construction to meet all requirements of NFPA 96 and NSF Standard No. 2. To include necessary hanger brackets at front and rear suspending from building overhead structure.

Description

The CADDY *AirSystems* Model "PB" Series ventilator is a dry filter type and is ETL listed under the standards set forth in UL 710 "Exhaust Hoods for Commercial Cooking Equipment". This ventilator is 90% grease extraction efficient when operated and maintained in accordance with design specifications.

Filters to be UL Classified stainless steel baffle type. This high efficiency is accomplished by utilizing removable stainless steel baffle filters containing a series of horizontal, self-draining baffles. As the air is drawn around the baffles, the grease, dust and lint particles are slung from the airstream by centrifugal force. As the liquefied grease is extracted, it is drained off via a trough into grease collection containers at each end of the ventilator. At the end of the cooking day or at scheduled intervals, the filters are removed for cleaning without having to climb up or onto the cooking equipment. Once removed, the filters can be washed either in a dishwasher or soaked and rinsed off in a pot sink. Each filter is a maximum of 19-1/2" long. Ventilator can also be equipped with an optional fusible link or thermostatically activated fire damper assembly.

Make-Up Air (Perimeter Down Discharge)

Ventilator shall have air registers along perimeter for down discharge of tempered make-up. Supply volume is 80% or designed to the desired air balance.

Application

Island style cooking applications for use over all types of cooking equipment where integral make-up air is required.

Light Fixtures

All light fixtures shall be pre-wired to a single connection point. Ventilators built in multiple sections to be furnished with junction boxes for ease of field connection by the electrical trades. Light bulbs furnished and installed by the Kitchen Equipment Contractor.

Exhaust Fans

Exhaust fans are to be provided and installed by others in compliance with local codes. **Fans should be induced draft, squirrel cage design, equipped with backward inclined blades.**

Fire Protection

NFPA 96 and local codes require a fire extinguishing system for protection of the duct collar and plenum of all ventilators, as well as for the protection of various cooking appliances such as deep fat fryers, griddles, ranges, and broilers, which may be a source of ignition of grease. Consult factory and local fire officials for exact requirements. UL Listed fire protection systems may be pre-piped by Caddy at the time of manufacture, assuring concealment of piping and detectors.

Approvals

Ventilator shall be ETL Listed, listed by NSF and be in accordance with all of the recommendations set forth by NFPA 96. All ventilators must meet all applicable codes.

 **CADDY CORPORATION**
509 Sharptown Road P.O. Box 345
Bridgeport, NJ 08014-0345
Tel: 856-467-4222 Fax: 856-467-5511
internet: www.caddycorp.com



MODEL:

PB-C-II- - -

ADD THE OVERALL LENGTH (IN INCHES) OF THE VENTILATOR AFTER MODEL DESIGNATION

DAMPER TYPE
ND - NO DAMPER
FL - FUSIBLE LINK
T - THERMOSTAT

ADD THE OVERALL WIDTH (IN INCHES) OF THE VENTILATOR AFTER MODEL DESIGNATION

EXHAUST DUCT COLLAR LOCATED IN CENTER OR AT ANY POINT ALONG LENGTH OF THE PLENUM

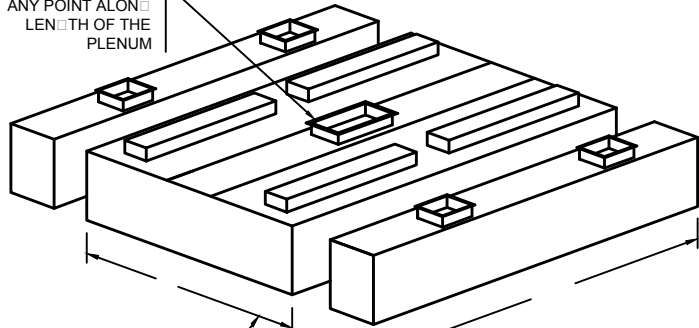

DIMENSION VARIES WITH DEPTH OF THE EQUIPMENT AND REQUIRED OVERHANG

14'-0" MAX. UNIT LENGTH. FOR GREATER LENGTH, JOIN TWO OR MORE UNITS TOGETHER. ALLOW 6" MIN. OVERHANG AT EACH END. IF CHARBROILER IS AT END, OVERHANG 12"

STANDARD LIGHT FIXTURES
() 100 WATT INCANDESCENT
() RECESSED INCANDESCENT
() RECESSED FLUORESCENT
(IF RECESSED FLUORESCENT SPECIFY SIZE)

CONSULT FACTORY FOR NON-STANDARD HEIGHTS

22" MIN. FRONT OVERHANG

6" MIN. SIDE OVERHANG
(12" MIN. SIDE OVERHANG FOR CHARBROILER)

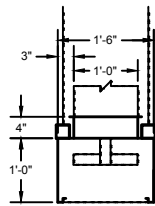

1'-6" MIN.
4'-0" MAX.

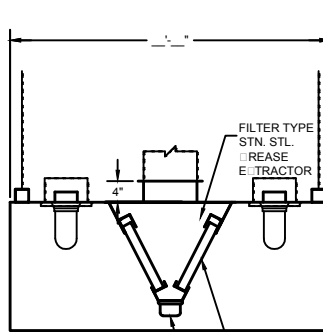

40" OPEN STN./STL. PERFORATED DIFFUSER

BAFFLE TYPE RESEAL FILTERS
UL CLASSIFIED
(BOTH SIDES)
REMOVABLE
STN./STL.
RESEAL CUP

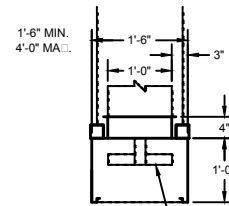

1'-6" MIN.
4'-0" MAX.

ITEM #	_____
EST. WEIGHT	_____
LENGTH	_____
WIDTH	_____
HEIGHT	_____
EXHAUST-CFM	_____
DUCT SIZE	_____
S.P.	_____

EQUIPMENT UNDER HOODS BY K.E.C.

DRAWINGS NOT TO SCALE

ENGINEERING DATA

Ventilator Length

Maximum ventilator length in a single section is 14'-0". For lengths greater than 14'-0", join two or more sections. Verify access conditions into building and kitchen space prior to length selection.

Ventilator Hanging Weight

Wt./lineal ft.	Lbs.	90
----------------	------	----

NOTE: Refer to CADDY AirSystems

Master Engineering Data Sheet in engineering data section for determining light, medium, and heavy duty cooking equipment, C.F.M. requirements (exhaust and supply), duct collar sizes and static pressure requirements.

Electrical Requirements

Light fixtures to be powered by a 120/1/60 circuit.

Mechanical Requirements

The volume of exhaust required is a function of the type of cooking equipment served by the ventilator, and the type and volume of product cooked. Refer to the **CADDY AirSystems**

Master Engineering Data Chart to determine exhaust volume, duct collar sizes, static pressure drop.



CADDY Air Systems

ITEM NO:

Model PB-BK-I Dry Filter Ventilator

PROJECT:

LOCATION:



General Specifications

Furnish CADDY *AirSystems* Exhaust Ventilator Model **PB-BK-W** as shown on the plans and as described in the following specifications.

General

Exhaust ventilator shall be constructed of 18 gauge type 300 series stainless steel. All exposed surfaces to have a \square 4 finish. Construction to meet all requirements of NFPA 96 and NSF Standard No. 2. To include necessary hanger brackets at front and rear suspending from building overhead structure.

Description

The CADDY *AirSystems* Model "PB" Series ventilator is a dry filter type and is ETL listed under the standards set forth in UL 710 "Exhaust Hoods for Commercial Cooking Equipment". This ventilator is 90 \square grease extraction efficient when operated and maintained in accordance with design specifications. Filters to be UL Classified stainless steel baffle type. This high efficiency is accomplished by utilizing removable stainless steel baffle filters containing a series of horizontal, self-draining baffles. As the air is drawn around the baffles, the grease, dust and lint particles are slung from the airstream by centrifugal force. As the liquefied grease is extracted, it is drained off via a trough into grease collection containers at each end of the ventilator. At the end of the cooking day or at scheduled intervals, the filters are removed for cleaning without having to climb up or onto the cooking equipment. Once removed, the filters can be washed either in a dishwasher or soaked and rinsed off in a pot sink. Each filter is a maximum of 19-1/2" long. Ventilator can also be equipped with an optional fusible link or thermostatically activated fire damper assembly.

Application

Eyebrow style for direct mounting to roast, bake, reel and pizza ovens.

Exhaust Fans

Exhaust fans are to be provided and installed by others in compliance with local codes. **Fans should be induced draft, squirrel cage design, equipped with backward inclined blades.**

Fire Protection

NFPA 96 and local codes require a fire extinguishing system for protection of the duct collar and plenum of all ventilators, as well as for the protection of various cooking appliances such as deep fat fryers, griddles, ranges, and broilers, which may be a source of ignition of grease. Consult factory and local fire officials for exact requirements. UL Listed fire protection systems may be pre-piped by Caddy at the time of manufacture, assuring concealment of piping and detectors.

Approvals

Ventilator shall be ETL Listed, listed by NSF and be in accordance with all of the recommendations set forth by NFPA 96. All ventilators must meet all applicable codes.

 **CADDY CORPORATION**
509 Sharptown Road P.O. Box 345
Bridgeport, NJ 08014-0345
Tel: 856-467-4222 Fax: 856-467-5511
internet: www.caddycorp.com



MODEL:

PB-BK-I - [] - [] - []

ADD THE OVERALL LENGTH (IN INCHES) OF THE VENTILATOR AFTER MODEL DESIGNATION

DAMPER TYPE
ND - NO DAMPER
FL - FUSIBLE LINK
T - THERMOSTAT

ADD THE OVERALL WIDTH (IN INCHES) OF THE VENTILATOR AFTER MODEL DESIGNATION

EXHAUST DUCT COLLAR LOCATED IN CENTER OR AT ANY POINT ALONG LENGTH OF THE PLENUM

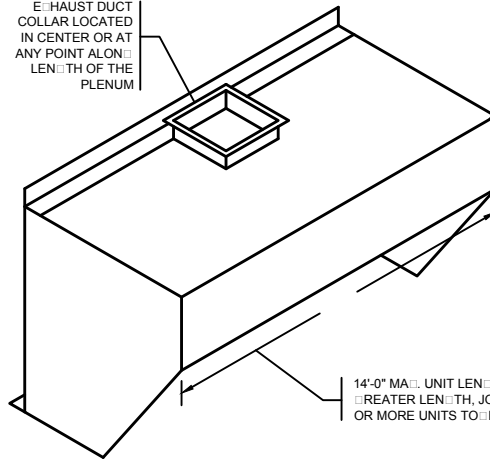

14'-0" MAX. UNIT LENGTH. FOR GREATER LENGTH, JOIN TWO OR MORE UNITS TOGETHER.

STANDARD LIGHT FIXTURES
() 100 WATT INCANDESCENT
() RECESSED INCANDESCENT
() RECESSED FLUORESCENT
(IF RECESSED FLUORESCENT SPECIFY SIZE)

CONSULT FACTORY FOR NON-STANDARD HEIGHTS

- ITEM # _____
- EST. WEIGHT _____
- LENGTH _____
- WIDTH _____
- HEIGHT _____
- EXHAUST-CFM _____
- DUCT SIZE _____
- S.P. _____

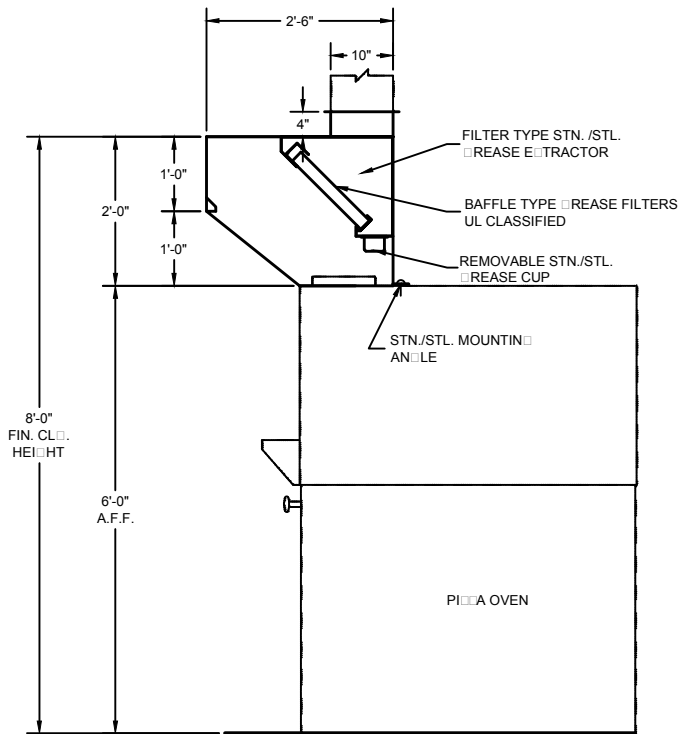

DRAWINGS NOT TO SCALE

ENGINEERING DATA

Ventilator Length

Maximum ventilator length in a single section is 14'-0". For lengths greater than 14'-0", join two or more sections. Verify access conditions into building and kitchen space prior to length selection.

Ventilator Hanging Weight

Wt./lineal ft. Lbs. 65

NOTE: Refer to **CADDY AirSystems**

Master Engineering Data Sheet in engineering data section for determining light, medium, and heavy duty cooking equipment, C.F.M. requirements (exhaust and supply), duct collar sizes and static pressure requirements.

Electrical Requirements

Light fixtures to be powered by a 120/1/60 circuit.

Mechanical Requirements

The volume of exhaust required is a function of the type of cooking equipment served by the ventilator, and the type and volume of product cooked. Refer to the **CADDY AirSystems**

Master Engineering Data Chart to determine exhaust volume, duct collar sizes, static pressure drop.



CADDY Air Systems

ITEM NO:

Model PB-BK-W Dry Filter Ventilator

PROJECT:

LOCATION:



General Specifications

Furnish CADDY *AirSystems* Exhaust Ventilator Model **PB-BK-W** as shown on the plans and as described in the following specifications.

General

Exhaust ventilator shall be constructed of 18 gauge type 300 series stainless steel. All exposed surfaces to have a \square 4 finish. Construction to meet all requirements of NFPA 96 and NSF Standard No. 2. To include necessary hanger brackets at front and rear suspending from building overhead structure.

Description

The CADDY *AirSystems* Model "PB" Series ventilator is a dry filter type and is ETL listed under the standards set forth in UL 710 "Exhaust Hoods for Commercial Cooking Equipment". This ventilator is 90 \square grease extraction efficient when operated and maintained in accordance with design specifications. Filters to be UL Classified stainless steel baffle type. This high efficiency is accomplished by utilizing removable stainless steel baffle filters containing a series of horizontal, self-draining baffles. As the air is drawn around the baffles, the grease, dust and lint particles are slung from the airstream by centrifugal force. As the liquefied grease is extracted, it is drained off via a trough into grease collection containers at each end of the ventilator. At the end of the cooking day or at scheduled intervals, the filters are removed for cleaning without having to climb up or onto the cooking equipment. Once removed, the filters can be washed either in a dishwasher or soaked and rinsed off in a pot sink. Each filter is a maximum of 19-1/2" long. Ventilator can also be equipped with an optional fusible link or thermostatically activated fire damper assembly.

Application

Backshelf style for use over all types of cooking equipment 36" high or less. The shelf of the ventilator shall serve as a plate or pan storage area.

Exhaust Fans

Exhaust fans are to be provided and installed by others in compliance with local codes. **Fans should be induced draft, squirrel cage design, equipped with backward inclined blades.**

Fire Protection

NFPA 96 and local codes require a fire extinguishing system for protection of the duct collar and plenum of all ventilators, as well as for the protection of various cooking appliances such as deep fat fryers, griddles, ranges, and broilers, which may be a source of ignition of grease. Consult factory and local fire officials for exact requirements. UL Listed fire protection systems may be pre-piped by Caddy at the time of manufacture, assuring concealment of piping and detectors.

Approvals

Ventilator shall be ETL Listed, listed by NSF and be in accordance with all of the recommendations set forth by NFPA 96. All ventilators must meet all applicable codes.

 **CADDY CORPORATION**
509 Sharptown Road P.O. Box 345
Bridgeport, NJ 08014-0345
Tel: 856-467-4222 Fax: 856-467-5511
internet: www.caddycorp.com



MODEL:

PB-BK-W- - -

ADD THE OVERALL LENGTH (IN INCHES) OF THE VENTILATOR AFTER MODEL DESIGNATION

DAMPER TYPE
 ND - NO DAMPER
 FL - FUSIBLE LINK
 T - THERMOSTAT

ADD THE OVERALL WIDTH (IN INCHES) OF THE VENTILATOR AFTER MODEL DESIGNATION

STANDARD LIGHT FIXTURES
 100 WATT INCANDESCENT
 RECESSED INCANDESCENT
 RECESSED FLUORESCENT
 (IF RECESSED FLUORESCENT SPECIFY SIZE)

CONSULT FACTORY FOR NON-STANDARD HEIGHTS

ITEM # _____
 EST. WEIGHT _____
 LENGTH _____
 WIDTH _____
 HEIGHT _____
 EXHAUST-CFM _____
 DUCT SIZE _____
 S.P. _____

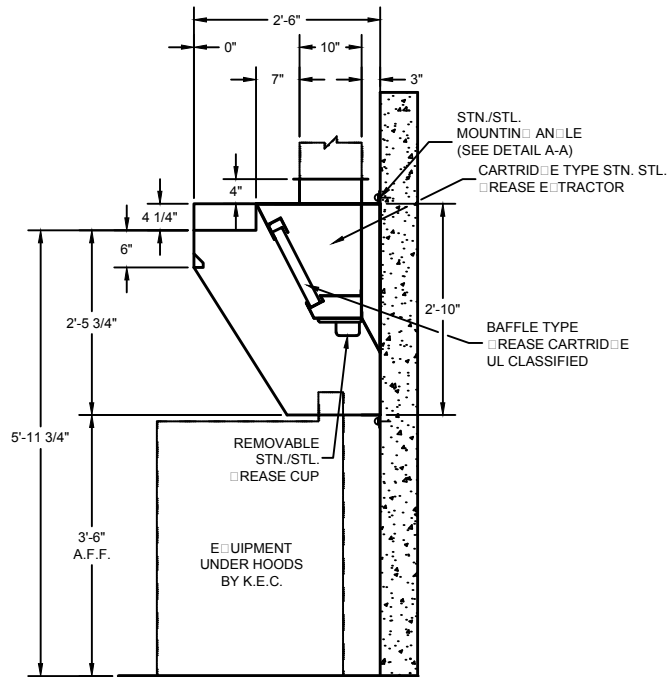
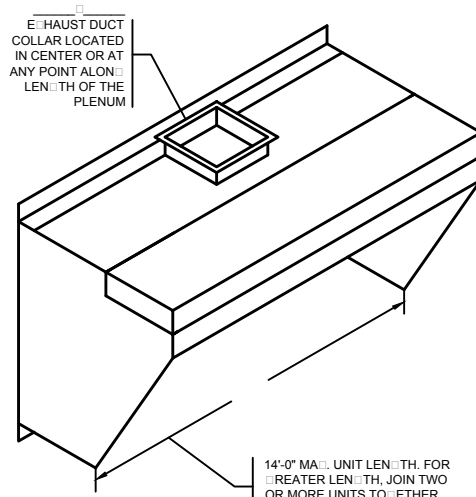

DRAWINGS NOT TO SCALE

ENGINEERING DATA

Ventilator Length

Maximum ventilator length in a single section is 14'-0". For lengths greater than 14'-0", join two or more sections. Verify access conditions into building and kitchen space prior to length selection.

Ventilator Hanging Weight

Wt./lineal ft. Lbs. 65

NOTE: Refer to **CADDY AirSystems**

Master Engineering Data Sheet in engineering data section for determining light, medium, and heavy duty cooking equipment, C.F.M. requirements (exhaust and supply), duct collar sizes and static pressure requirements.

Electrical Requirements

Light fixtures to be powered by a 120/1/60 circuit.

Mechanical Requirements

The volume of exhaust required is a function of the type of cooking equipment served by the ventilator, and the type and volume of product cooked. Refer to the **CADDY AirSystems**

Master Engineering Data Chart to determine exhaust volume, duct collar sizes, static pressure drop.



CADDY Air Systems

Options & Accessories

Lighting Options:

Multiple lighting options are available:

Dome Lights: incandescent or LED



Recessed 12" x 12" incandescent



Recessed 24", 36" or 48" fluorescent or LED

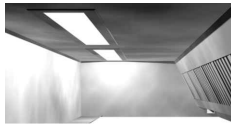

Recessed 10" x 10" LED fixtures



All fixtures are vapor proof and UL Approved.

Exhaust Collars:

- Factory Mounted: Collars are fully welded to the exhaust plenum and include a 1 inch flange.
- Shipped Loose: exhaust openings can be cut on site when exact locations are not known.
- Shape: Rectangular or Round to accommodate ductwork.
- Location: Top, back, or side.

Supply Collars:

- Shipped Loose
- Shape: Rectangular or Round
- Number: Variable

Tapered Hood: Available to accommodate low ceiling applications.



Enclosure Panels:



Stainless Steel Wall Flashing:



 **CADDY CORPORATION**
509 Sharptown Road P.O. Box 345
Bridgeport, NJ 08014-0345
Tel: 856-467-4222 Fax: 856-467-5511
internet: www.caddycorp.com



CADDY CORPORATION

Food Service Equipment

Air Systems

Commercial Kitchen Exhaust Systems

Model SHBC

Baffle Cartridge Style

CADDY Air Systems

Model SHBC-C-W

Baffle Cartridge Ventilator

ITEM NO:

PROJECT:

LOCATION:

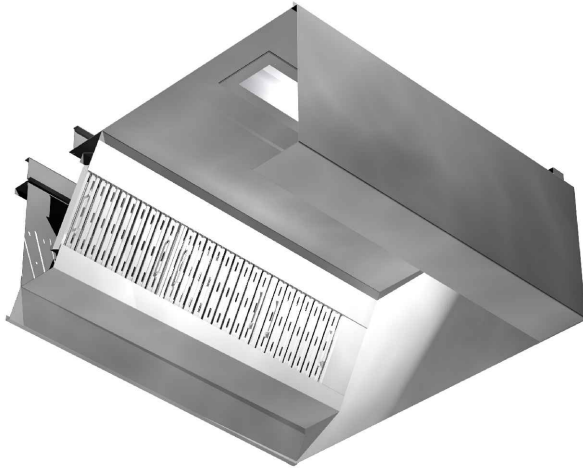

General Specifications

Furnish CADDY Air Systems Exhaust Ventilator Model **SHBC-C-W** as shown on the plans and as described in the following specifications.

General

Exhaust ventilator shall be constructed of 18 gauge type 300 series stainless steel. All exposed surfaces to have a #4 finish. Construction to meet all requirements of NFPA 96 and NSF Standard No. 2. To include necessary hanger brackets at front and rear suspending from building overhead structure.

Description

The CADDY Air Systems Model "SHBC" Series ventilator is a dry baffle cartridge type and is ETL listed under the standards as set forth in UL710 "Exhaust Hoods for Commercial Cooking Equipment." This ventilator is 95% grease extraction efficient when operated and maintained in accordance with design specifications. This high efficiency is accomplished by utilizing removable stainless steel baffle cartridges containing a series of horizontal, self-draining baffles. As the air is drawn around the baffles, the grease, dust and lint particles are slung from the air stream by centrifugal force. As the liquefied grease is extracted, it is drained off via a trough into grease collection containers at each end of the ventilator. At the end of the cooking day or at scheduled intervals, the cartridges are removed for cleaning without having to climb up or onto the cooking equipment with the use of a baffle cartridge removal tool. Once removed, the baffle cartridges can be washed in either the dishwasher or soaked and rinsed off in a pot sink. Each baffle cartridge is a maximum of 19-1/2" long. Ventilator can also be equipped with an optional fusible link or thermostatically activated fire damper assembly.

Application

Wall mounted exhaust only canopy style for use over all types of cooking equipment.

Light Fixtures

All light fixtures shall be pre-wired to a single connection point. Ventilators built in multiple sections to be furnished with junction boxes for ease of field connection by the electrical trades. Light bulbs furnished and installed by the Kitchen Equipment Contractor.

Exhaust Fans

Exhaust fans are to be provided and installed by others in compliance with local codes. **Fans should be induced draft, squirrel cage design, equipped with backward inclined blades.**

Fire Protection

NFPA 96 and local codes require a fire extinguishing system for protection of the duct collar and plenum of all ventilators, as well as for the protection of various cooking appliances such as deep fat fryers, griddles, ranges, and broilers, which may be a source of ignition of grease. Consult factory and local fire officials for exact requirements. UL Listed fire protection systems may be pre-piped by Caddy at the time of manufacture, assuring concealment of piping and detectors.

Approvals

Ventilator shall be ETL Listed, listed by NSF and be in accordance with all of the recommendations set forth by NFPA 96. Filters tested to ASTM Standard F2519-05 by independent third party. All ventilators must meet all applicable codes.

CADDY CORPORATION
509 Sharptown Road P.O. Box 345
Bridgeport, NJ 08014-0345
Tel: 856-467-4222 Fax: 856-467-5511
internet: www.caddycorp.com



MODEL:

SHBC-C-W - [] - [] - []

ADD THE OVERALL LENGTH (IN INCHES) OF THE VENTILATOR AFTER MODEL DESIGNATION

DAMPER TYPE
ND - NO DAMPER
FL - FUSIBLE LINK
T - THERMOSTAT

ADD THE OVERALL WIDTH (IN INCHES) OF THE VENTILATOR AFTER MODEL DESIGNATION

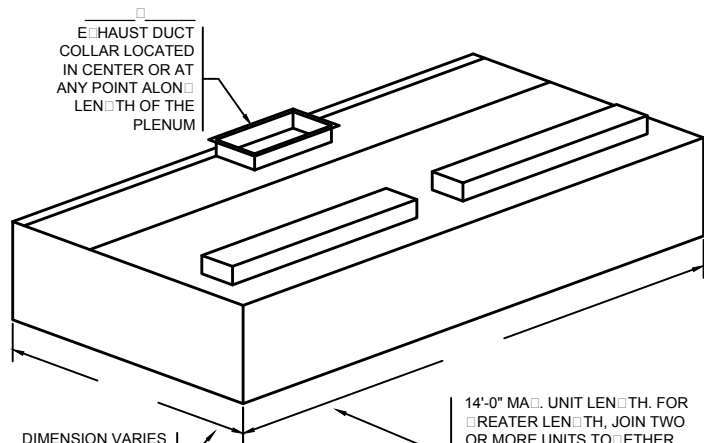

EXHAUST DUCT COLLAR LOCATED IN CENTER OR AT ANY POINT ALONG LENGTH OF THE PLENUM

DIMENSION VARIES WITH DEPTH OF THE EQUIPMENT AND REQUIRED OVERHANG

14'-0" MAX. UNIT LENGTH. FOR GREATER LENGTH, JOIN TWO OR MORE UNITS TOGETHER. ALLOW 6" MIN. OVERHANG AT EACH END. IF CHARBROILER IS AT END, OVERHANG 12"

STANDARD LIGHT FIXTURES
() 100 WATT INCANDESCENT
() RECESSED INCANDESCENT
() RECESSED FLUORESCENT
(IF RECESSED FLUORESCENT SPECIFY SIZE)

CONSULT FACTORY FOR NON-STANDARD HEIGHTS
12" MIN. FRONT OVERHANG
6" MIN. SIDE OVERHANG (12" MIN. SIDE OVERHANG FOR CHARBROILER)

ITEM # _____
EST. WEIGHT _____
LENGTH _____
WIDTH _____
HEIGHT _____
EXHAUST-CFM _____
DUCT SIZE _____
S.P. _____

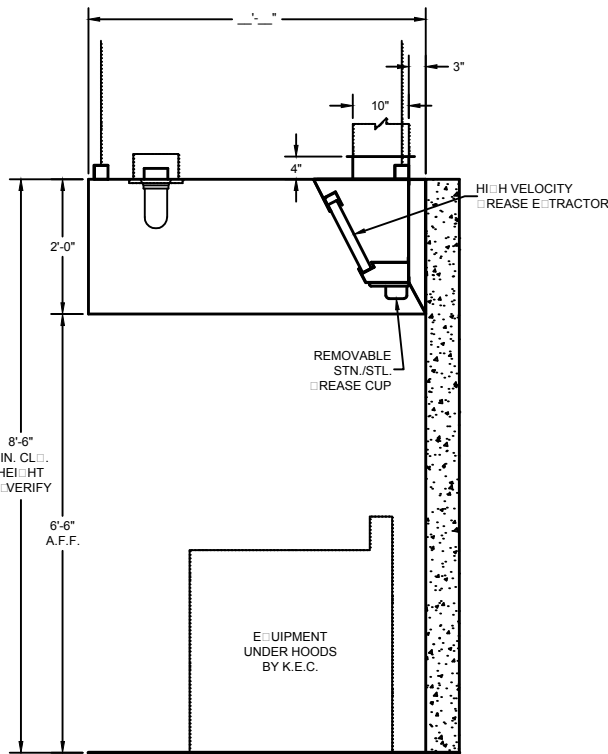

SECTION

DRAWINGS NOT TO SCALE

ENGINEERING DATA

Ventilator Length

Maximum ventilator length in a single section is 14'-0". For lengths greater than 14'-0", join two or more sections. Verify access conditions into building and kitchen space prior to length selection.

Ventilator Hanging Weight

Wt./lineal ft. Lbs. 75

NOTE: Refer to CADDY AirSystems

Master Engineering Data Sheet in engineering data section for determining light, medium, and heavy duty cooking equipment, C.F.M. requirements (exhaust and supply), duct collar sizes and static pressure requirements.

Electrical Requirements

Light fixtures to be powered by a 120/1/60 circuit.

Mechanical Requirements

The volume of exhaust required is a function of the type of cooking equipment served by the ventilator, and the type and volume of product cooked. Refer to the CADDY AirSystems Master Engineering Data Chart to determine exhaust volume, duct collar sizes, static pressure drop.



CADDY Air Systems

Model SHBC-C-W-PA Baffle Cartridge Ventilator

ITEM NO:

PROJECT:

LOCATION:

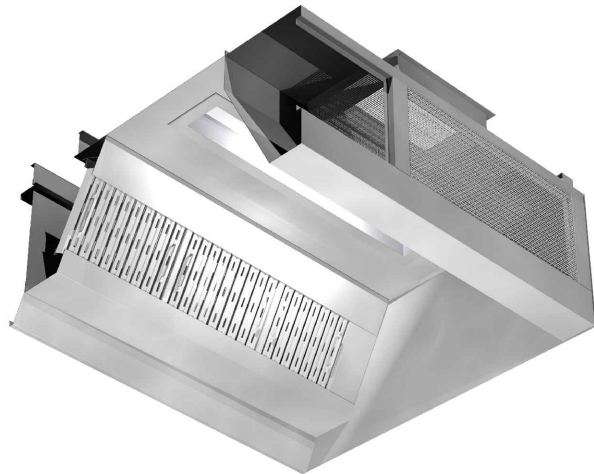
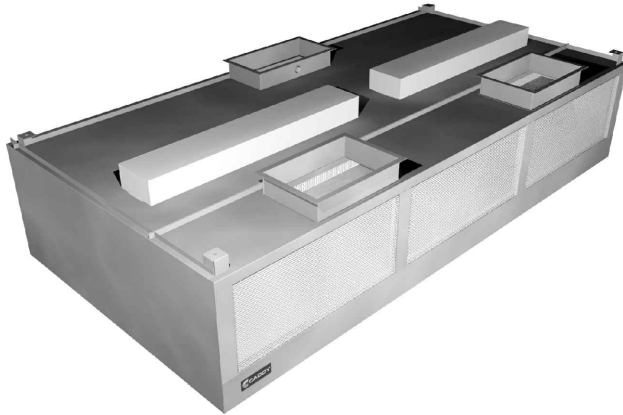

General Specifications

Furnish CADDY Air Systems Exhaust Ventilator Model SHBC-C-W-PA as shown on the plans and as described in the following specifications.

General

Exhaust ventilator shall be constructed of 18 gauge type 300 series stainless steel. All exposed surfaces to have a #4 finish. Construction to meet all requirements of NFPA 96 and NSF Standard No. 2. To include necessary hanger brackets at front and rear suspending from building overhead structure.

Description

The CADDY Air Systems Model "SHBC" Series ventilator is a dry baffle cartridge type and is ETL listed under the standards as set forth in UL710 "Exhaust Hoods for Commercial Cooking Equipment."

This high efficiency is accomplished by utilizing removable stainless steel baffle cartridges containing a series of horizontal, self-draining baffles. As the air is drawn around the baffles, the grease, dust and lint particles are slung from the air stream by centrifugal force. As the liquefied grease is extracted, it is drained off via a trough into grease collection containers at each end of the ventilator. At the end of the cooking day or at scheduled intervals, the cartridges are removed for cleaning without having to climb up or onto the cooking equipment with the use of a baffle cartridge removal tool. Once removed, the baffle cartridges can be washed in either the dishwasher or soaked and rinsed off in a pot sink. Each baffle cartridge is a maximum of 19-1/2" long. Ventilator can also be equipped with an optional fusible link or thermostatically activated fire damper assembly.

Make-Up Air (Front Face Discharge)

Ventilator shall have 40% open stainless steel perforated screens along front face for discharge of tempered make-up air. Supply volume is 80% or designed to the desired air balance.

Application

Wall mounted exhaust only canopy style for use over all types of cooking equipment.

Light Fixtures

All light fixtures shall be pre-wired to a single connection point. Ventilators built in multiple sections to be furnished with junction boxes for ease of field connection by the electrical trades. Light bulbs furnished and installed by the Kitchen Equipment Contractor.

Exhaust Fans

Exhaust fans are to be provided and installed by others in compliance with local codes. **Fans should be induced draft, squirrel cage design, equipped with backward inclined blades.**

Fire Protection

NFPA 96 and local codes require a fire extinguishing system for protection of the duct collar and plenum of all ventilators, as well as for the protection of various cooking appliances such as deep fat fryers, griddles, ranges, and broilers, which may be a source of ignition of grease. Consult factory and local fire officials for exact requirements. UL Listed fire protection systems may be pre-piped by Caddy at the time of manufacture, assuring concealment of piping and detectors.

Approvals

Ventilator shall be ETL Listed, listed by NSF and be in accordance with all of the recommendations set forth by NFPA 96. Filters tested to ASTM Standard F2519-05 by independent third party. All ventilators must meet all applicable codes.





MODEL:

SHBC-C-W-PA---

ADD THE OVERALL LENGTH (IN INCHES) OF THE VENTILATOR AFTER MODEL DESIGNATION

DAMPER TYPE
ND - NO DAMPER
FL - FUSIBLE LINK
T - THERMOSTAT

ADD THE OVERALL WIDTH (IN INCHES) OF THE VENTILATOR AFTER MODEL DESIGNATION

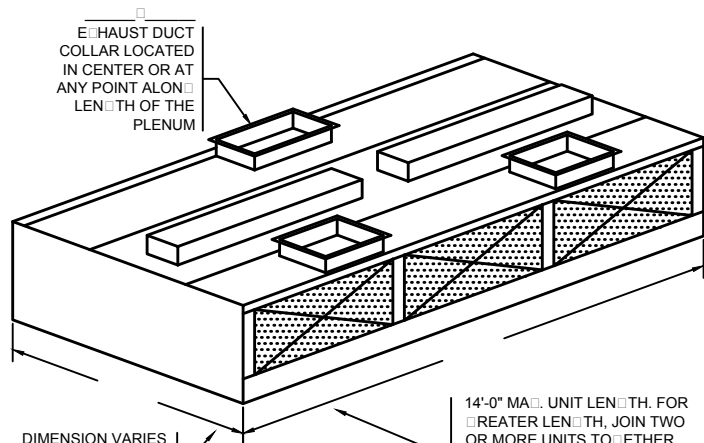

DIMENSION VARIES WITH DEPTH OF THE EQUIPMENT AND REQUIRED OVERHANG

14'-0" MAX. UNIT LENGTH. FOR GREATER LENGTH, JOIN TWO OR MORE UNITS TOGETHER. ALLOW 6" MIN. OVERHANG AT EACH END. IF CHARBROILER IS AT END, OVERHANG 12"

STANDARD LIGHT FIXTURES
() 100 WATT INCANDESCENT
() RECESSED INCANDESCENT
() RECESSED FLUORESCENT
(IF RECESSED FLUORESCENT SPECIFY SIZE)

CONSULT FACTORY FOR NON-STANDARD HEIGHTS

12" MIN. FRONT OVERHANG

6" MIN. SIDE OVERHANG
(12" MIN. SIDE OVERHANG FOR CHARBROILER)

ITEM # _____
EST. WEIGHT _____
LENGTH _____
WIDTH _____
HEIGHT _____
EXHAUST-CFM _____
DUCT SIZE _____
S.P. _____

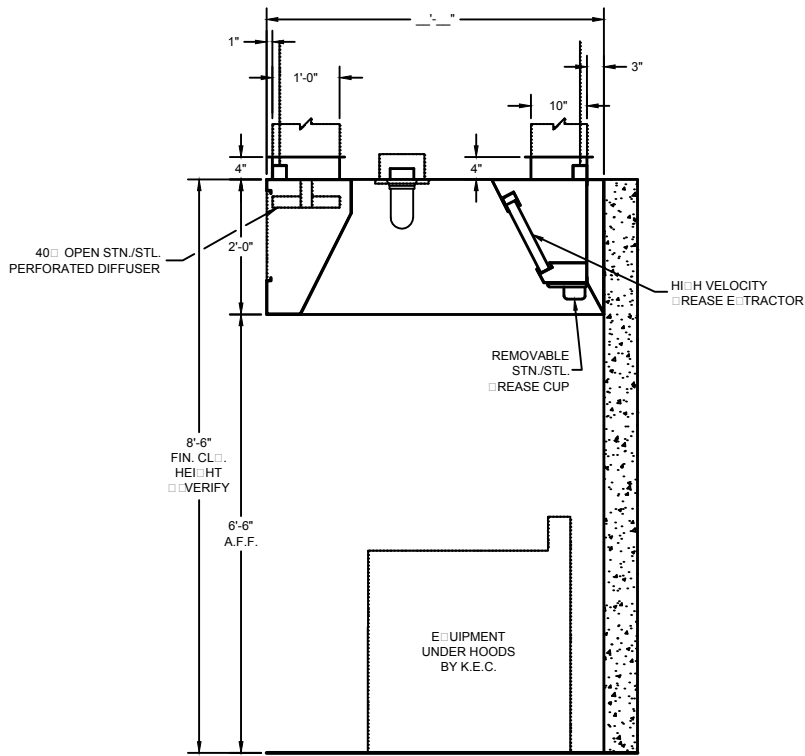

SECTION

DRAWINGS NOT TO SCALE

ENGINEERING DATA

Ventilator Length

Maximum ventilator length in a single section is 14'-0". For lengths greater than 14'-0", join two or more sections. Verify access conditions into building and kitchen space prior to length selection.

Ventilator Hanging Weight

Wt./lineal ft. Lbs. 90

NOTE: Refer to CADDY AirSystems

Master Engineering Data Sheet in engineering data section for determining light, medium, and heavy duty cooking equipment, C.F.M. requirements (exhaust and supply), duct collar sizes and static pressure requirements.

Electrical Requirements

Light fixtures to be powered by a 120/1/60 circuit.

Mechanical Requirements

The volume of exhaust required is a function of the type of cooking equipment served by the ventilator, and the type and volume of product cooked. Refer to the CADDY AirSystems Master Engineering Data Chart to determine exhaust volume, duct collar sizes, static pressure drop.



CADDY Air Systems

ITEM NO:

Model SHBC-C-W

Baffle Cartridge Ventilator With Ceiling Supply Plenum

PROJECT:

LOCATION:

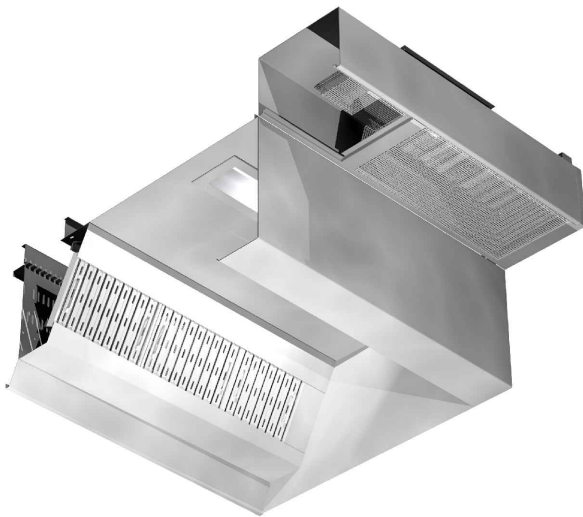
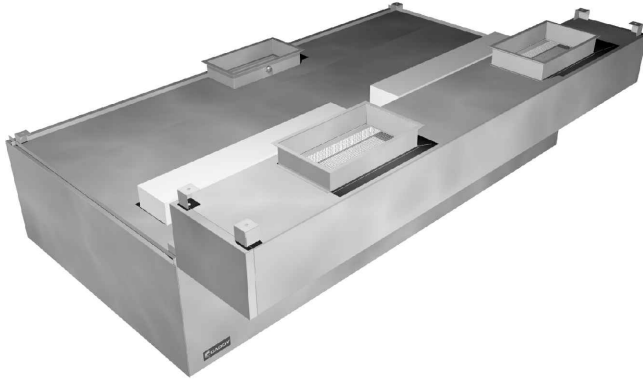

General Specifications

Furnish CADDY Air Systems Exhaust Ventilator Model SHBC-C-W as shown on the plans and as described in the following specifications.

General

Exhaust ventilator shall be constructed of 18 gauge type 300 series stainless steel. All exposed surfaces to have a #4 finish. Construction to meet all requirements of NFPA 96 and NSF Standard No. 2. To include necessary hanger brackets at front and rear suspending from building overhead structure.

Description

The CADDY Air Systems Model "SHBC" Series ventilator is a dry baffle cartridge type and is ETL listed under the standards as set forth in UL710 "Exhaust Hoods for Commercial Cooking Equipment." This ventilator is 95% grease extraction efficient when operated and maintained in accordance with design specifications.

This high efficiency is accomplished by utilizing removable stainless steel baffle cartridges containing a series of horizontal, self-draining baffles. As the air is drawn around the baffles, the grease, dust and lint particles are slung from the air stream by centrifugal force. As the liquefied grease is extracted, it is drained off via a trough into grease collection containers at each end of the ventilator. At the end of the cooking day or at scheduled intervals, the cartridges are removed for cleaning without having to climb up or onto the cooking equipment with the use of a baffle cartridge removal tool. Once removed, the baffle cartridges can be washed in either the dishwasher or soaked and rinsed off in a pot sink. Each baffle cartridge is a maximum of 19-1/2" long. Ventilator can also be equipped with an optional fusible link or thermostatically activated fire damper assembly.

Make-Up Air (Perimeter Down Discharge)

Ventilator shall have air registers along perimeter for down discharge of tempered make-up. Supply volume is 80% or designed to the desired air balance.

Application

Wall mounted exhaust only canopy style for use over all types of cooking equipment.

Light Fixtures

All light fixtures shall be pre-wired to a single connection point. Ventilators built in multiple sections to be furnished with junction boxes for ease of field connection by the electrical trades. Light bulbs furnished and installed by the Kitchen Equipment Contractor.

Exhaust Fans

Exhaust fans are to be provided and installed by others in compliance with local codes. Fans should be induced draft, squirrel cage design, equipped with backward inclined blades.

Fire Protection

NFPA 96 and local codes require a fire extinguishing system for protection of the duct collar and plenum of all ventilators, as well as for the protection of various cooking appliances such as deep fat fryers, griddles, ranges, and broilers, which may be a source of ignition of grease. Consult factory and local fire officials for exact requirements. UL Listed fire protection systems may be pre-piped by Caddy at the time of manufacture, assuring concealment of piping and detectors.

Approvals

Ventilator shall be ETL Listed, listed by NSF and be in accordance with all of the recommendations set forth by NFPA 96. Filters tested to ASTM Standard F2519-05 by independent third party. All ventilators must meet all applicable codes.





MODEL:

SHBC-C-W- - -

ADD THE OVERALL LENGTH (IN INCHES) OF THE VENTILATOR AFTER MODEL DESIGNATION

DAMPER TYPE
ND - NO DAMPER
FL - FUSIBLE LINK
T - THERMOSTAT

ADD THE OVERALL WIDTH (IN INCHES) OF THE VENTILATOR AFTER MODEL DESIGNATION

EXHAUST DUCT COLLAR LOCATED IN CENTER OR AT ANY POINT ALONG LENGTH OF THE PLENUM

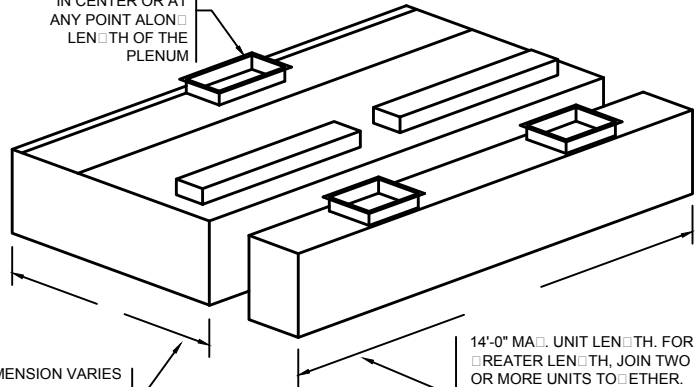

14'-0" MAX. UNIT LENGTH. FOR GREATER LENGTH, JOIN TWO OR MORE UNITS TOGETHER. ALLOW 6" MIN. OVERHANG AT EACH END. IF CHARBROILER IS AT END, OVERHANG 12"

DIMENSION VARIES WITH DEPTH OF THE EQUIPMENT AND REQUIRED OVERHANG

STANDARD LIGHT FIXTURES
() 100 WATT INCANDESCENT
() RECESSED INCANDESCENT
() RECESSED FLUORESCENT
(IF RECESSED FLUORESCENT SPECIFY SIZE)

CONSULT FACTORY FOR NON-STANDARD HEIGHTS
22" MIN. FRONT OVERHANG
6" MIN. SIDE OVERHANG
(12" MIN. SIDE OVERHANG FOR CHARBROILER)

ITEM

EST. WEIGHT

LENGTH

WIDTH

HEIGHT

EXHAUST-CFM

DUCT SIZE

S.P.

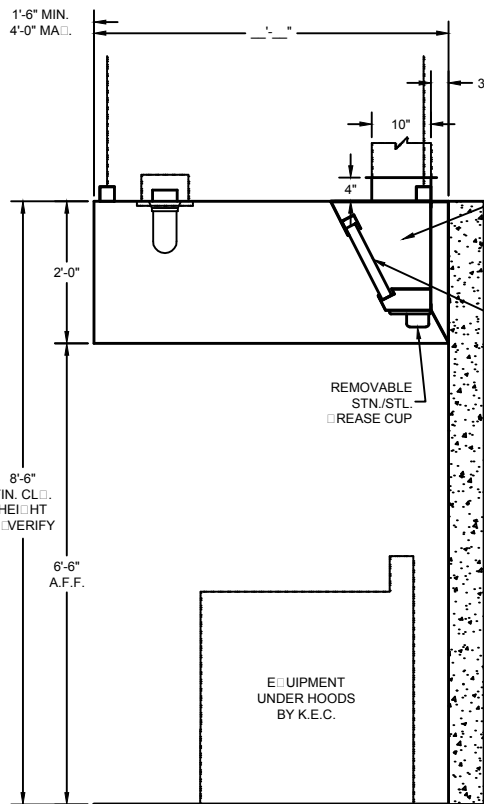
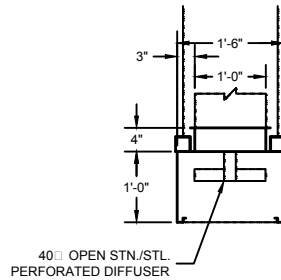

DRAWINGS NOT TO SCALE

ENGINEERING DATA

Ventilator Length

Maximum ventilator length in a single section is 14'-0". For lengths greater than 14'-0", join two or more sections. Verify access conditions into building and kitchen space prior to length selection.

Ventilator Hanging Weight

Wt./lineal ft. Lbs. 90

NOTE: Refer to **CADDY AirSystems**

Master Engineering Data Sheet in engineering data section for determining light, medium, and heavy duty cooking equipment, C.F.M. requirements (exhaust and supply), duct collar sizes and static pressure requirements.

Electrical Requirements

Light fixtures to be powered by a 120/1/60 circuit.

Mechanical Requirements

The volume of exhaust required is a function of the type of cooking equipment served by the ventilator, and the type and volume of product cooked. Refer to the **CADDY AirSystems** Master Engineering Data Chart to determine exhaust volume, duct collar sizes, static pressure drop.



CADDY Air Systems

ITEM NO:

Model SHBC-C-I Baffle Cartridge Ventilator

PROJECT:

LOCATION:

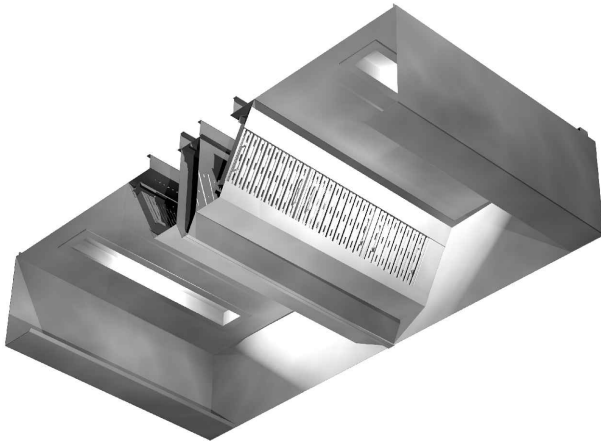
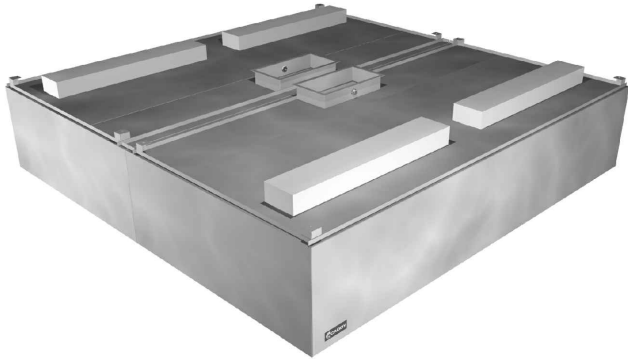

General Specifications

Furnish CADDY *AirSystems* Exhaust Ventilator Model **SHBC-C-I** as shown on the plans and as described in the following specifications.

General

Exhaust ventilator shall be constructed of 18 gauge type 300 series stainless steel. All exposed surfaces to have a #4 finish. Construction to meet all requirements of NFPA 96 and NSF Standard No. 2. To include necessary hanger brackets at front and rear suspending from building overhead structure.

Description

The CADDY *AirSystems* Model "SHBC" Series ventilator is a dry baffle cartridge type and is ETL listed under the standards as set forth in UL710 "Exhaust Hoods for Commercial Cooking Equipment." This ventilator is 95% grease extraction efficient when operated and maintained in accordance with design specifications. This high efficiency is accomplished by utilizing removable stainless steel baffle cartridges containing a series of horizontal, self-draining baffles. As the air is drawn around the baffles, the grease, dust and lint particles are slung from the air stream by centrifugal force. As the liquefied grease is extracted, it is drained off via a trough into grease collection containers at each end of the ventilator. At the end of the cooking day or at scheduled intervals, the cartridges are removed for cleaning without having to climb up or onto the cooking equipment with the use of a baffle cartridge removal tool. Once removed, the baffle cartridges can be washed in either the dishwasher or soaked and rinsed off in a pot sink. Each baffle cartridge is a maximum of 19-1/2" long. Ventilator can also be equipped with an optional fusible link or thermostatically activated fire damper assembly.

Application

Island mounted exhaust only canopy style for use over all types of cooking equipment.

Light Fixtures

All light fixtures shall be pre-wired to a single connection point. Ventilators built in multiple sections to be furnished with junction boxes for ease of field connection by the electrical trades. Light bulbs furnished and installed by the Kitchen Equipment Contractor.

Exhaust Fans

Exhaust fans are to be provided and installed by others in compliance with local codes. **Fans should be induced draft, squirrel cage design, equipped with backward inclined blades.**

Fire Protection

NFPA 96 and local codes require a fire extinguishing system for protection of the duct collar and plenum of all ventilators, as well as for the protection of various cooking appliances such as deep fat fryers, griddles, ranges, and broilers, which may be a source of ignition of grease. Consult factory and local fire officials for exact requirements. UL Listed fire protection systems may be pre-piped by Caddy at the time of manufacture, assuring concealment of piping and detectors.

Approvals

Ventilator shall be ETL Listed, listed by NSF and be in accordance with all of the recommendations set forth by NFPA 96. Filters tested to ASTM Standard F2519-05 by independent third party. All ventilators must meet all applicable codes.

CADDY CORPORATION
509 Sharptown Road P.O. Box 345
Bridgeport, NJ 08014-0345
Tel: 856-467-4222 Fax: 856-467-5511
internet: www.caddycorp.com



MODEL:

SHBC-C-I---

ADD THE OVERALL LENGTH (IN INCHES) OF THE VENTILATOR AFTER MODEL DESIGNATION

DAMPER TYPE
 ND - NO DAMPER
 FL - FUSIBLE LINK
 T - THERMOSTAT

ADD THE OVERALL WIDTH (IN INCHES) OF THE VENTILATOR AFTER MODEL DESIGNATION

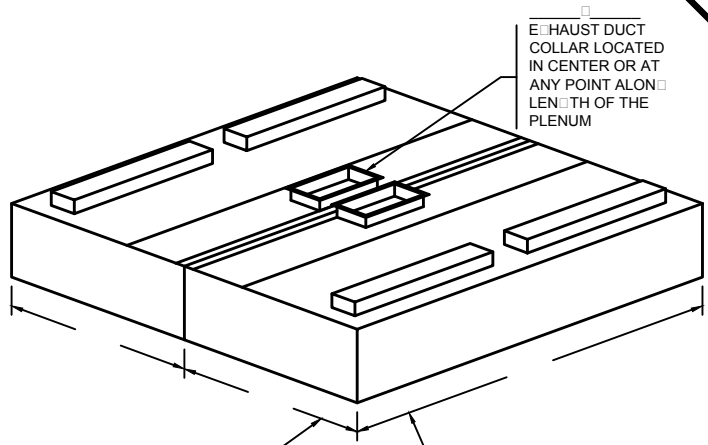

EXHAUST DUCT COLLAR LOCATED IN CENTER OR AT ANY POINT ALONG LENGTH OF THE PLENUM

DIMENSION VARIES WITH DEPTH OF THE EQUIPMENT AND REQUIRED OVERHANG

14'-0" MAX. UNIT LENGTH. FOR GREATER LENGTH, JOIN TWO OR MORE UNITS TOGETHER. ALLOW 6" MIN. OVERHANG AT EACH END. IF CHARBROILER IS AT END, OVERHANG 12"

STANDARD LIGHT FIXTURES
 () 100 WATT INCANDESCENT
 () RECESSED INCANDESCENT
 () RECESSED FLUORESCENT
 (IF RECESSED FLUORESCENT SPECIFY SIZE)

CONSULT FACTORY FOR NON-STANDARD HEIGHTS
 12" MIN. FRONT OVERHANG
 6" MIN. SIDE OVERHANG (12" MIN. SIDE OVERHANG FOR CHARBROILER)

ITEM # _____
 EST. WEIGHT _____
 LENGTH _____
 WIDTH _____
 HEIGHT _____
 EXHAUST-CFM _____
 DUCT SIZE _____
 S.P. _____

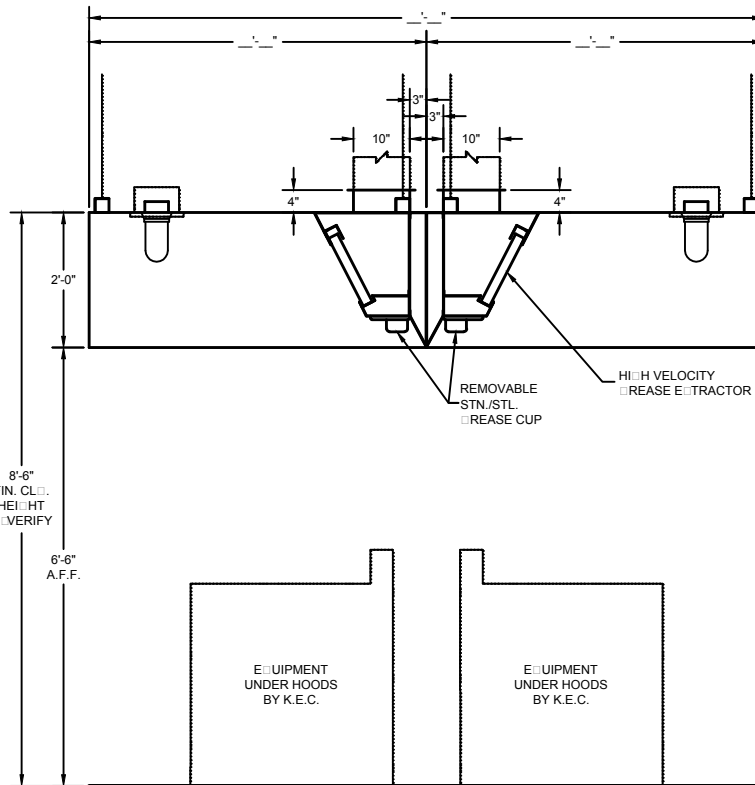

SECTION

DRAWINGS NOT TO SCALE

ENGINEERING DATA

Ventilator Length

Maximum ventilator length in a single section is 14'-0". For lengths greater than 14'-0", join two or more sections. Verify access conditions into building and kitchen space prior to length selection.

Ventilator Hanging Weight

Wt./lineal ft. Lbs. 75

NOTE: Refer to **CADDY AirSystems**

Master Engineering Data Sheet in engineering data section for determining light, medium, and heavy duty cooking equipment, C.F.M. requirements (exhaust and supply), duct collar sizes and static pressure requirements.

Electrical Requirements

Light fixtures to be powered by a 120/1/60 circuit.

Mechanical Requirements

The volume of exhaust required is a function of the type of cooking equipment served by the ventilator, and the type and volume of product cooked. Refer to the **CADDY AirSystems** Master Engineering Data Chart to determine exhaust volume, duct collar sizes, static pressure drop.



CADDY Air Systems

Model SHBC-C-I-PA Baffle Cartridge Ventilator

ITEM NO:

PROJECT:

LOCATION:

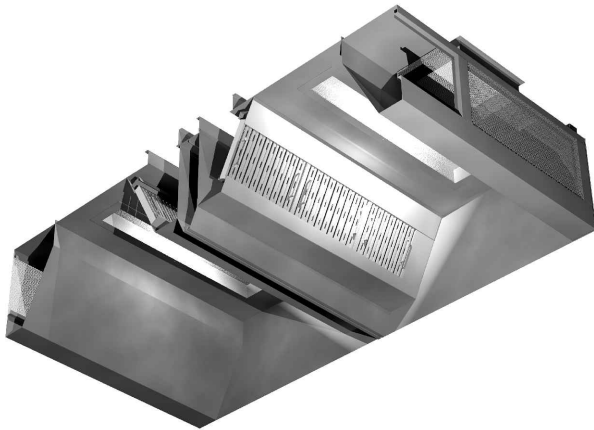
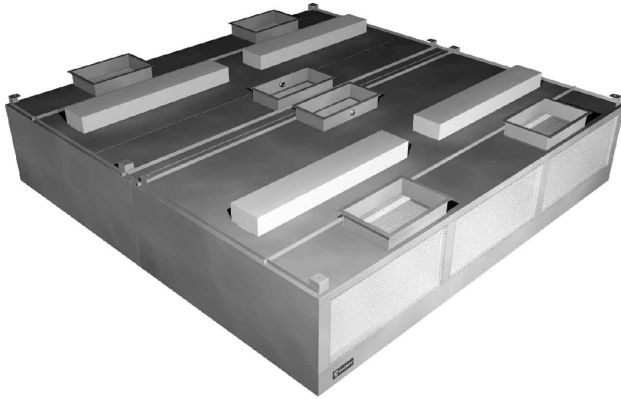

General Specifications

Furnish CADDY **AirSystems** Exhaust Ventilator Model **SHBC-C-I-PA** as shown on the plans and as described in the following specifications.

General

Exhaust ventilator shall be constructed of 18 gauge type 304 series stainless steel. All exposed surfaces to have a #4 finish. Construction to meet all requirements of NFPA 96 and NSF Standard No. 2. To include necessary hanger brackets at front and rear suspending from building overhead structure.

Description

The CADDY **AirSystems** Model "SHBC" Series ventilator is a dry baffle cartridge type and is ETL listed under the standards as set forth in UL710 "Exhaust Hoods for Commercial Cooking Equipment." This ventilator is 95% grease extraction efficient when operated and maintained in accordance with design specifications.

This high efficiency is accomplished by utilizing removable stainless steel baffle cartridges containing a series of horizontal, self-draining baffles. As the air is drawn around the baffles, the grease, dust and lint particles are slung from the air stream by centrifugal force. As the liquefied grease is extracted, it is drained off via a trough into grease collection containers at each end of the ventilator. At the end of the cooking day or at scheduled intervals, the cartridges are removed for cleaning without having to climb up or onto the cooking equipment with the use of a baffle cartridge removal tool. Once removed, the baffle cartridges can be washed in either the dishwasher or soaked and rinsed off in a pot sink. Each baffle cartridge is a maximum of 19-1/2" long. Ventilator can also be equipped with an optional fusible link or thermostatically activated fire damper assembly.

Make-Up Air (Front Face Discharge)

Ventilator shall have 40% open stainless steel perforated screens along front face for discharge of tempered make-up air. Supply volume is 80% or designed to the desired air balance.

Application

Island style cooking applications for use over all types of cooking equipment where integral make-up air is required.

Light Fixtures

All light fixtures shall be pre-wired to a single connection point. Ventilators built in multiple sections to be furnished with junction boxes for ease of field connection by the electrical trades. Light bulbs furnished and installed by the Kitchen Equipment Contractor.

Exhaust Fans

Exhaust fans are to be provided and installed by others in compliance with local codes. **Fans should be induced draft, squirrel cage design, equipped with backward inclined blades.**

Fire Protection

NFPA 96 and local codes require a fire extinguishing system for protection of the duct collar and plenum of all ventilators, as well as for the protection of various cooking appliances such as deep fat fryers, griddles, ranges, and broilers, which may be a source of ignition of grease. Consult factory and local fire officials for exact requirements. UL Listed fire protection systems may be pre-piped by Caddy at the time of manufacture, assuring concealment of piping and detectors.

Approvals

Ventilator shall be ETL Listed, listed by NSF and be in accordance with all of the recommendations set forth by NFPA 96. Filters tested to ASTM Standard F2519-05 by independent third party. All ventilators must meet all applicable codes.

CADDY CORPORATION
509 Sharptown Road P.O. Box 345
Bridgeport, NJ 08014-0345
Tel: 856-467-4222 Fax: 856-467-5511
internet: www.caddycorp.com



MODEL:

SHBC-C-I-PA---

ADD THE OVERALL LENGTH (IN INCHES) OF THE VENTILATOR AFTER MODEL DESIGNATION

DAMPER TYPE
ND - NO DAMPER
FL - FUSIBLE LINK
T - THERMOSTAT

ADD THE OVERALL WIDTH (IN INCHES) OF THE VENTILATOR AFTER MODEL DESIGNATION

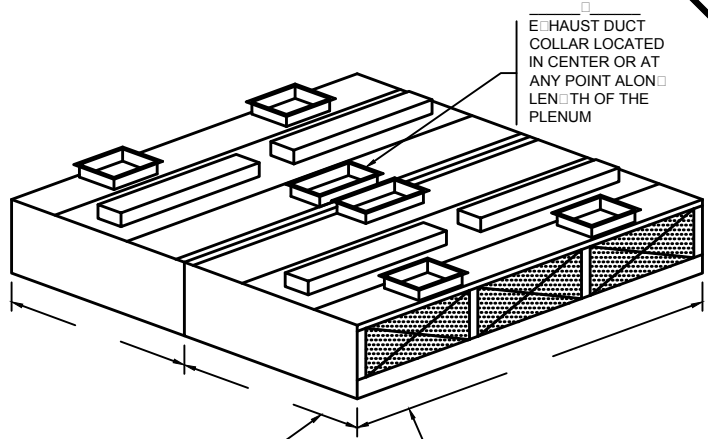

EXHAUST DUCT COLLAR LOCATED IN CENTER OR AT ANY POINT ALONG LENGTH OF THE PLENUM

DIMENSION VARIES WITH DEPTH OF THE EQUIPMENT AND REQUIRED OVERHANG

14'-0" MAX. UNIT LENGTH. FOR GREATER LENGTH, JOIN TWO OR MORE UNITS TOGETHER. ALLOW 6" MIN. OVERHANG AT EACH END. IF CHARBROILER IS AT END, OVERHANG 12"

STANDARD LIGHT FIXTURES
() 100 WATT INCANDESCENT
() RECESSED INCANDESCENT
() RECESSED FLUORESCENT
(IF RECESSED FLUORESCENT SPECIFY SIZE)

CONSULT FACTORY FOR NON-STANDARD HEIGHTS

12" MIN. FRONT OVERHANG

6" MIN. SIDE OVERHANG (12" MIN. SIDE OVERHANG FOR CHARBROILER)

ITEM # _____
EST. WEIGHT _____
LENGTH _____
WIDTH _____
HEIGHT _____
EXHAUST-CFM _____
DUCT SIZE _____
S.P. _____

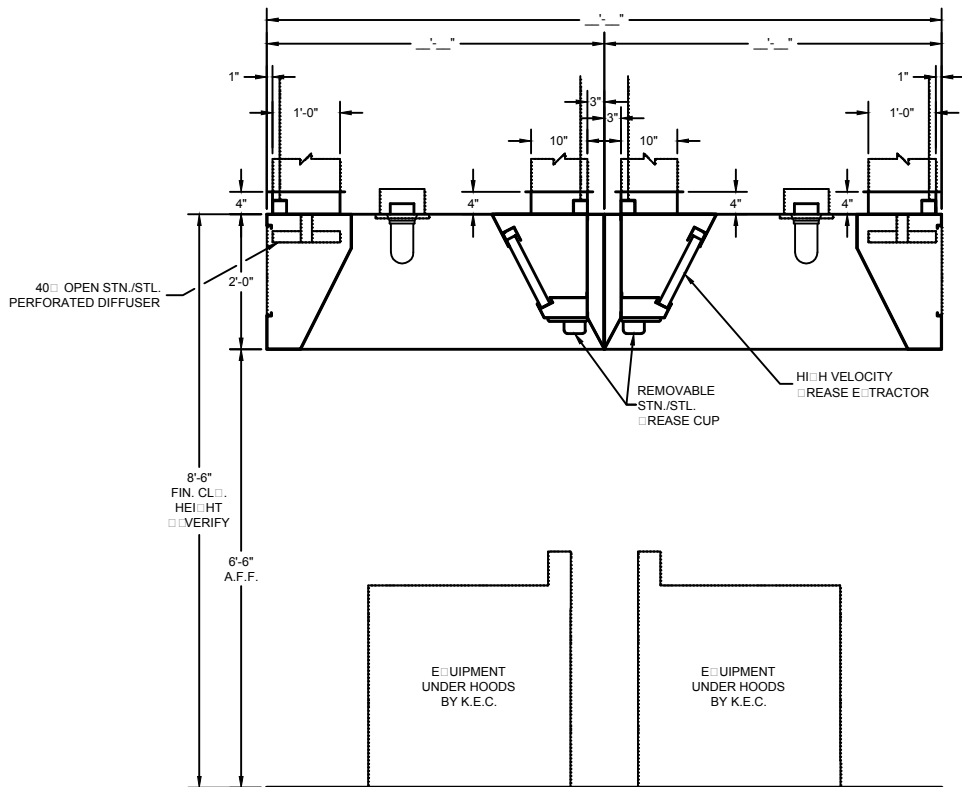

SECTION

DRAWINGS NOT TO SCALE

ENGINEERING DATA

Ventilator Length

Maximum ventilator length in a single section is 14'-0". For lengths greater than 14'-0", join two or more sections. Verify access conditions into building and kitchen space prior to length selection.

Ventilator Hanging Weight

Wt./lineal ft. Lbs. 90

NOTE: Refer to CADDY AirSystems

Master Engineering Data Sheet in engineering data section for determining light, medium, and heavy duty cooking equipment, C.F.M. requirements (exhaust and supply), duct collar sizes and static pressure requirements.

Electrical Requirements

Light fixtures to be powered by a 120/1/60 circuit.

Mechanical Requirements

The volume of exhaust required is a function of the type of cooking equipment served by the ventilator, and the type and volume of product cooked. Refer to the CADDY AirSystems Master Engineering Data Chart to determine exhaust volume, duct collar sizes, static pressure drop.



CADDY Air Systems

ITEM NO:

Model SHBC-C-I

PROJECT:

Baffle Cartridge Ventilator With Ceiling Supply Plenum

LOCATION:

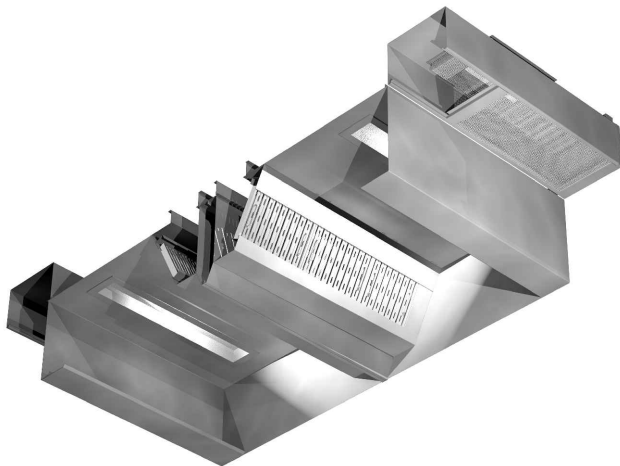
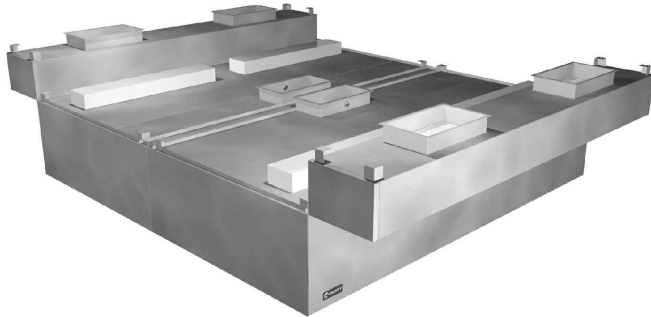

General Specifications

Furnish CADDY AirSystems Exhaust Ventilator Model SHBC-C-I as shown on the plans and as described in the following specifications.

General

Exhaust ventilator shall be constructed of 18 gauge type 300 series stainless steel. All exposed surfaces to have a #4 finish. Construction to meet all requirements of NFPA 96 and NSF Standard No. 2. To include necessary hanger brackets at front and rear suspending from building overhead structure.

Description

The CADDY AirSystems Model "SHBC" Series ventilator is a dry baffle cartridge type and is ETL listed under the standards as set forth in UL710 "Exhaust Hoods for Commercial Cooking Equipment." This ventilator is 95% grease extraction efficient when operated and maintained in accordance with design specifications.

This high efficiency is accomplished by utilizing removable stainless steel baffle cartridges containing a series of horizontal, self-draining baffles. As the air is drawn around the baffles, the grease, dust and lint particles are slung from the air stream by centrifugal force. As the liquefied grease is extracted, it is drained off via a trough into grease collection containers at each end of the ventilator. At the end of the cooking day or at scheduled intervals, the cartridges are removed for cleaning without having to climb up or onto the cooking equipment with the use of a baffle cartridge removal tool. Once removed, the baffle cartridges can be washed in either the dishwasher or soaked and rinsed off in a pot sink. Each baffle cartridge is a maximum of 19-1/2" long. Ventilator can also be equipped with an optional fusible link or thermostatically activated fire damper assembly.

Make-Up Air (Perimeter Down Discharge)

Ventilator shall have air registers along perimeter for down discharge of tempered make-up. Supply volume is 80% or designed to the desired air balance.

Application

Island style cooking applications for use over all types of cooking equipment where integral make-up air is required.

Light Fixtures

All light fixtures shall be pre-wired to a single connection point. Ventilators built in multiple sections to be furnished with junction boxes for ease of field connection by the electrical trades. Light bulbs furnished and installed by the Kitchen Equipment Contractor.

Exhaust Fans

Exhaust fans are to be provided and installed by others in compliance with local codes. **Fans should be induced draft, squirrel cage design, equipped with backward inclined blades.**

Fire Protection

NFPA 96 and local codes require a fire extinguishing system for protection of the duct collar and plenum of all ventilators, as well as for the protection of various cooking appliances such as deep fat fryers, griddles, ranges, and broilers, which may be a source of ignition of grease. Consult factory and local fire officials for exact requirements. UL Listed fire protection systems may be pre-piped by Caddy at the time of manufacture, assuring concealment of piping and detectors.

Approvals

Ventilator shall be ETL Listed, listed by NSF and be in accordance with all of the recommendations set forth by NFPA 96. Filters tested to ASTM Standard F2519-05 by independent third party. Filters tested to ASTM Standard F2519-05 by independent third party. All ventilators must meet all applicable codes.

CADDY CORPORATION
509 Sharptown Road P.O. Box 345
Bridgeport, NJ 08014-0345
Tel: 856-467-4222 Fax: 856-467-5511
internet: www.caddycorp.com



MODEL:

SHBC-C-I---

ADD THE OVERALL LENGTH (IN INCHES) OF THE VENTILATOR AFTER MODEL DESIGNATION

DAMPER TYPE
ND - NO DAMPER
FL - FUSIBLE LINK
T - THERMOSTAT

ADD THE OVERALL WIDTH (IN INCHES) OF THE VENTILATOR AFTER MODEL DESIGNATION

EXHAUST DUCT COLLAR LOCATED IN CENTER OR AT ANY POINT ALONG LENGTH OF THE PLENUM

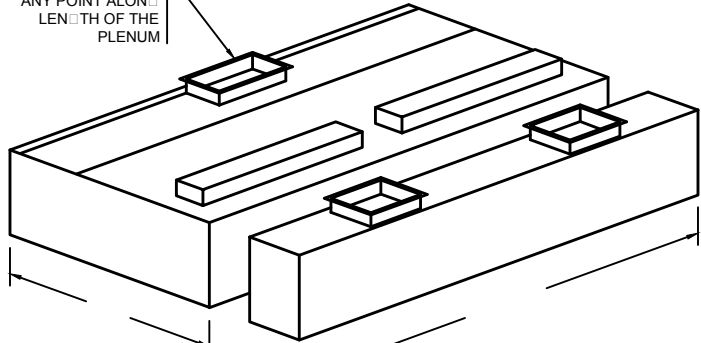

DIMENSION VARIES WITH DEPTH OF THE EQUIPMENT AND REQUIRED OVERHANG

14'-0" MAX. UNIT LENGTH. FOR GREATER LENGTH, JOIN TWO OR MORE UNITS TOGETHER. ALLOW 6" MIN. OVERHANG AT EACH END. IF CHARBROILER IS AT END, OVERHANG 12"

STANDARD LIGHT FIXTURES
() 100 WATT INCANDESCENT
() RECESSED INCANDESCENT
() RECESSED FLUORESCENT
(IF RECESSED FLUORESCENT SPECIFY SIZE)

CONSULT FACTORY FOR NON-STANDARD HEIGHTS

22" MIN. FRONT OVERHANG

6" MIN. SIDE OVERHANG (12" MIN. SIDE OVERHANG FOR CHARBROILER)

ITEM # _____
EST. WEIGHT _____
LENGTH _____
WIDTH _____
HEIGHT _____
EXHAUST-CFM _____
DUCT SIZE _____
S.P. _____

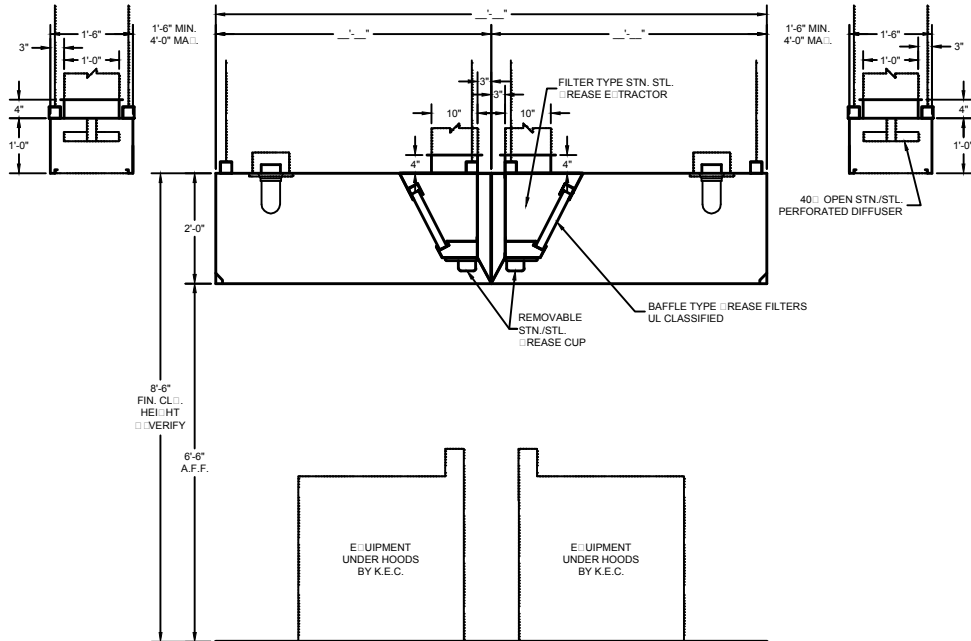

DRAWINGS NOT TO SCALE

ENGINEERING DATA

Ventilator Length

Maximum ventilator length in a single section is 14'-0". For lengths greater than 14'-0", join two or more sections. Verify access conditions into building and kitchen space prior to length selection.

Ventilator Hanging Weight

Wt./lineal ft. Lbs. 90

NOTE: Refer to **CADDY AirSystems**

Master Engineering Data Sheet in engineering data section for determining light, medium, and heavy duty cooking equipment, C.F.M. requirements (exhaust and supply), duct collar sizes and static pressure requirements.

Electrical Requirements

Light fixtures to be powered by a 120/1/60 circuit.

Mechanical Requirements

The volume of exhaust required is a function of the type of cooking equipment served by the ventilator, and the type and volume of product cooked. Refer to the **CADDY AirSystems** Master Engineering Data Chart to determine exhaust volume, duct collar sizes, static pressure drop.



CADDY Air Systems

Model SHBC-C-II Baffle Cartridge Ventilator

ITEM NO:

PROJECT:

LOCATION:

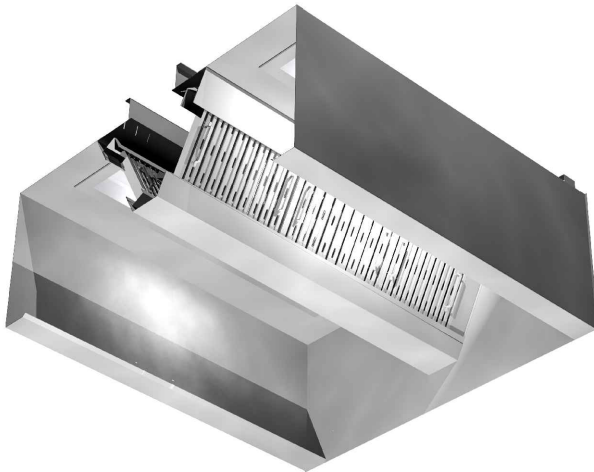

General Specifications

Furnish CADDY Air Systems Exhaust Ventilator Model **SHBC-C-II** as shown on the plans and as described in the following specifications.

General

Exhaust ventilator shall be constructed of 18 gauge type 300 series stainless steel. All exposed surfaces to have a #4 finish. Construction to meet all requirements of NFPA 96 and NSF Standard No. 2. To include necessary hanger brackets at front and rear suspending from building overhead structure.

Description

The CADDY Air Systems Model "SHBC" Series ventilator is a dry baffle cartridge type and is ETL listed under the standards as set forth in UL710 "Exhaust Hoods for Commercial Cooking Equipment." This ventilator is 95% grease extraction efficient when operated and maintained in accordance with design specifications. This high efficiency is accomplished by utilizing removable stainless steel baffle cartridges containing a series of horizontal, self-draining baffles. As the air is drawn around the baffles, the grease, dust and lint particles are slung from the air stream by centrifugal force. As the liquefied grease is extracted, it is drained off via a trough into grease collection containers at each end of the ventilator. At the end of the cooking day or at scheduled intervals, the cartridges are removed for cleaning without having to climb up or onto the cooking equipment with the use of a baffle cartridge removal tool. Once removed, the baffle cartridges can be washed in either the dishwasher or soaked and rinsed off in a pot sink. Each baffle cartridge is a maximum of 19-1/2" long. Ventilator can also be equipped with an optional fusible link or thermostatically activated fire damper assembly.

Application

Island mounted exhaust only canopy style for use over all types of cooking equipment.

Light Fixtures

All light fixtures shall be pre-wired to a single connection point. Ventilators built in multiple sections to be furnished with junction boxes for ease of field connection by the electrical trades. Light bulbs furnished and installed by the Kitchen Equipment Contractor.

Exhaust Fans

Exhaust fans are to be provided and installed by others in compliance with local codes. **Fans should be induced draft, squirrel cage design, equipped with backward inclined blades.**

Fire Protection

NFPA 96 and local codes require a fire extinguishing system for protection of the duct collar and plenum of all ventilators, as well as for the protection of various cooking appliances such as deep fat fryers, griddles, ranges, and broilers, which may be a source of ignition of grease. Consult factory and local fire officials for exact requirements. UL Listed fire protection systems may be pre-piped by Caddy at the time of manufacture, assuring concealment of piping and detectors.

Approvals

Ventilator shall be ETL Listed, listed by NSF and be in accordance with all of the recommendations set forth by NFPA 96. Filters tested to ASTM Standard F2519-05 by independent third party. All ventilators must meet all applicable codes.

CADDY CORPORATION
509 Sharptown Road P.O. Box 345
Bridgeport, NJ 08014-0345
Tel: 856-467-4222 Fax: 856-467-5511
internet: www.caddycorp.com



MODEL:

SHBC-C-II---

ADD THE OVERALL LENGTH (IN INCHES) OF THE VENTILATOR AFTER MODEL DESIGNATION

DAMPER TYPE
ND - NO DAMPER
FL - FUSIBLE LINK
T - THERMOSTAT

ADD THE OVERALL WIDTH (IN INCHES) OF THE VENTILATOR AFTER MODEL DESIGNATION

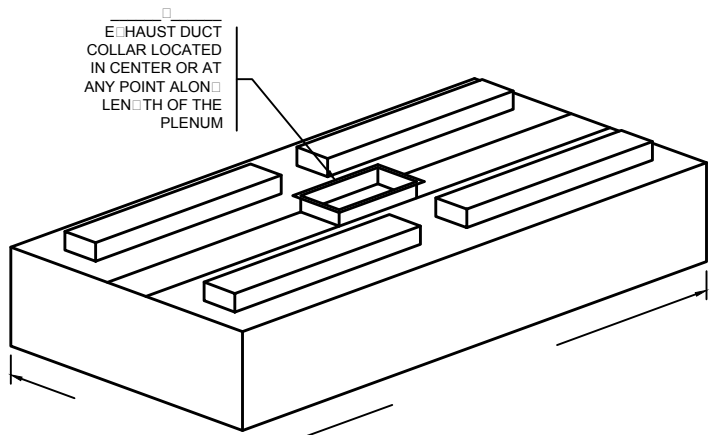

EXHAUST DUCT COLLAR LOCATED IN CENTER OR AT ANY POINT ALONG LENGTH OF THE PLENUM

STANDARD LIGHT FIXTURES
() 100 WATT INCANDESCENT
() RECESSED INCANDESCENT
() RECESSED FLUORESCENT
(IF RECESSED FLUORESCENT SPECIFY SIZE)

CONSULT FACTORY FOR NON-STANDARD HEIGHTS

12" MIN. FRONT OVERHANG

6" MIN. SIDE OVERHANG
(12" MIN. SIDE OVERHANG FOR CHARBROILER)

DIMENSION VARIES WITH DEPTH OF THE EQUIPMENT AND REQUIRED OVERHANG

14'-0" MAX. UNIT LENGTH. FOR GREATER LENGTH, JOIN TWO OR MORE UNITS TOGETHER. ALLOW 6" MIN. OVERHANG AT EACH END. IF CHARBROILER IS AT END, OVERHANG 12"

ITEM # _____
EST. WEIGHT _____
LENGTH _____
WIDTH _____
HEIGHT _____
EXHAUST-CFM _____
DUCT SIZE _____
S.P. _____

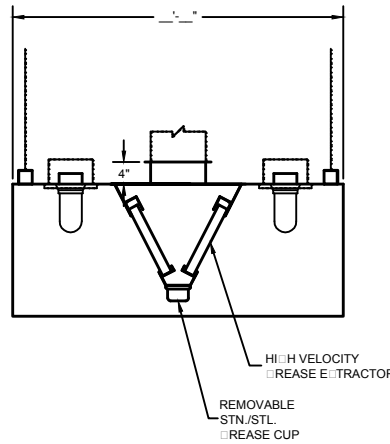

HIGH VELOCITY GREASE EXTRACTOR
REMOVABLE STN./STL. GREASE CUP

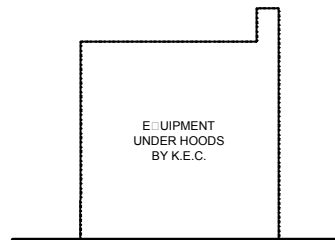

EQUIPMENT UNDER HOODS BY K.E.C.

SECTION

DRAWINGS NOT TO SCALE

ENGINEERING DATA

Ventilator Length

Maximum ventilator length in a single section is 14'-0". For lengths greater than 14'-0", join two or more sections. Verify access conditions into building and kitchen space prior to length selection.

Ventilator Hanging Weight

Wt./lineal ft. Lbs. 90

NOTE: Refer to **CADDY AirSystems**

Master Engineering Data Sheet in engineering data section for determining light, medium, and heavy duty cooking equipment, C.F.M. requirements (exhaust and supply), duct collar sizes and static pressure requirements.

Electrical Requirements

Light fixtures to be powered by a 120/1/60 circuit.

Mechanical Requirements

The volume of exhaust required is a function of the type of cooking equipment served by the ventilator, and the type and volume of product cooked. Refer to the **CADDY AirSystems** Master Engineering Data Chart to determine exhaust volume, duct collar sizes, static pressure drop.



CADDY Air Systems

Model SHBC-C-II-PA Baffle Cartridge Ventilator

ITEM NO:

PROJECT:

LOCATION:

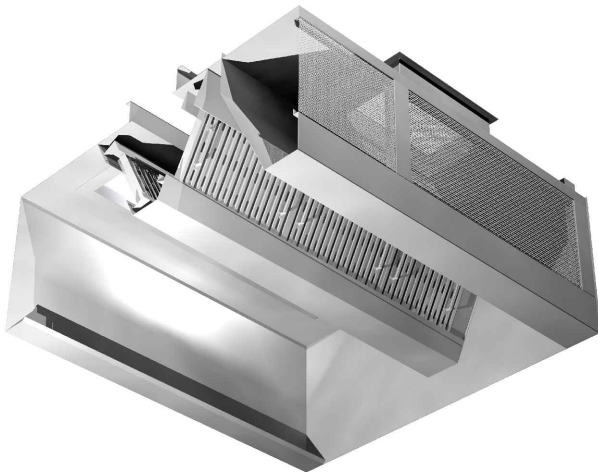
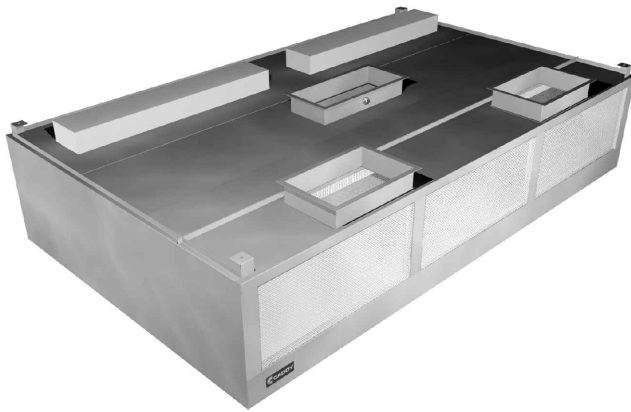

General Specifications

Furnish CADDY *AirSystems* Exhaust Ventilator Model SHBC-C-II-PA as shown on the plans and as described in the following specifications.

General

Exhaust ventilator shall be constructed of 18 gauge type 300 series stainless steel. All exposed surfaces to have a #4 finish. Construction to meet all requirements of NFPA 96 and NSF Standard No. 2. To include necessary hanger brackets at front and rear suspending from building overhead structure.

Description

The CADDY *AirSystems* Model "SHBC" Series ventilator is a dry baffle cartridge type and is ETL listed under the standards as set forth in UL710 "Exhaust Hoods for Commercial Cooking Equipment." This ventilator is 95% grease extraction efficient when operated and maintained in accordance with design specifications.

This high efficiency is accomplished by utilizing removable stainless steel baffle cartridges containing a series of horizontal, self-draining baffles. As the air is drawn around the baffles, the grease, dust and lint particles are slung from the air stream by centrifugal force. As the liquefied grease is extracted, it is drained off via a trough into grease collection containers at each end of the ventilator. At the end of the cooking day or at scheduled intervals, the cartridges are removed for cleaning without having to climb up or onto the cooking equipment with the use of a baffle cartridge removal tool. Once removed, the baffle cartridges can be washed in either the dishwasher or soaked and rinsed off in a pot sink. Each baffle cartridge is a maximum of 19-1/2" long. Ventilator can also be equipped with an optional fusible link or thermostatically activated fire damper assembly.

Make-Up Air (Front Face Register Discharge)

Ventilator shall have air registers along front face for discharge of tempered make-up air. Supply volume is 80 cfm, or designed to the desired air balance.

Application

Island style cooking applications for use over all types of cooking equipment where integral make-up air is required.

Light Fixtures

All light fixtures shall be pre-wired to a single connection point. Ventilators built in multiple sections to be furnished with junction boxes for ease of field connection by the electrical trades. Light bulbs furnished and installed by the Kitchen Equipment Contractor.

Exhaust Fans

Exhaust fans are to be provided and installed by others in compliance with local codes. **Fans should be induced draft, squirrel cage design, equipped with backward inclined blades.**

Fire Protection

NFPA 96 and local codes require a fire extinguishing system for protection of the duct collar and plenum of all ventilators, as well as for the protection of various cooking appliances such as deep fat fryers, griddles, ranges, and broilers, which may be a source of ignition of grease. Consult factory and local fire officials for exact requirements. UL Listed fire protection systems may be pre-piped by Caddy at the time of manufacture, assuring concealment of piping and detectors.

Approvals

Ventilator shall be ETL Listed, listed by NSF and be in accordance with all of the recommendations set forth by NFPA 96. Filters tested to ASTM Standard F2519-05 by independent third party. All ventilators must meet all applicable codes.

CADDY CORPORATION
509 Sharptown Road P.O. Box 345
Bridgeport, NJ 08014-0345
Tel: 856-467-4222 Fax: 856-467-5511
internet: www.caddycorp.com



MODEL:

SHBC-C-II-PA---

ADD THE OVERALL LENGTH (IN INCHES) OF THE VENTILATOR AFTER MODEL DESIGNATION

DAMPER TYPE
ND - NO DAMPER
FL - FUSIBLE LINK
T - THERMOSTAT

ADD THE OVERALL WIDTH (IN INCHES) OF THE VENTILATOR AFTER MODEL DESIGNATION

STANDARD LIGHT FIXTURES
() 100 WATT INCANDESCENT
() RECESSED INCANDESCENT
() RECESSED FLUORESCENT
(IF RECESSED FLUORESCENT SPECIFY SIZE)

CONSULT FACTORY FOR NON-STANDARD HEIGHTS

12" MIN. FRONT OVERHANG

6" MIN. SIDE OVERHANG (12" MIN. SIDE OVERHANG FOR CHARBROILER)

ITEM # _____
EST. WEIGHT _____
LENGTH _____
WIDTH _____
HEIGHT _____
EXHAUST-CFM _____
DUCT SIZE _____
S.P. _____

EXHAUST DUCT COLLAR LOCATED IN CENTER OR AT ANY POINT ALONG LENGTH OF THE PLENUM

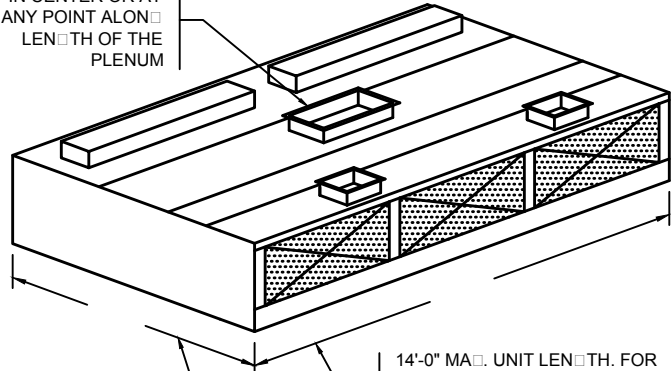

DIMENSION VARIES WITH DEPTH OF THE EQUIPMENT AND REQUIRED OVERHANG

14'-0" MAX. UNIT LENGTH. FOR GREATER LENGTH, JOIN TWO OR MORE UNITS TOGETHER. ALLOW 6" MIN. OVERHANG AT EACH END. IF CHARBROILER IS AT END, OVERHANG 12"

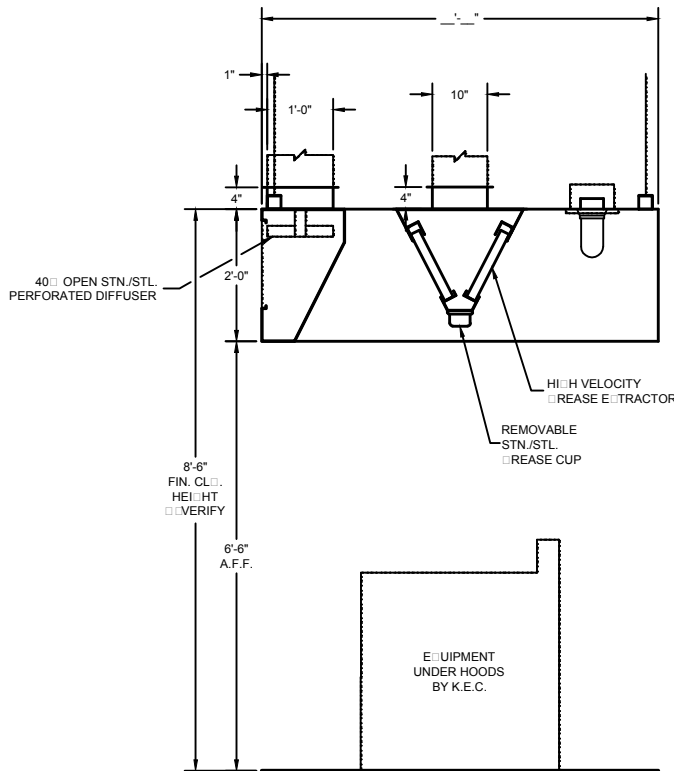

SECTION

DRAWINGS NOT TO SCALE

ENGINEERING DATA

Ventilator Length

Maximum ventilator length in a single section is 14'-0". For lengths greater than 14'-0", join two or more sections. Verify access conditions into building and kitchen space prior to length selection.

Ventilator Hanging Weight

Wt./lineal ft. Lbs. 105

NOTE: Refer to CADDY AirSystems

Master Engineering Data Sheet in engineering data section for determining light, medium, and heavy duty cooking equipment, C.F.M. requirements (exhaust and supply), duct collar sizes and static pressure requirements.

Electrical Requirements

Light fixtures to be powered by a 120/1/60 circuit.

Mechanical Requirements

The volume of exhaust required is a function of the type of cooking equipment served by the ventilator, and the type and volume of product cooked. Refer to the CADDY AirSystems Master Engineering Data Chart to determine exhaust volume, duct collar sizes, static pressure drop.



CADDY Air Systems

ITEM NO:

Model SHBC-C-II

Baffle Cartridge Ventilator With Ceiling Supply Plenum

PROJECT:

LOCATION:

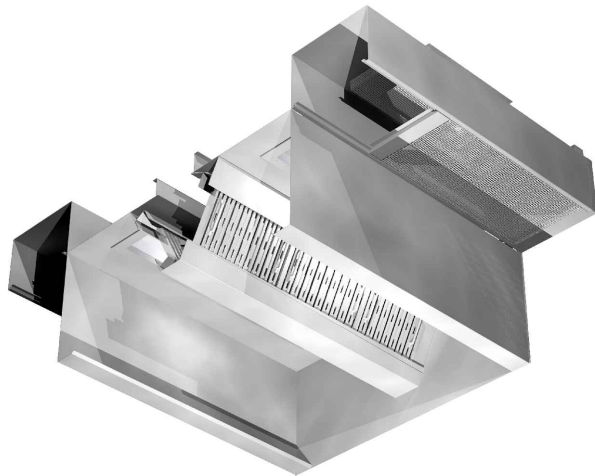
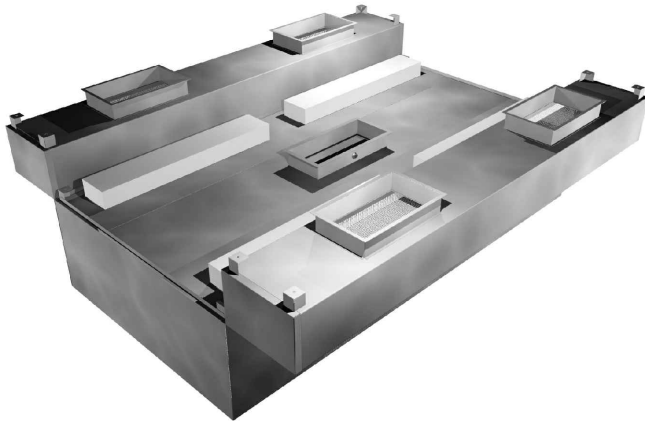

General Specifications

Furnish CADDY **AirSystems** Exhaust Ventilator Model **SHBC-C-II** as shown on the plans and as described in the following specifications.

General

Exhaust ventilator shall be constructed of 18 gauge type 300 series stainless steel. All exposed surfaces to have a #4 finish. Construction to meet all requirements of NFPA 96 and NSF Standard No. 2. To include necessary hanger brackets at front and rear suspending from building overhead structure.

Description

The CADDY **AirSystems** Model "SHBC" Series ventilator is a dry baffle cartridge type and is ETL listed under the standards as set forth in UL710 "Exhaust Hoods for Commercial Cooking Equipment." This ventilator is 95% grease extraction efficient when operated and maintained in accordance with design specifications.

This high efficiency is accomplished by utilizing removable stainless steel baffle cartridges containing a series of horizontal, self-draining baffles. As the air is drawn around the baffles, the grease, dust and lint particles are slung from the air stream by centrifugal force. As the liquefied grease is extracted, it is drained off via a trough into grease collection containers at each end of the ventilator. At the end of the cooking day or at scheduled intervals, the cartridges are removed for cleaning without having to climb up or onto the cooking equipment with the use of a baffle cartridge removal tool. Once removed, the baffle cartridges can be washed in either the dishwasher or soaked and rinsed off in a pot sink. Each baffle cartridge is a maximum of 19-1/2" long. Ventilator can also be equipped with an optional fusible link or thermostatically activated fire damper assembly.

Make-Up Air (Perimeter Down Discharge)

Ventilator shall have air registers along perimeter for down discharge of tempered make-up. Supply volume is 80% or designed to the desired air balance.

Application

Island style cooking applications for use over all types of cooking equipment where integral make-up air is required.

Light Fixtures

All light fixtures shall be pre-wired to a single connection point. Ventilators built in multiple sections to be furnished with junction boxes for ease of field connection by the electrical trades. Light bulbs furnished and installed by the Kitchen Equipment Contractor.

Exhaust Fans

Exhaust fans are to be provided and installed by others in compliance with local codes. **Fans should be induced draft, squirrel cage design, equipped with backward inclined blades.**

Fire Protection

NFPA 96 and local codes require a fire extinguishing system for protection of the duct collar and plenum of all ventilators, as well as for the protection of various cooking appliances such as deep fat fryers, griddles, ranges, and broilers, which may be a source of ignition of grease. Consult factory and local fire officials for exact requirements. UL Listed fire protection systems may be pre-piped by Caddy at the time of manufacture, assuring concealment of piping and detectors.

Approvals

Ventilator shall be ETL Listed, listed by NSF and be in accordance with all of the recommendations set forth by NFPA 96. Filters tested to ASTM Standard F2519-05 by independent third party. All ventilators must meet all applicable codes.





MODEL:

SHBC-C-II---

ADD THE OVERALL LENGTH (IN INCHES) OF THE VENTILATOR AFTER MODEL DESIGNATION

DAMPER TYPE
ND - NO DAMPER
FL - FUSIBLE LINK
T - THERMOSTAT

ADD THE OVERALL WIDTH (IN INCHES) OF THE VENTILATOR AFTER MODEL DESIGNATION

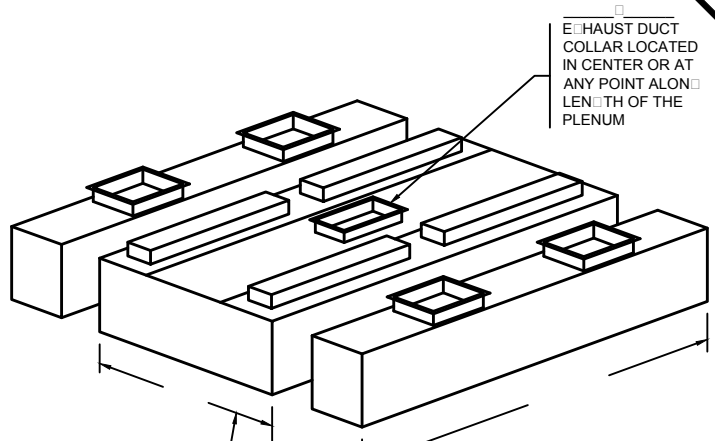

DIMENSION VARIES WITH DEPTH OF THE EQUIPMENT AND REQUIRED OVERHANG

14'-0" MAX. UNIT LENGTH. FOR GREATER LENGTH, JOIN TWO OR MORE UNITS TOGETHER. ALLOW 6" MIN. OVERHANG AT EACH END. IF CHARBROILER IS AT END, OVERHANG 12"

STANDARD LIGHT FIXTURES
() 100 WATT INCANDESCENT
() RECESSED INCANDESCENT
() RECESSED FLUORESCENT
(IF RECESSED FLUORESCENT SPECIFY SIZE)

CONSULT FACTORY FOR NON-STANDARD HEIGHTS

22" MIN. FRONT OVERHANG

6" MIN. SIDE OVERHANG (12" MIN. SIDE OVERHANG FOR CHARBROILER)

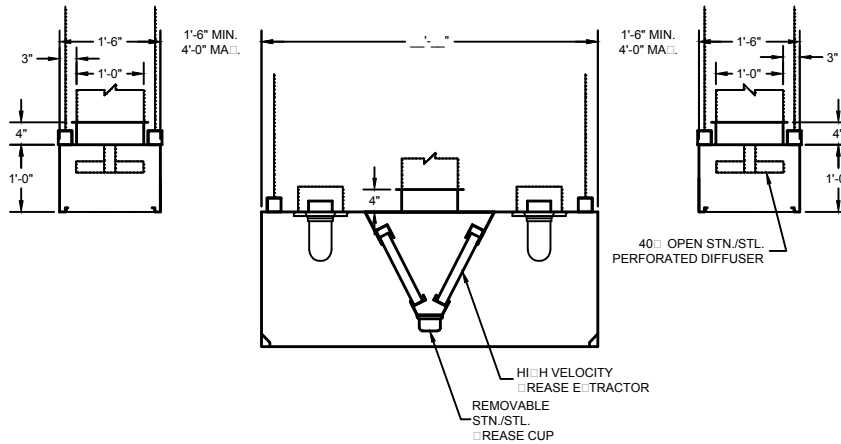

- ITEM # _____
- EST. WEIGHT _____
- LENGTH _____
- WIDTH _____
- HEIGHT _____
- EXHAUST-CFM _____
- DUCT SIZE _____
- S.P. _____

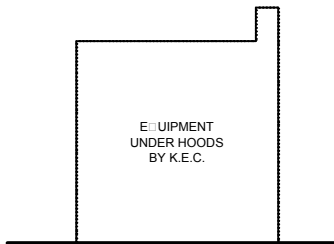

DRAWINGS NOT TO SCALE

ENGINEERING DATA

Ventilator Length

Maximum ventilator length in a single section is 14'-0". For lengths greater than 14'-0", join two or more sections. Verify access conditions into building and kitchen space prior to length selection.

Ventilator Hanging Weight

Wt./lineal ft. Lbs. 105

NOTE: Refer to CADDY AirSystems

Master Engineering Data Sheet in engineering data section for determining light, medium, and heavy duty cooking equipment, C.F.M. requirements (exhaust and supply), duct collar sizes and static pressure requirements.

Electrical Requirements

Light fixtures to be powered by a 120/1/60 circuit.

Mechanical Requirements

The volume of exhaust required is a function of the type of cooking equipment served by the ventilator, and the type and volume of product cooked. Refer to the CADDY AirSystems Master Engineering Data Chart to determine exhaust volume, duct collar sizes, static pressure drop.



Model SHBC-BK-I Baffle Cartridge Ventilator

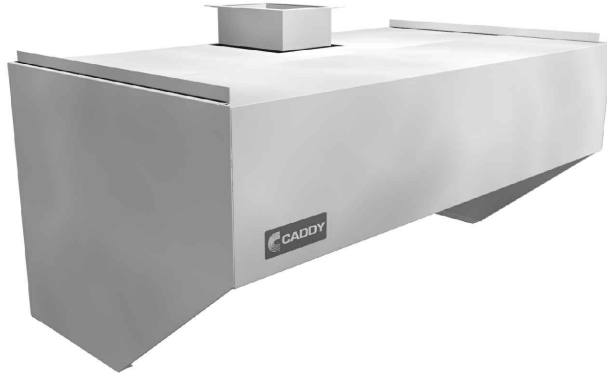

General Specifications

Furnish CADDY *AirSystems* Exhaust Ventilator Model **SHBC-BK-W** as shown on the plans and as described in the following specifications.

General

Exhaust ventilator shall be constructed of 18 gauge type 300 series stainless steel. All exposed surfaces to have a #4 finish. Construction to meet all requirements of NFPA 96 and NSF Standard No. 2. To include necessary hanger brackets at front and rear suspending from building overhead structure.

Description

The CADDY *AirSystems* Model "SHBC" Series ventilator is a dry baffle cartridge type and is ETL listed under the standards as set forth in UL710 "Exhaust Hoods for Commercial Cooking Equipment." This ventilator is 95% grease extraction efficient when operated and maintained in accordance with design specifications. This high efficiency is accomplished by utilizing removable stainless steel baffle cartridges containing a series of horizontal, self-draining baffles. As the air is drawn around the baffles, the grease, dust and lint particles are slung from the air stream by centrifugal force. As the liquefied grease is extracted, it is drained off via a trough into grease collection containers at each end of the ventilator. At the end of the cooking day or at scheduled intervals, the cartridges are removed for cleaning without having to climb up or onto the cooking equipment with the use of a baffle cartridge removal tool. Once removed, the baffle cartridges can be washed in either the dishwasher or soaked and rinsed off in a pot sink. Each baffle cartridge is a maximum of 19-1/2" long. Ventilator can also be equipped with an optional fusible link or thermostatically activated fire damper assembly.

Application

Eyebrow style for direct mounting to roast, bake, reel and pizza ovens.

Light Fixtures

All light fixtures shall be pre-wired to a single connection point. Ventilators built in multiple sections to be furnished with junction boxes for ease of field connection by the electrical trades. Light bulbs furnished and installed by the Kitchen Equipment Contractor.

Exhaust Fans

Exhaust fans are to be provided and installed by others in compliance with local codes. **Fans should be induced draft, squirrel cage design, equipped with backward inclined blades.**

Fire Protection

NFPA 96 and local codes require a fire extinguishing system for protection of the duct collar and plenum of all ventilators, as well as for the protection of various cooking appliances such as deep fat fryers, griddles, ranges, and broilers, which may be a source of ignition of grease. Consult factory and local fire officials for exact requirements. UL Listed fire protection systems may be pre-piped by Caddy at the time of manufacture, assuring concealment of piping and detectors.

Approvals

Ventilator shall be ETL Listed, listed by NSF and be in accordance with all of the recommendations set forth by NFPA 96. Filters tested to ASTM Standard F2519-05 by independent third party. All ventilators must meet all applicable codes.

CADDY CORPORATION
509 Sharptown Road P.O. Box 345
Bridgeport, NJ 08014-0345
Tel: 856-467-4222 Fax: 856-467-5511
internet: www.caddycorp.com



MODEL:

SHBC-BK- I - [] - [] - []

ADD THE OVERALL LENGTH (IN INCHES) OF THE VENTILATOR AFTER MODEL DESIGNATION

DAMPER TYPE
ND - NO DAMPER
FL - FUSIBLE LINK
T - THERMOSTAT

ADD THE OVERALL WIDTH (IN INCHES) OF THE VENTILATOR AFTER MODEL DESIGNATION

STANDARD LIGHT FIXTURES
() 100 WATT INCANDESCENT
() RECESSED INCANDESCENT
() RECESSED FLUORESCENT
(IF RECESSED FLUORESCENT SPECIFY SIZE)

CONSULT FACTORY FOR NON-STANDARD HEIGHTS

ITEM # _____
EST. WEIGHT _____
LENGTH _____
WIDTH _____
HEIGHT _____
EXHAUST-CFM _____
DUCT SIZE _____
S.P. _____

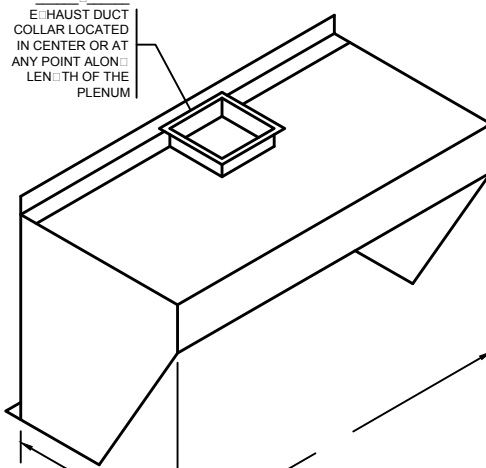

DIMENSION VARIES WITH DEPTH OF THE EQUIPMENT AND REQUIRED OVERHANG

14'-0" MAX. UNIT LENGTH. FOR GREATER LENGTH, JOIN TWO OR MORE UNITS TOGETHER. ALLOW 6" MIN. OVERHANG AT EACH END. IF CHARBROILER IS AT END, OVERHANG 12"

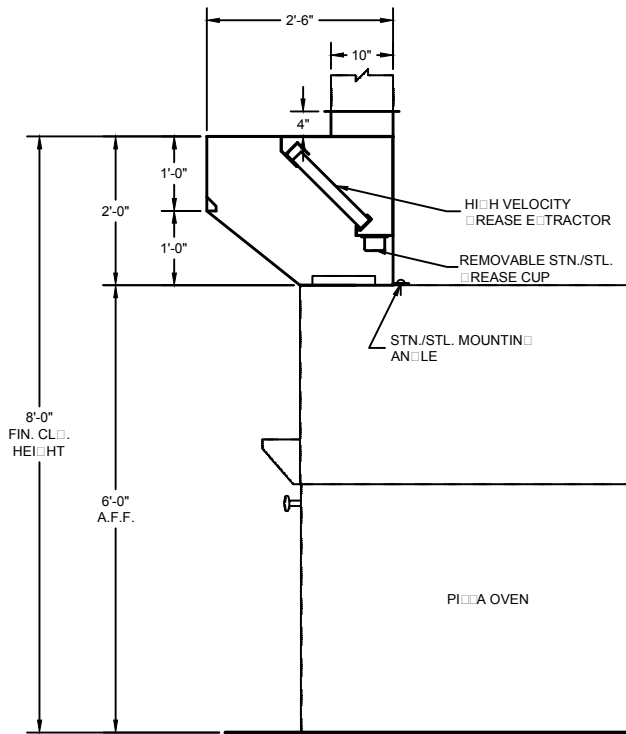

SECTION

DRAWINGS NOT TO SCALE

ENGINEERING DATA

Ventilator Length

Maximum ventilator length in a single section is 14'-0". For lengths greater than 14'-0", join two or more sections. Verify access conditions into building and kitchen space prior to length selection.

Ventilator Hanging Weight

Wt./lineal ft. Lbs. 65

NOTE: Refer to CADDY AirSystems

Master Engineering Data Sheet in engineering data section for determining light, medium, and heavy duty cooking equipment, C.F.M. requirements (exhaust and supply), duct collar sizes and static pressure requirements.

Electrical Requirements

Light fixtures to be powered by a 120/1/60 circuit.

Mechanical Requirements

The volume of exhaust required is a function of the type of cooking equipment served by the ventilator, and the type and volume of product cooked. Refer to the CADDY AirSystems Master Engineering Data Chart to determine exhaust volume, duct collar sizes, static pressure drop.



CADDY Air Systems

Model SHBC-BK-W Baffle Cartridge Ventilator

ITEM NO:

PROJECT:

LOCATION:

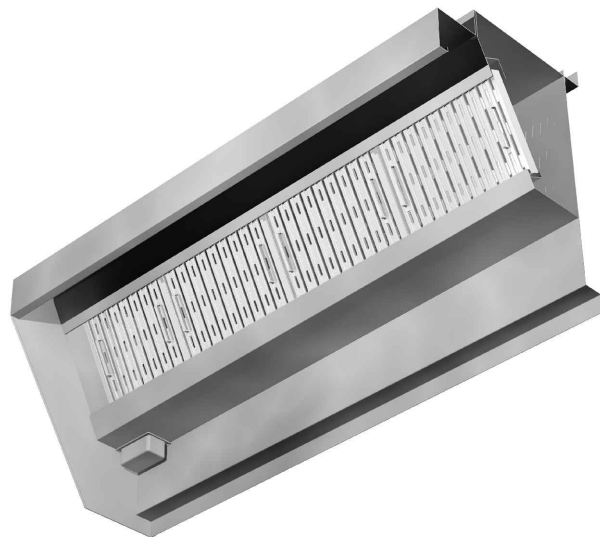

General Specifications

Furnish CADDY *AirSystems* Exhaust Ventilator Model **SHBC-BK-W** as shown on the plans and as described in the following specifications.

General

Exhaust ventilator shall be constructed of 18 gauge type 300 series stainless steel. All exposed surfaces to have a #4 finish. Construction to meet all requirements of NFPA 96 and NSF Standard No. 2. To include necessary hanger brackets at front and rear suspending from building overhead structure.

Description

The CADDY *AirSystems* Model "SHBC" Series ventilator is a dry baffle cartridge type and is ETL listed under the standards as set forth in UL710 "Exhaust Hoods for Commercial Cooking Equipment." This ventilator is 95% grease extraction efficient when operated and maintained in accordance with design specifications. This high efficiency is accomplished by utilizing removable stainless steel baffle cartridges containing a series of horizontal, self-draining baffles. As the air is drawn around the baffles, the grease, dust and lint particles are slung from the air stream by centrifugal force. As the liquefied grease is extracted, it is drained off via a trough into grease collection containers at each end of the ventilator. At the end of the cooking day or at scheduled intervals, the cartridges are removed for cleaning without having to climb up or onto the cooking equipment with the use of a baffle cartridge removal tool. Once removed, the baffle cartridges can be washed in either the dishwasher or soaked and rinsed off in a pot sink. Each baffle cartridge is a maximum of 19-1/2" long. Ventilator can also be equipped with an optional fusible link or thermostatically activated fire damper assembly.

Application

Backshelf style for use over all types of cooking equipment 36" high or less. The shelf of the ventilator shall serve as a plate or pan storage area.

Light Fixtures

All light fixtures shall be pre-wired to a single connection point. Ventilators built in multiple sections to be furnished with junction boxes for ease of field connection by the electrical trades. Light bulbs furnished and installed by the Kitchen Equipment Contractor.

Exhaust Fans

Exhaust fans are to be provided and installed by others in compliance with local codes. **Fans should be induced draft, squirrel cage design, equipped with backward inclined blades.**

Fire Protection

NFPA 96 and local codes require a fire extinguishing system for protection of the duct collar and plenum of all ventilators, as well as for the protection of various cooking appliances such as deep fat fryers, griddles, ranges, and broilers, which may be a source of ignition of grease. Consult factory and local fire officials for exact requirements. UL Listed fire protection systems may be pre-piped by Caddy at the time of manufacture, assuring concealment of piping and detectors.

Approvals

Ventilator shall be ETL Listed, listed by NSF and be in accordance with all of the recommendations set forth by NFPA 96. Filters tested to ASTM Standard F2519-05 by independent third party. All ventilators must meet all applicable codes.

CADDY CORPORATION
509 Sharptown Road P.O. Box 345
Bridgeport, NJ 08014-0345
Tel: 856-467-4222 Fax: 856-467-5511
internet: www.caddycorp.com



MODEL:

SHBC-BK-W- - -

ADD THE OVERALL LENGTH (IN INCHES) OF THE VENTILATOR AFTER MODEL DESIGNATION

DAMPER TYPE
ND - NO DAMPER
FL - FUSIBLE LINK
T - THERMOSTAT

ADD THE OVERALL WIDTH (IN INCHES) OF THE VENTILATOR AFTER MODEL DESIGNATION

STANDARD LIGHT FIXTURES
() 100 WATT INCANDESCENT
() RECESSED INCANDESCENT
() RECESSED FLUORESCENT
(IF RECESSED FLUORESCENT SPECIFY SIZE)

CONSULT FACTORY FOR NON-STANDARD HEIGHTS

ITEM # _____
EST. WEIGHT _____
LENGTH _____
WIDTH _____
HEIGHT _____
EXHAUST-CFM _____
DUCT SIZE _____
S.P. _____

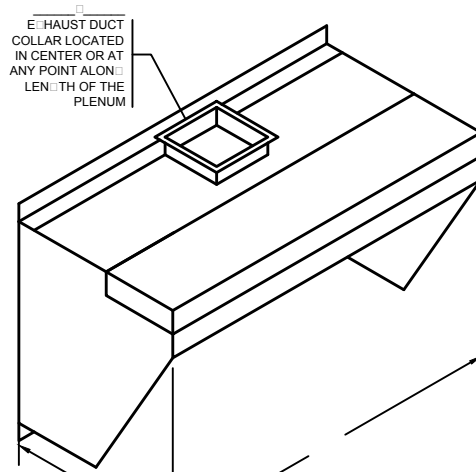

EXHAUST DUCT COLLAR LOCATED IN CENTER OR AT ANY POINT ALONG LENGTH OF THE PLENUM

DIMENSION VARIES WITH DEPTH OF THE EQUIPMENT AND REQUIRED OVERHANG

14'-0" MAX. UNIT LENGTH. FOR GREATER LENGTH, JOIN TWO OR MORE UNITS TOGETHER. ALLOW 6" MIN. OVERHANG AT EACH END. IF CHARBROILER IS AT END, OVERHANG 12"

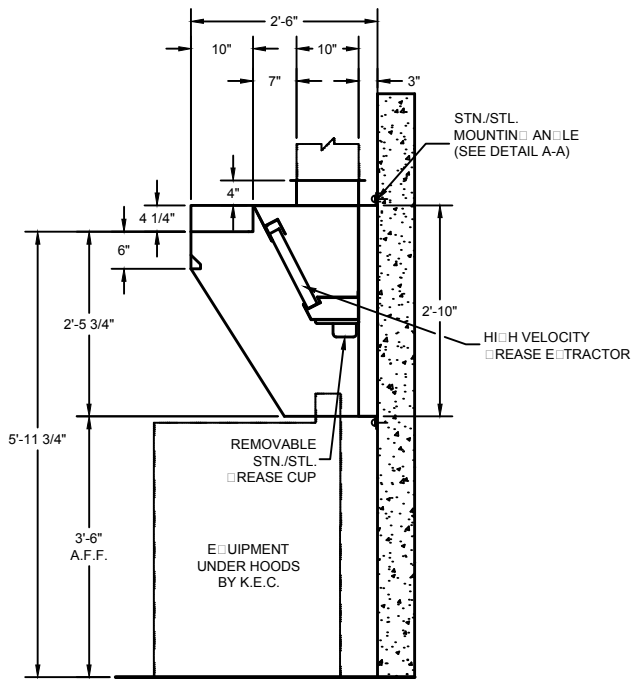

SECTION

DRAWINGS NOT TO SCALE

ENGINEERING DATA

Ventilator Length

Maximum ventilator length in a single section is 14'-0". For lengths greater than 14'-0", join two or more sections. Verify access conditions into building and kitchen space prior to length selection.

Ventilator Hanging Weight

Wt./lineal ft. Lbs. 65

NOTE: Refer to **CADDY AirSystems**

Master Engineering Data Sheet in engineering data section for determining light, medium, and heavy duty cooking equipment, C.F.M. requirements (exhaust and supply), duct collar sizes and static pressure requirements.

Electrical Requirements

Light fixtures to be powered by a 120/1/60 circuit.

Mechanical Requirements

The volume of exhaust required is a function of the type of cooking equipment served by the ventilator, and the type and volume of product cooked. Refer to the **CADDY AirSystems** Master Engineering Data Chart to determine exhaust volume, duct collar sizes, static pressure drop.



CADDY Air Systems

Options & Accessories

Lighting Options:

Multiple lighting options are available:

Dome Lights:
Incandescent
or LED



Recessed
12" x 12"
Incandescent

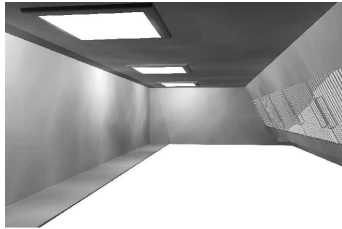

Recessed
24", 36" or 48"
Fluorescent
or LED

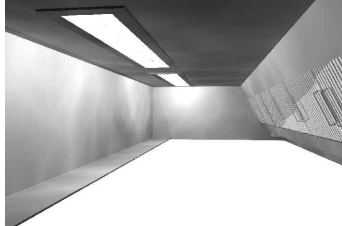

Recessed
10" x 10" LED
Fixtures

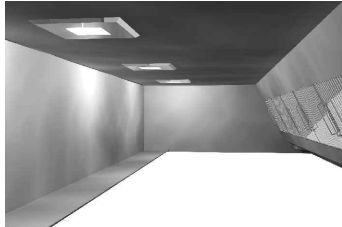

All fixtures are vapor proof and UL Approved.

Exhaust Collars:

- Factory Mounted: Collars are fully welded to the exhaust plenum and include a 1 inch flange.
- Shipped Loose: exhausts openings can be cut on site when exact locations are not known.
- Shape: Rectangular or Round to accommodate ductwork.
- Location: Top, back, or side.

Supply Collars:

- Shipped Loose
- Shape: Rectangular or Round
- Number: Variable

Tapered Hood: Available to accommodate low ceiling applications.



Enclosure Panels:



Stainless Steel Wall Flashing:



 **CADDY CORPORATION**
509 Sharptown Road P.O. Box 345
Bridgeport, NJ 08014-0345
Tel: 856-467-4222 Fax: 856-467-5511
internet: www.caddycorp.com



CADDY CORPORATION

Food Service Equipment

Air Systems

Commercial Kitchen Exhaust Systems

Model SHBCU
Ultra-Violet Style

CADDY Air Systems

Model SHBCU-C-W Ultra-Violet Ventilator

ITEM NO:

PROJECT:

LOCATION:

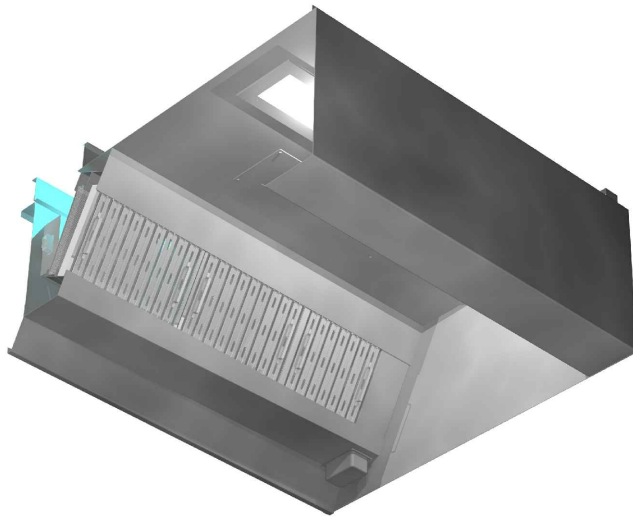
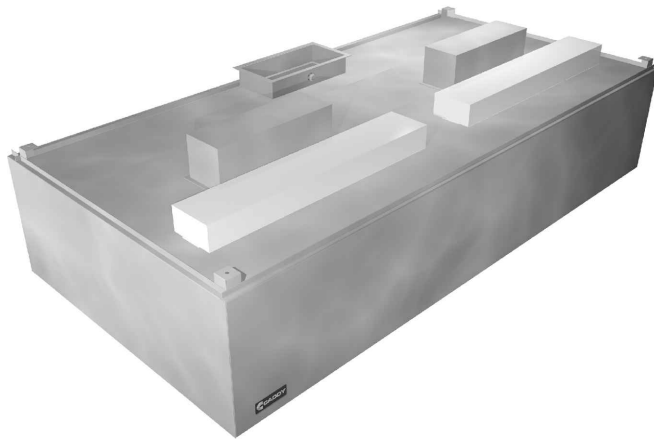

General Specifications

Furnish CADDY *AirSystems* Exhaust Hood Model **SHBCU-C-W** as shown on the plans and as described in the following specifications.

General

Exhaust ventilator shall be constructed of 18 gauge type 300 series stainless steel. All exposed surfaces to have a number 4 finish. Construction to meet all requirements of NFPA 96 and NSF Standard 2. To include necessary hanger brackets at front and rear for suspending from building overhead structure.

Description

The CADDY *AirSystems* Model "SHBCU" Series ventilator is an Ultra-Violet type and is ETL Listed under the standards as set forth in UL710 "Exhaust Hoods for Commercial Cooking Equipment". This ventilator uses Ultra-Violet light source technology for cleaning the inside of the hood.

The ventilator shall be complete with a control panel with a ON/OFF switch, alarm reset button, alarm buzzer, and status lights to indicate power on, maintenance required, and light safety shut-down. This ventilator is 95% grease extraction efficient when operated and maintained in accordance with design specifications. This high efficiency is accomplished by utilizing removable stainless steel baffle cartridges containing a series of horizontal, self-draining baffles. As the air is drawn around the baffles, the grease, dust and lint particles are slung from the airstream by centrifugal force. As the liquefied grease is extracted, it is drained off via a trough into grease collection containers at each end of the ventilator. At the end of the cooking day or at scheduled intervals, the baffle cartridges are removed for cleaning without having to climb up or onto the cooking equipment. Once removed, the baffle cartridges can be washed either in a dishwasher or soaked and rinsed off in a pot sink. Each baffle cartridge is a maximum of 19-1/2" long. The ventilator can be equipped with an optional fusible link type fire damper assembly.

Application

Wall mounted exhaust-only canopy style for use over all types of cooking equipment.

Light Fixtures

All light fixtures shall be pre-wired to a single connection point. Ventilators built in multiple sections to be furnished with junction boxes for ease of field connection by the Electrical Trades. Light bulbs furnished and installed by the Kitchen Equipment Contractor.

Exhaust Fans/Make-Up Air Units

Exhaust fans are to be provided and installed by others in compliance with local codes. Fans should be induced draft, squirrel cage design, equipped with backward inclined blades.

Fire Protection

NFPA Standard 96 and local codes require a fire extinguishing system for protection of the duct collar and plenum of all ventilators, as well as for the protection of various cooking appliances such as deep fat fryers, griddles, ranges, and broilers, which may be a source of ignition of grease. Consult factory and local fire officials for exact requirements. UL Listed fire protection systems may be pre-piped by Caddy at the time of manufacture, assuring concealment of piping and detectors.

Approvals

Ventilator shall be ETL listed, listed by NSF, and be in accordance with all of the recommendations set forth by NFPA's Standard 96. Filters tested to ASTM Standard F2519-05 by independent third party. All ventilators must meet all applicable codes.





MODEL:

SHBCU-C-W - - -

ADD THE OVERALL LENGTH (IN INCHES) OF THE VENTILATOR AFTER MODEL DESIGNATION

DAMPER TYPE
ND - NO DAMPER
FL - FUSIBLE LINK
T - THERMOSTAT

ADD THE OVERALL WIDTH (IN INCHES) OF THE VENTILATOR AFTER MODEL DESIGNATION

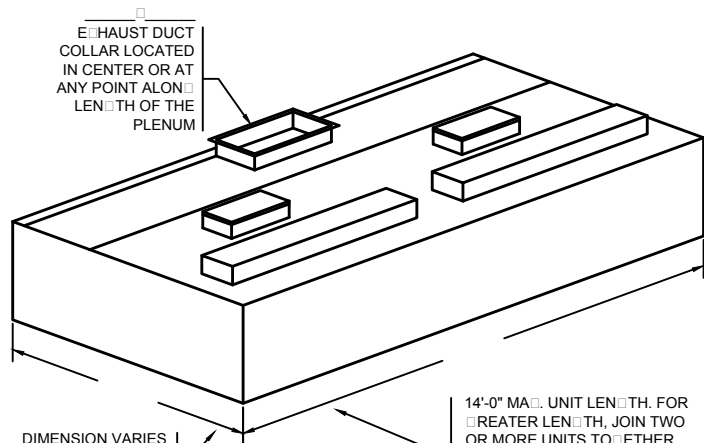

DIMENSION VARIES WITH DEPTH OF THE EQUIPMENT AND REQUIRED OVERHANG

14'-0" MAX. UNIT LENGTH. FOR GREATER LENGTH, JOIN TWO OR MORE UNITS TOGETHER. ALLOW 6" MIN. OVERHANG AT EACH END. IF CHARBROILER IS AT END, OVERHANG 12"

STANDARD LIGHT FIXTURES
() 100 WATT INCANDESCENT
() RECESSED INCANDESCENT
() RECESSED FLUORESCENT (IF RECESSED FLUORESCENT SPECIFY SIZE)

CONSULT FACTORY FOR NON-STANDARD HEIGHTS

12" MIN. FRONT OVERHANG

6" MIN. SIDE OVERHANG (12" MIN. SIDE OVERHANG FOR CHARBROILER)

ITEM # _____
EST. WEIGHT _____
LENGTH _____
WIDTH _____
HEIGHT _____
EXHAUST-CFM _____
DUCT SIZE _____
S.P. _____

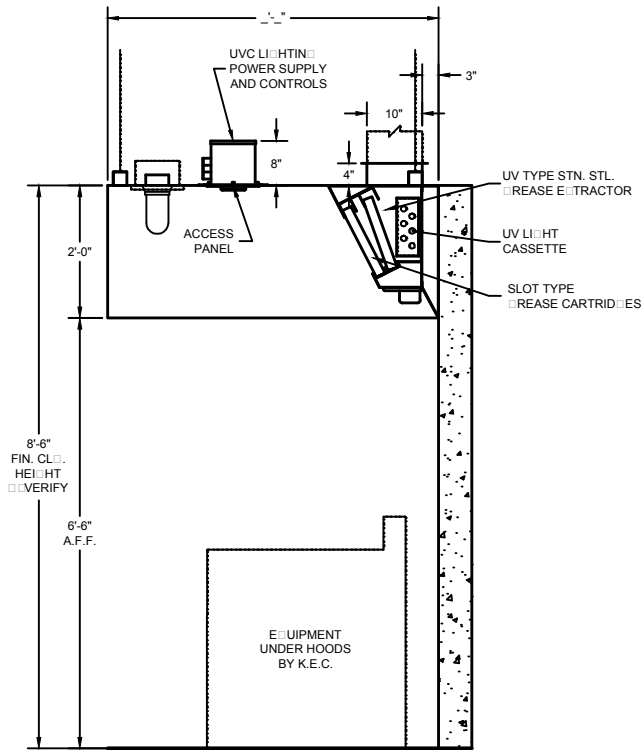

SECTION

DRAWINGS NOT TO SCALE

ENGINEERING DATA

Ventilator Length

Maximum ventilator length in a single section is 14'-0". For lengths greater than 14'-0", join two or more sections. Verify access conditions into building and kitchen space prior to length selection.

Ventilator Hanging Weight

Wt./lineal ft. Lbs. 90

Electrical Requirements

Light fixtures to be powered by a 120/1/60 circuit. UV Ballast boxes require (1) 120/1/60 15 Amp circuit per ventilator. UV Control Panel requires a 120/1/60 15 Amp circuit.

Mechanical Requirements

The volume of exhaust required is a function of the type of cooking equipment served by the ventilator, and the type and volume of product cooked.

NOTE: Refer to **CADDY AirSystems**

Master Engineering Data Sheet in engineering data section for determining light, medium, and heavy duty cooking equipment, C.F.M. requirements (exhaust and supply), duct collar sizes and static pressure requirements.



CADDY Air Systems

Model SHBCU-C-W-PA Ultra-Violet Ventilator

ITEM NO:

PROJECT:

LOCATION:

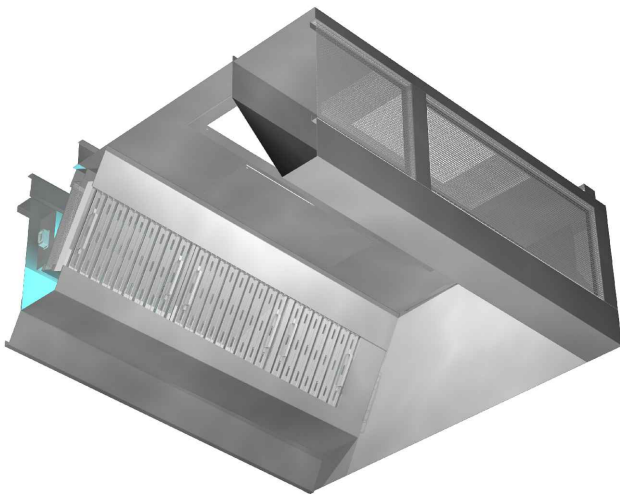
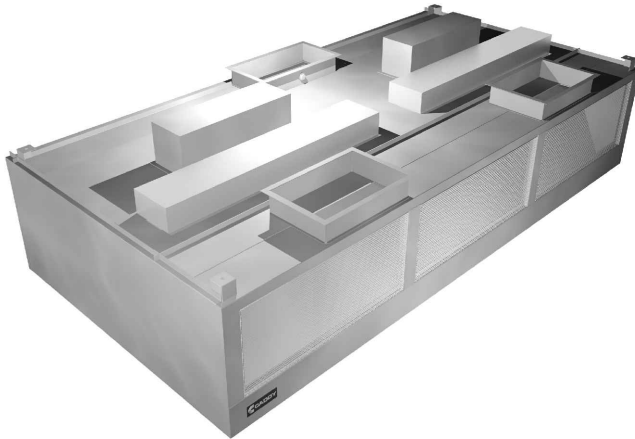

General Specifications

Furnish CADDY Air Systems Exhaust Hood Model SHBCU-C-W-PA as shown on the plans and as described in the following specifications.

General

Exhaust ventilator shall be constructed of 18 gauge type 300 series stainless steel. All exposed surfaces to have a number 4 finish. Construction to meet all requirements of NFPA 96 and NSF Standard 2. To include necessary hanger brackets at front and rear for suspending from building overhead structure.

Description

The CADDY Air Systems Model "SHBCU" Series ventilator is an Ultra-Violet type and is ETL Listed under the standards as set forth in UL710 "Exhaust Hoods for Commercial Cooking Equipment". This ventilator uses Ultra-Violet light source technology for cleaning the inside of the hood. The ventilator shall be complete with a control panel with a ON/OFF switch, alarm reset button, alarm buzzer, and status lights to indicate power on, maintenance required, and light safety shut-down. This ventilator is 95% grease extraction efficient when operated and maintained in accordance with design specifications.

This high efficiency is accomplished by utilizing removable stainless steel baffle cartridges containing a series of horizontal, self-draining baffles. As the air is drawn around the baffles, the grease, dust and lint particles are slung from the airstream by centrifugal force. As the liquefied grease is extracted, it is drained off via a trough into grease collection containers at each end of the ventilator. At the end of the cooking day or at scheduled intervals, the baffle cartridges are removed for cleaning without having to climb up or onto the cooking equipment. Once removed, the baffle cartridges can be washed either in a dishwasher or soaked and rinsed off in a pot sink. Each baffle cartridge is a maximum of 19-1/2" long. The ventilator can be equipped with an optional fusible link type fire damper assembly.

Make-Up Air (Front Face Discharge)

Ventilator shall have 40% open stainless steel perforated screens along front face for discharge of tempered make-up air. Supply volume is 80% or designed to the desired air balance.

Application

Wall mounted exhaust-only canopy style for use over all types of cooking equipment.

Light Fixtures

All light fixtures shall be pre-wired to a single connection point. Ventilators built in multiple sections to be furnished with junction boxes for ease of field connection by the Electrical Trades. Light bulbs furnished and installed by the Kitchen Equipment Contractor.

Exhaust Fans/Make-Up Air Units

Exhaust fans are to be provided and installed by others in compliance with local codes. Fans should be induced draft, squirrel cage design, equipped with backward inclined blades.

Fire Protection

NFPA Standard 96 and local codes require a fire extinguishing system for protection of the duct collar and plenum of all ventilators, as well as for the protection of various cooking appliances such as deep fat fryers, griddles, ranges, and broilers, which may be a source of ignition of grease. Consult factory and local fire officials for exact requirements. UL Listed fire protection systems may be pre-piped by Caddy at the time of manufacture, assuring concealment of piping and detectors.

Approvals

Ventilator shall be ETL listed, listed by NSF, and be in accordance with all of the recommendations set forth by NFPA's Standard 96. Filters tested to ASTM Standard F2519-05 by independent third party. All ventilators must meet all applicable codes.





MODEL:

SHBCU-C-W-PA---

ADD THE OVERALL LENGTH (IN INCHES) OF THE VENTILATOR AFTER MODEL DESIGNATION

DAMPER TYPE
ND - NO DAMPER
FL - FUSIBLE LINK
T - THERMOSTAT

ADD THE OVERALL WIDTH (IN INCHES) OF THE VENTILATOR AFTER MODEL DESIGNATION

EXHAUST DUCT COLLAR LOCATED IN CENTER OR AT ANY POINT ALONG LENGTH OF THE PLENUM

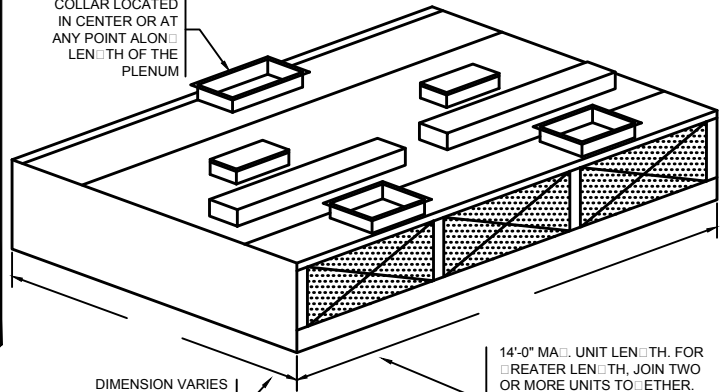

DIMENSION VARIES WITH DEPTH OF THE EQUIPMENT AND REQUIRED OVERHANG

14'-0" MAX. UNIT LENGTH. FOR GREATER LENGTH, JOIN TWO OR MORE UNITS TOGETHER. ALLOW 6" MIN. OVERHANG AT EACH END. IF CHARBROILER IS AT END, OVERHANG 12"

STANDARD LIGHT FIXTURES
() 100 WATT INCANDESCENT
() RECESSED INCANDESCENT
() RECESSED FLUORESCENT
(IF RECESSED FLUORESCENT SPECIFY SIZE)

CONSULT FACTORY FOR NON-STANDARD HEIGHTS
12" MIN. FRONT OVERHANG
6" MIN. SIDE OVERHANG (12" MIN. SIDE OVERHANG FOR CHARBROILER)

ITEM _____
EST. WEIGHT _____
LENGTH _____
WIDTH _____
HEIGHT _____
EXHAUST-CFM _____
DUCT SIZE _____
S.P. _____

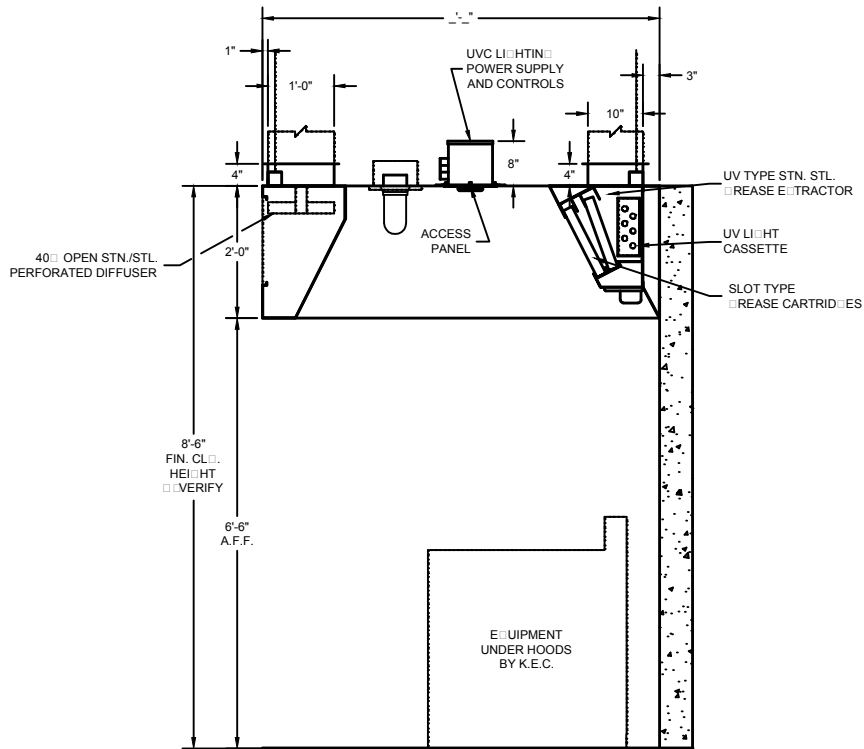

SECTION

DRAWINGS NOT TO SCALE

ENGINEERING DATA

Ventilator Length

Maximum ventilator length in a single section is 14'-0". For lengths greater than 14'-0", join two or more sections. Verify access conditions into building and kitchen space prior to length selection.

Ventilator Hanging Weight

Wt./lineal ft. Lbs. 105

NOTE: Refer to CADDY AirSystems

Master Engineering Data Sheet in engineering data section for determining light, medium, and heavy duty cooking equipment, C.F.M. requirements (exhaust and supply), duct collar sizes and static pressure requirements.

Electrical Requirements

Light fixtures to be powered by a 120/1/60 circuit. UV Ballast boxes require (1) 120/1/60 15 Amp circuit per ventilator. UV Control Panel requires a 120/1/60 15 Amp circuit.

Mechanical Requirements

The volume of exhaust required is a function of the type of cooking equipment served by the ventilator, and the type and volume of product cooked.



CADDY Air Systems

ITEM NO:

Model SHBCU-C-W Ultra-Violet Ventilator With Ceiling Supply Plenum

PROJECT:

LOCATION:

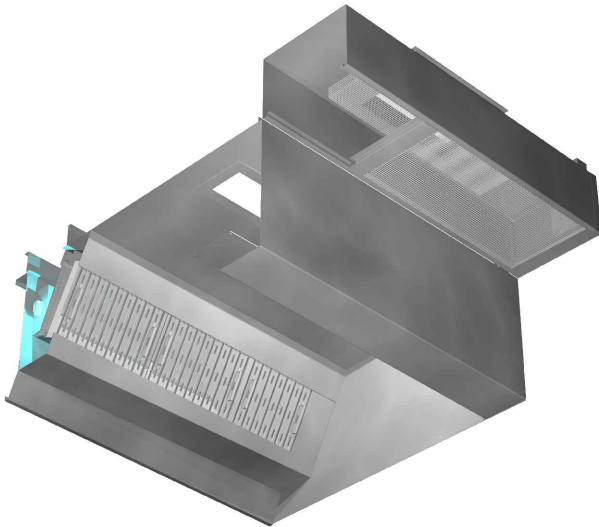
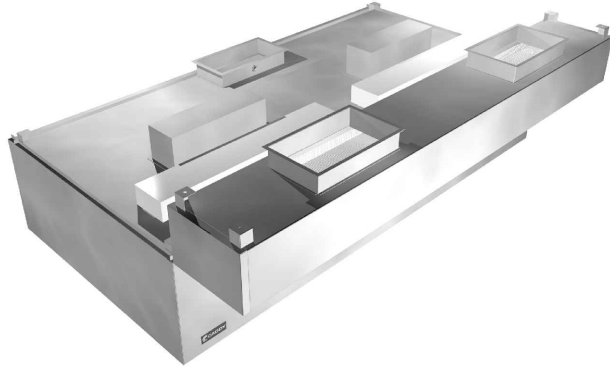

General Specifications

Furnish CADDY *AirSystems* Exhaust Hood Model **SHBCU-C-W** as shown on the plans and as described in the following specifications.

General

Exhaust ventilator shall be constructed of 18 gauge type 300 series stainless steel. All exposed surfaces to have a number 4 finish. Construction to meet all requirements of NFPA 96 and NSF Standard 2. To include necessary hanger brackets at front and rear for suspending from building overhead structure.

Description

The CADDY *AirSystems* Model "SHBCU" Series ventilator is an Ultra-Violet type and is ETL Listed under the standards as set forth in UL710 "Exhaust Hoods for Commercial Cooking Equipment". This ventilator uses Ultra-Violet light source technology for cleaning the inside of the hood. The ventilator shall be complete with a control panel with a ON/OFF switch, alarm reset button, alarm buzzer, and status lights to indicate power on, maintenance required, and light safety shut-down.

This ventilator is 95% grease extraction efficient when operated and maintained in accordance with design specifications. This high efficiency is accomplished by utilizing removable stainless steel baffle cartridges containing a series of horizontal, self-draining baffles. As the air is drawn around the baffles, the grease, dust and lint particles are slung from the airstream by centrifugal force. As the liquefied grease is extracted, it is drained off via a trough into grease collection containers at each end of the ventilator. At the end of the cooking day or at scheduled intervals, the baffle cartridges are removed for cleaning without having to climb up or onto the cooking equipment. Once removed, the baffle cartridges can be washed either in a dishwasher or soaked and rinsed off in a pot sink. Each baffle cartridge is a maximum of 19-1/2" long. The ventilator can be equipped with an optional fusible link type fire damper assembly.

Make-Up Air (Perimeter Down Discharge)

Ventilator shall have air registers along perimeter for down discharge of tempered make-up. Supply volume is 80% or designed to the desired air balance.

Application

Wall mounted exhaust-only canopy style for use over all types of cooking equipment.

Light Fixtures

All light fixtures shall be pre-wired to a single connection point. Ventilators built in multiple sections to be furnished with junction boxes for ease of field connection by the Electrical Trades. Light bulbs furnished and installed by the Kitchen Equipment Contractor.

Exhaust Fans/Make-Up Air Units

Exhaust fans are to be provided and installed by others in compliance with local codes. Fans should be induced draft, squirrel cage design, equipped with backward inclined blades.

Fire Protection

NFPA Standard 96 and local codes require a fire extinguishing system for protection of the duct collar and plenum of all ventilators, as well as for the protection of various cooking appliances such as deep fat fryers, griddles, ranges, and broilers, which may be a source of ignition of grease. Consult factory and local fire officials for exact requirements. UL Listed fire protection systems may be pre-piped by Caddy at the time of manufacture, assuring concealment of piping and detectors.

Approvals

Ventilator shall be ETL listed, listed by NSF, and be in accordance with all of the recommendations set forth by NFPA's Standard 96. Filters tested to ASTM Standard F2519-05 by independent third party. All ventilators must meet all applicable codes.





MODEL:

SHBCU-C-W- [] - [] - []

ADD THE OVERALL LENGTH (IN INCHES) OF THE VENTILATOR AFTER MODEL DESIGNATION

DAMPER TYPE
ND - NO DAMPER
FL - FUSIBLE LINK
T - THERMOSTAT

ADD THE OVERALL WIDTH (IN INCHES) OF THE VENTILATOR AFTER MODEL DESIGNATION

EXHAUST DUCT COLLAR LOCATED IN CENTER OR AT ANY POINT ALONG LENGTH OF THE PLENUM

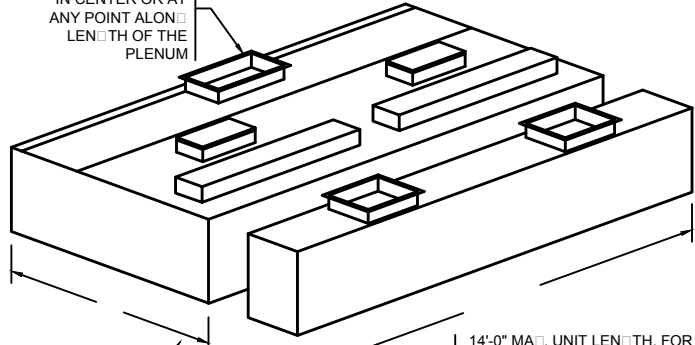

14'-0" MAX. UNIT LENGTH. FOR GREATER LENGTH, JOIN TWO OR MORE UNITS TOGETHER. ALLOW 6" MIN. OVERHANG AT EACH END. IF CHARBROILER IS AT END, OVERHANG 12"

DIMENSION VARIES WITH DEPTH OF THE EQUIPMENT AND REQUIRED OVERHANG

STANDARD LIGHT FIXTURES
() 100 WATT INCANDESCENT
() RECESSED INCANDESCENT
() RECESSED FLUORESCENT (IF RECESSED FLUORESCENT SPECIFY SIZE)

CONSULT FACTORY FOR NON-STANDARD HEIGHTS
22" MIN. FRONT OVERHANG
6" MIN. SIDE OVERHANG (12" MIN. SIDE OVERHANG FOR CHARBROILER)

ITEM #	_____
EST. WEIGHT	_____
LENGTH	_____
WIDTH	_____
HEIGHT	_____
EXHAUST-CFM	_____
DUCT SIZE	_____
S.P.	_____

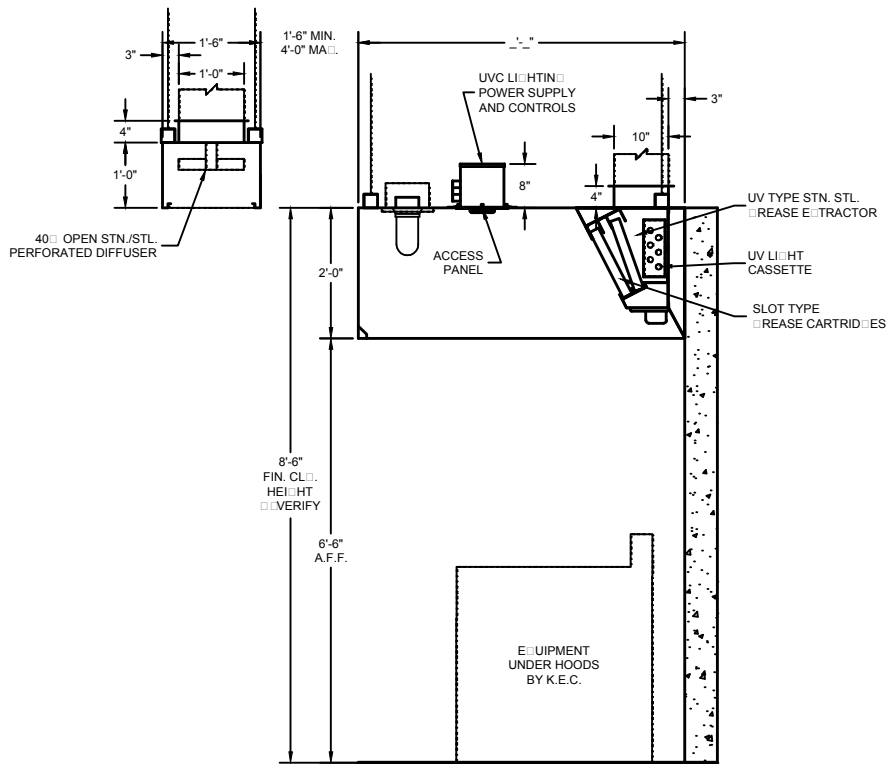

SECTION

DRAWINGS NOT TO SCALE

ENGINEERING DATA

Ventilator Length

Maximum ventilator length in a single section is 14'-0". For lengths greater than 14'-0", join two or more sections. Verify access conditions into building and kitchen space prior to length selection.

Ventilator Hanging Weight

Wt./lineal ft.	Lbs.	105
----------------	------	-----

Electrical Requirements

Light fixtures to be powered by a 120/1/60 circuit. UV Ballast boxes require (1) 120/1/60 15 Amp circuit per ventilator. UV Control Panel requires a 120/1/60 15 Amp circuit.

Mechanical Requirements

The volume of exhaust required is a function of the type of cooking equipment served by the ventilator, and the type and volume of product cooked.

NOTE: Refer to **CADDY AirSystems**

Master Engineering Data Sheet in engineering data section for determining light, medium, and heavy duty cooking equipment, C.F.M. requirements (exhaust and supply), duct collar sizes and static pressure requirements.



CADDY Air Systems

Model SHBCU-C-I Ultra-Violet Ventilator

ITEM NO:

PROJECT:

LOCATION:

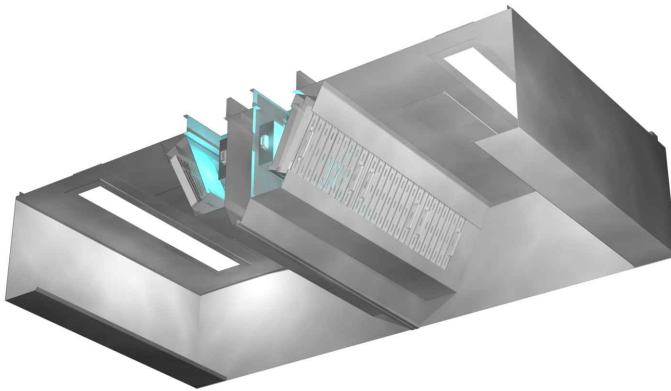
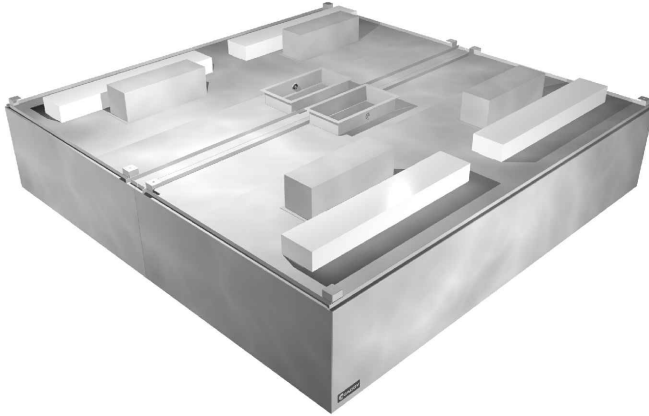

General Specifications

Furnish CADDY *AirSystems* Exhaust Hood Model **SHBCU-C-I** as shown on the plans and as described in the following specifications.

General

Exhaust ventilator shall be constructed of 18 gauge type 300 series stainless steel. All exposed surfaces to have a number 4 finish. Construction to meet all requirements of NFPA 96 and NSF Standard 2. To include necessary hanger brackets at front and rear for suspending from building overhead structure.

Description

The CADDY *AirSystems* Model "SHBCU" Series ventilator is an Ultra-Violet type and is ETL Listed under the standards as set forth in UL710 "Exhaust Hoods for Commercial Cooking Equipment". This ventilator uses Ultra-Violet light source technology for cleaning the inside of the hood. The ventilator shall be complete with a control panel with a ON/OFF switch, alarm reset button, alarm buzzer, and status lights to indicate power on, maintenance required, and light safety shut-down.

This ventilator is 95% grease extraction efficient when operated and maintained in accordance with design specifications. This high efficiency is accomplished by utilizing removable stainless steel baffle cartridges containing a series of horizontal, self-draining baffles. As the air is drawn around the baffles, the grease, dust and lint particles are slung from the airstream by centrifugal force. As the liquefied grease is extracted, it is drained off via a trough into grease collection containers at each end of the ventilator. At the end of the cooking day or at scheduled intervals, the baffle cartridges are removed for cleaning without having to climb up or onto the cooking equipment. Once removed, the baffle cartridges can be washed either in a dishwasher or soaked and rinsed off in a pot sink. Each baffle cartridge is a maximum of 19-1/2" long. The ventilator can be equipped with an optional fusible link type fire damper assembly.

Application

Island mounted exhaust-only canopy style for use over all types of cooking equipment.

Light Fixtures

All light fixtures shall be pre-wired to a single connection point. Ventilators built in multiple sections to be furnished with junction boxes for ease of field connection by the Electrical Trades. Light bulbs furnished and installed by the Kitchen Equipment Contractor.

Exhaust Fans/Make-Up Air Units

Exhaust fans are to be provided and installed by others in compliance with local codes. Fans should be induced draft, squirrel cage design, equipped with backward inclined blades.

Fire Protection

NFPA Standard 96 and local codes require a fire extinguishing system for protection of the duct collar and plenum of all ventilators, as well as for the protection of various cooking appliances such as deep fat fryers, griddles, ranges, and broilers, which may be a source of ignition of grease. Consult factory and local fire officials for exact requirements. UL Listed fire protection systems may be pre-piped by Caddy at the time of manufacture, assuring concealment of piping and detectors.

Approvals

Ventilator shall be ETL listed, listed by NSF, and be in accordance with all of the recommendations set forth by NFPA's Standard 96. Filters tested to ASTM Standard F2519-05 by independent third party. All ventilators must meet all applicable codes.





MODEL:

SHBCU-C-I---

ADD THE OVERALL LENGTH (IN INCHES) OF THE VENTILATOR AFTER MODEL DESIGNATION

DAMPER TYPE
ND - NO DAMPER
FL - FUSIBLE LINK
T - THERMOSTAT

ADD THE OVERALL WIDTH (IN INCHES) OF THE VENTILATOR AFTER MODEL DESIGNATION

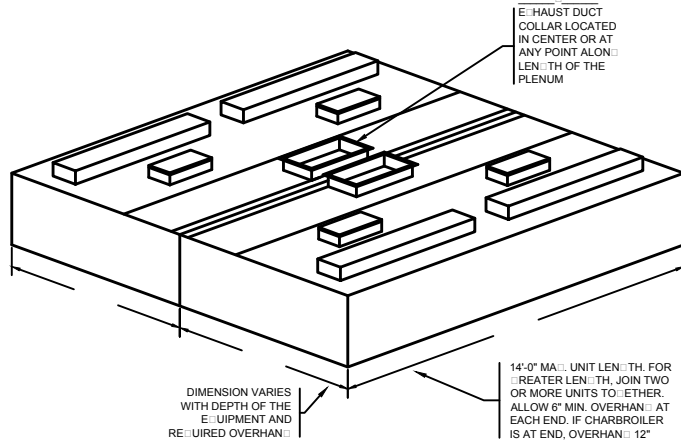

STANDARD LIGHT FIXTURES
() 100 WATT INCANDESCENT
() RECESSED INCANDESCENT
() RECESSED FLUORESCENT (IF RECESSED FLUORESCENT SPECIFY SIZE)

CONSULT FACTORY FOR NON-STANDARD HEIGHTS

12" MIN. FRONT OVERHANG

6" MIN. SIDE OVERHANG (12" MIN. SIDE OVERHANG FOR CHARBROILER)

ITEM #	_____
EST. WEIGHT	_____
LENGTH	_____
WIDTH	_____
HEIGHT	_____
EXHAUST-CFM	_____
DUCT SIZE	_____
S.P.	_____

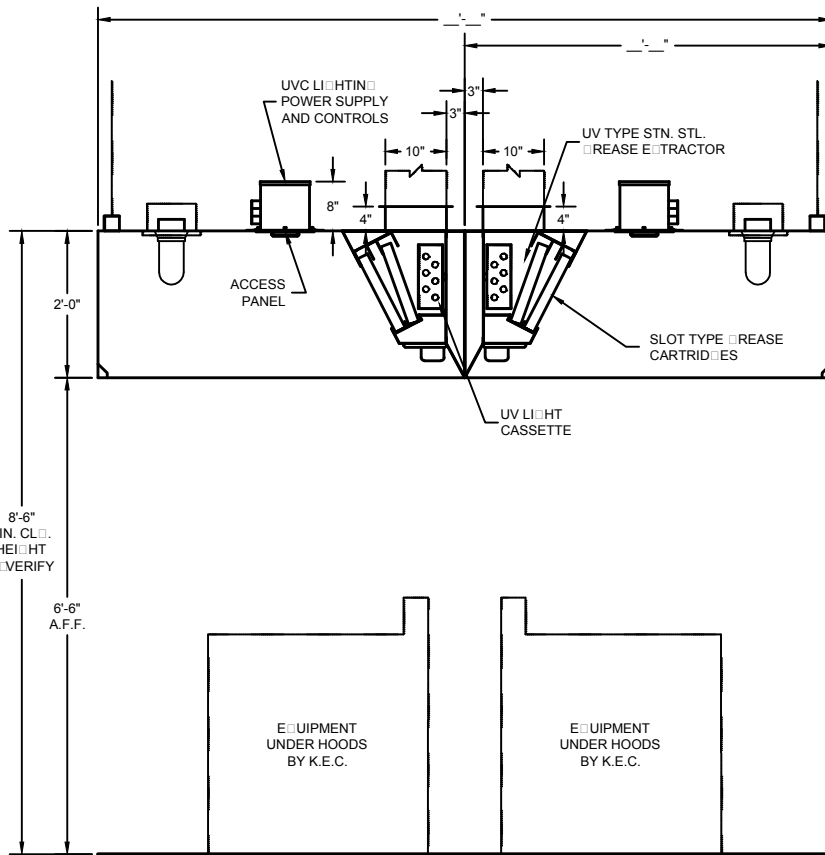

SECTION

DRAWINGS NOT TO SCALE

ENGINEERING DATA

Ventilator Length

Maximum ventilator length in a single section is 14'-0". For lengths greater than 14'-0", join two or more sections. Verify access conditions into building and kitchen space prior to length selection.

Ventilator Hanging Weight

Wt./lineal ft.	Lbs.	105
----------------	------	-----

Electrical Requirements

Light fixtures to be powered by a 120/1/60 circuit. UV Ballast boxes require (1) 120/1/60 15 Amp circuit per ventilator. UV Control Panel requires a 120/1/60 15 Amp circuit.

Mechanical Requirements

The volume of exhaust required is a function of the type of cooking equipment served by the ventilator, and the type and volume of product cooked.

NOTE: Refer to **CADDY AirSystems**

Master Engineering Data Sheet in engineering data section for determining light, medium, and heavy duty cooking equipment, C.F.M. requirements (exhaust and supply), duct collar sizes and static pressure requirements.



CADDY Air Systems

Model SHBCU-C-I-PA Ultra-Violet Ventilator

ITEM NO:

PROJECT:

LOCATION:

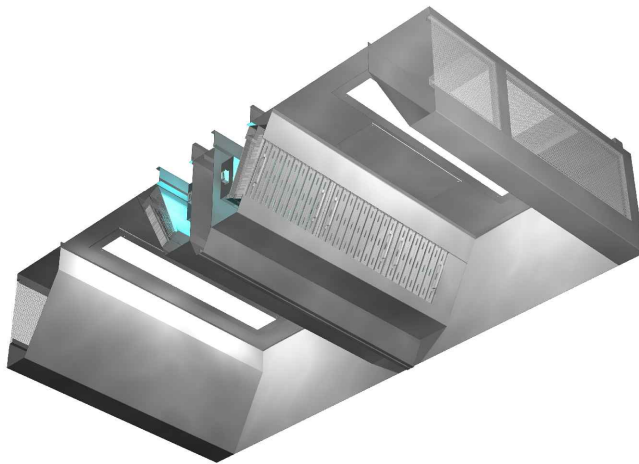
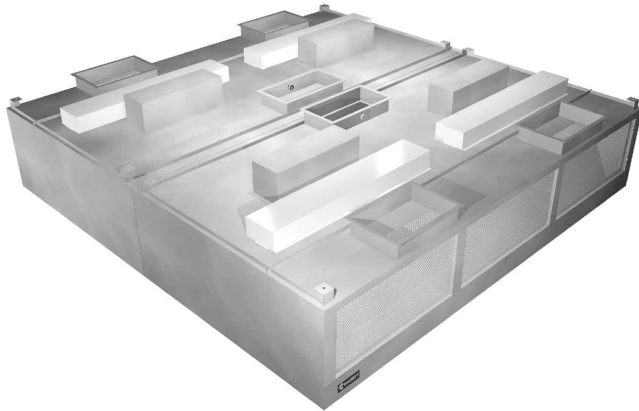

General Specifications

Furnish CADDY *AirSystems* Exhaust Hood Model **SHBCU-C-I-PA** as shown on the plans and as described in the following specifications.

General

Exhaust ventilator shall be constructed of 18 gauge type 300 series stainless steel. All exposed surfaces to have a number 4 finish. Construction to meet all requirements of NFPA 96 and NSF Standard 2. To include necessary hanger brackets at front and rear for suspending from building overhead structure.

Description

The CADDY *AirSystems* Model "SHBCU" Series ventilator is an Ultra-Violet type and is ETL Listed under the standards as set forth in UL710 "Exhaust Hoods for Commercial Cooking Equipment". This ventilator uses Ultra-Violet light source technology for cleaning the inside of the hood. The ventilator shall be complete with a control panel with a ON/OFF switch, alarm reset button, alarm buzzer, and status lights to indicate power on, maintenance required, and light safety shut-down. This ventilator is 95% grease extraction efficient when operated and maintained in accordance with design specifications.

This high efficiency is accomplished by utilizing removable stainless steel baffle cartridges containing a series of horizontal, self-draining baffles. As the air is drawn around the baffles, the grease, dust and lint particles are slung from the airstream by centrifugal force. As the liquefied grease is extracted, it is drained off via a trough into grease collection containers at each end of the ventilator. At the end of the cooking day or at scheduled intervals, the baffle cartridges are removed for cleaning without having to climb up or onto the cooking equipment. Once removed, the baffle cartridges can be washed either in a dishwasher or soaked and rinsed off in a pot sink. Each baffle cartridge is a maximum of 19-1/2" long. The ventilator can be equipped with an optional fusible link type fire damper assembly.

Make-Up Air (Front Face Discharge)

Ventilator shall have 40% open stainless steel perforated screens along front face for discharge of tempered make-up air. Supply volume is 80% or designed to the desired air balance.

Application

Island style cooking applications for use over all types of cooking equipment where integral make-up air is required.

Light Fixtures

All light fixtures shall be pre-wired to a single connection point. Ventilators built in multiple sections to be furnished with junction boxes for ease of field connection by the Electrical Trades. Light bulbs furnished and installed by the Kitchen Equipment Contractor.

Exhaust Fans/Make-Up Air Units

Exhaust fans are to be provided and installed by others in compliance with local codes. Fans should be induced draft, squirrel cage design, equipped with backward inclined blades.

Fire Protection

NFPA Standard 96 and local codes require a fire extinguishing system for protection of the duct collar and plenum of all ventilators, as well as for the protection of various cooking appliances such as deep fat fryers, griddles, ranges, and broilers, which may be a source of ignition of grease. Consult factory and local fire officials for exact requirements. UL Listed fire protection systems may be pre-piped by Caddy at the time of manufacture, assuring concealment of piping and detectors.

Approvals

Ventilator shall be ETL listed, listed by NSF, and be in accordance with all of the recommendations set forth by NFPA's Standard 96. Filters tested to ASTM Standard F2519-05 by independent third party. All ventilators must meet all applicable codes.





MODEL:

SHBCU-C-I-PA---

ADD THE OVERALL LENGTH (IN INCHES) OF THE VENTILATOR AFTER MODEL DESIGNATION

DAMPER TYPE
ND - NO DAMPER
FL - FUSIBLE LINK
T - THERMOSTAT

ADD THE OVERALL WIDTH (IN INCHES) OF THE VENTILATOR AFTER MODEL DESIGNATION

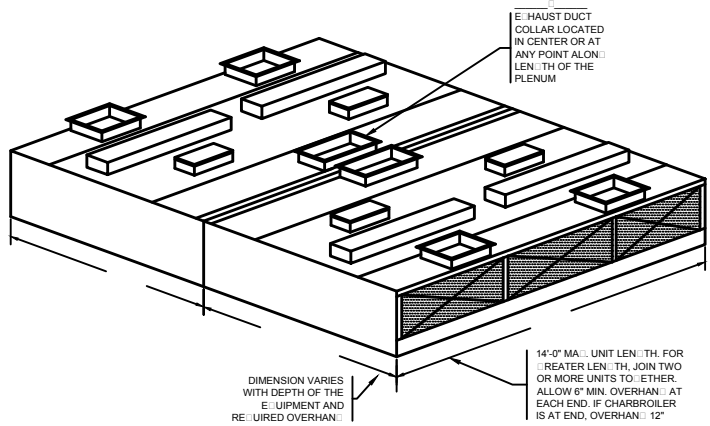

STANDARD LIGHT FIXTURES
() 100 WATT INCANDESCENT
() RECESSED INCANDESCENT
() RECESSED FLUORESCENT
(IF RECESSED FLUORESCENT SPECIFY SIZE)

CONSULT FACTORY FOR NON-STANDARD HEIGHTS

12" MIN. FRONT OVERHANG

6" MIN. SIDE OVERHANG
(12" MIN. SIDE OVERHANG FOR CHARBROILER)

ITEM # _____
EST. WEIGHT _____
LENGTH _____
WIDTH _____
HEIGHT _____
EXHAUST-CFM _____
DUCT SIZE _____
S.P. _____

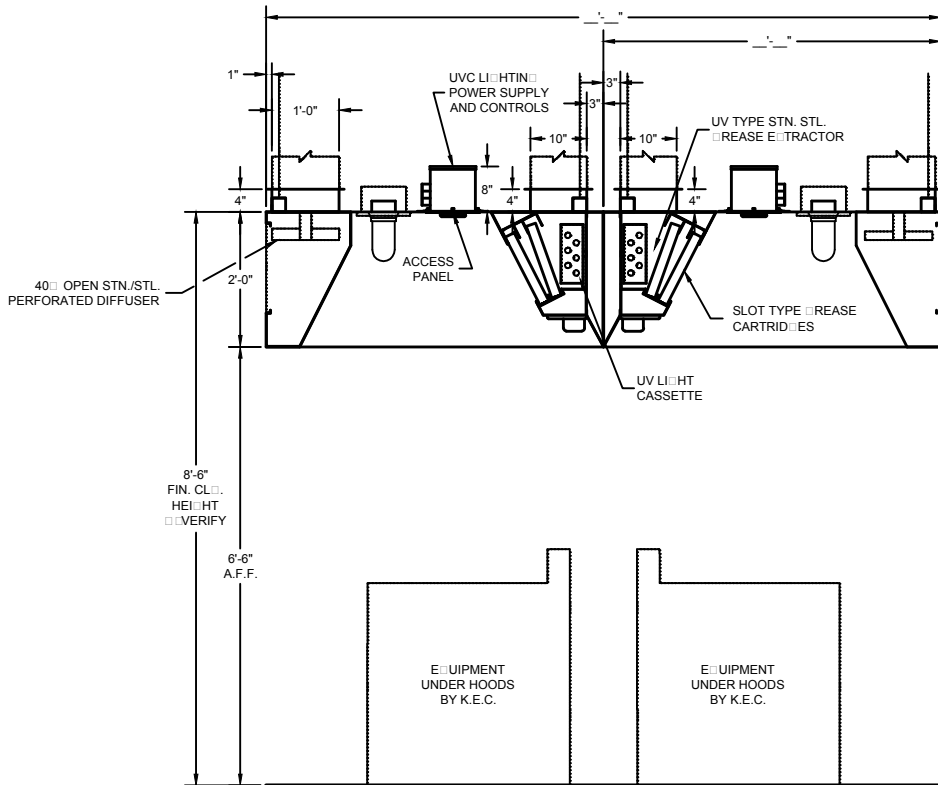

SECTION

DRAWINGS NOT TO SCALE

ENGINEERING DATA

Ventilator Length

Maximum ventilator length in a single section is 14'-0". For lengths greater than 14'-0", join two or more sections. Verify access conditions into building and kitchen space prior to length selection.

Ventilator Hanging Weight

Wt./lineal ft. Lbs. 105

NOTE: Refer to CADDY AirSystems

Master Engineering Data Sheet in engineering data section for determining light, medium, and heavy duty cooking equipment, C.F.M. requirements (exhaust and supply), duct collar sizes and static pressure requirements.

Electrical Requirements

Light fixtures to be powered by a 120/1/60 circuit. UV Ballast boxes require (1) 120/1/60 15 Amp circuit per ventilator. UV Control Panel requires a 120/1/60 15 Amp circuit.

Mechanical Requirements

The volume of exhaust required is a function of the type of cooking equipment served by the ventilator, and the type and volume of product cooked.



CADDY Air Systems

ITEM NO:

Model SHBCU-C-I

PROJECT:

Ultra-Violet Ventilator With Ceiling Supply Plenum

LOCATION:

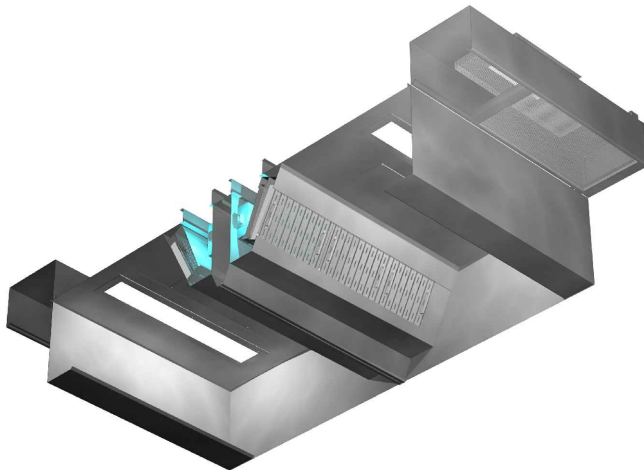
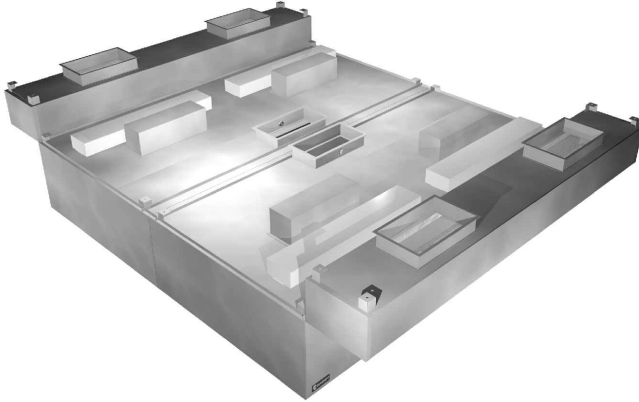

General Specifications

Furnish CADDY *AirSystems* Exhaust Hood Model SHBCU-C-I as shown on the plans and as described in the following specifications.

General

Exhaust ventilator shall be constructed of 18 gauge type 300 series stainless steel. All exposed surfaces to have a number 4 finish. Construction to meet all requirements of NFPA 96 and NSF Standard 2. To include necessary hanger brackets at front and rear for suspending from building overhead structure.

Description

The CADDY *AirSystems* Model "SHBCU" Series ventilator is an Ultra-Violet type and is ETL Listed under the standards as set forth in UL710 "Exhaust Hoods for Commercial Cooking Equipment". This ventilator uses Ultra-Violet light source technology for cleaning the inside of the hood. The ventilator shall be complete with a control panel with a ON/OFF switch, alarm reset button, alarm buzzer, and status lights to indicate power on, maintenance required, and light safety shut-down.

This ventilator is 95% grease extraction efficient when operated and maintained in accordance with design specifications. This high efficiency is accomplished by utilizing removable stainless steel baffle cartridges containing a series of horizontal, self-draining baffles. As the air is drawn around the baffles, the grease, dust and lint particles are slung from the airstream by centrifugal force. As the liquefied grease is extracted, it is drained off via a trough into grease collection containers at each end of the ventilator. At the end of the cooking day or at scheduled intervals, the baffle cartridges are removed for cleaning without having to climb up or onto the cooking equipment. Once removed, the baffle cartridges can be washed either in a dishwasher or soaked and rinsed off in a pot sink. Each baffle cartridge is a maximum of 19-1/2" long. The ventilator can be equipped with an optional fusible link type fire damper assembly.

Make-Up Air (Perimeter Down Discharge)

Ventilator shall have air registers along perimeter for down discharge of tempered make-up. Supply volume is 80% or designed to the desired air balance.

Application

Island style cooking applications for use over all types of cooking equipment where integral make-up air is required.

Light Fixtures

All light fixtures shall be pre-wired to a single connection point. Ventilators built in multiple sections to be furnished with junction boxes for ease of field connection by the Electrical Trades. Light bulbs furnished and installed by the Kitchen Equipment Contractor.

Exhaust Fans/Make-Up Air Units

Exhaust fans are to be provided and installed by others in compliance with local codes. Fans should be induced draft, squirrel cage design, equipped with backward inclined blades.

Fire Protection

NFPA Standard 96 and local codes require a fire extinguishing system for protection of the duct collar and plenum of all ventilators, as well as for the protection of various cooking appliances such as deep fat fryers, griddles, ranges, and broilers, which may be a source of ignition of grease. Consult factory and local fire officials for exact requirements. UL Listed fire protection systems may be pre-piped by Caddy at the time of manufacture, assuring concealment of piping and detectors.

Approvals

Ventilator shall be ETL listed, listed by NSF, and be in accordance with all of the recommendations set forth by NFPA's Standard 96. Filters tested to ASTM Standard F2519-05 by independent third party. All ventilators must meet all applicable codes.





MODEL:

SHBCU-C-I- [] - [] - []

ADD THE OVERALL LENGTH (IN INCHES) OF THE VENTILATOR AFTER MODEL DESIGNATION

DAMPER TYPE
ND - NO DAMPER
FL - FUSIBLE LINK
T - THERMOSTAT

ADD THE OVERALL WIDTH (IN INCHES) OF THE VENTILATOR AFTER MODEL DESIGNATION

EXHAUST DUCT COLLAR LOCATED IN CENTER OR AT ANY POINT ALONG LENGTH OF THE PLENUM

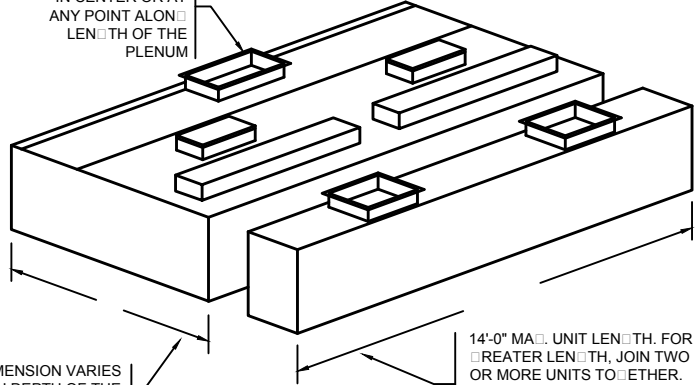

14'-0" MAX. UNIT LENGTH. FOR GREATER LENGTH, JOIN TWO OR MORE UNITS TOGETHER. ALLOW 6" MIN. OVERHANG AT EACH END. IF CHARBROILER IS AT END, OVERHANG 12"

DIMENSION VARIES WITH DEPTH OF THE EQUIPMENT AND REQUIRED OVERHANG

STANDARD LIGHT FIXTURES
() 100 WATT INCANDESCENT
() RECESSED INCANDESCENT
() RECESSED FLUORESCENT (IF RECESSED FLUORESCENT SPECIFY SIZE)

CONSULT FACTORY FOR NON-STANDARD HEIGHTS

22" MIN. FRONT OVERHANG

6" MIN. SIDE OVERHANG (12" MIN. SIDE OVERHANG FOR CHARBROILER)

ITEM # _____
EST. WEIGHT _____
LENGTH _____
WIDTH _____
HEIGHT _____
EXHAUST-CFM _____
DUCT SIZE _____
S.P. _____

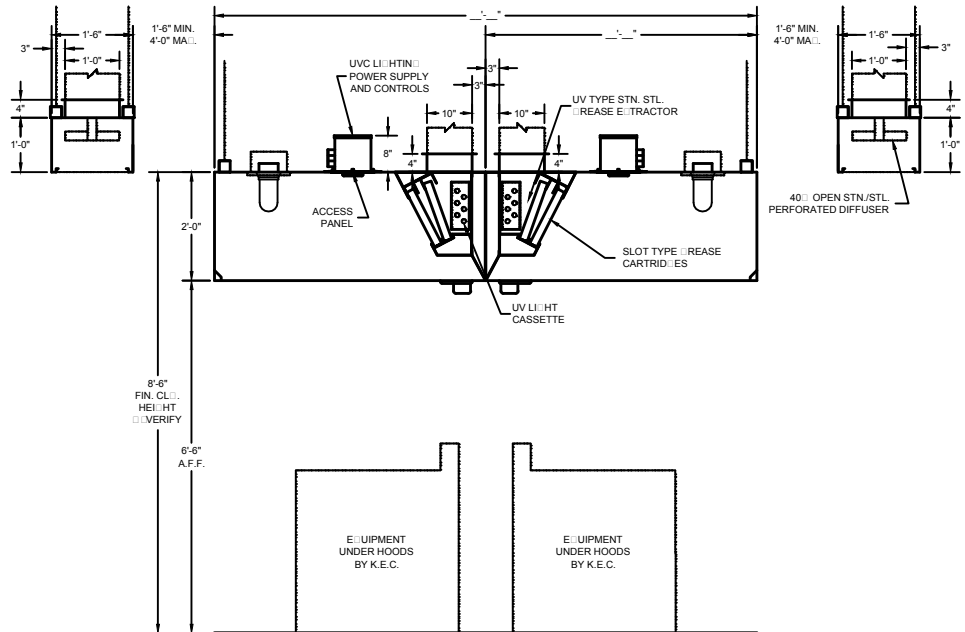

SECTION

DRAWINGS NOT TO SCALE

ENGINEERING DATA

Ventilator Length

Maximum ventilator length in a single section is 14'-0". For lengths greater than 14'-0", join two or more sections. Verify access conditions into building and kitchen space prior to length selection.

Ventilator Hanging Weight

Wt./lineal ft.	Lbs.	105
----------------	------	-----

Electrical Requirements

Light fixtures to be powered by a 120/1/60 circuit. UV Ballast boxes require (1) 120/1/60 15 Amp circuit per ventilator. UV Control Panel requires a 120/1/60 15 Amp circuit.

Mechanical Requirements

The volume of exhaust required is a function of the type of cooking equipment served by the ventilator, and the type and volume of product cooked.

NOTE: Refer to **CADDY AirSystems**

Master Engineering Data Sheet in engineering data section for determining light, medium, and heavy duty cooking equipment, C.F.M. requirements (exhaust and supply), duct collar sizes and static pressure requirements.



CADDY Air Systems

Model SHBCU-C-II Ultra-Violet Ventilator

ITEM NO:

PROJECT:

LOCATION:

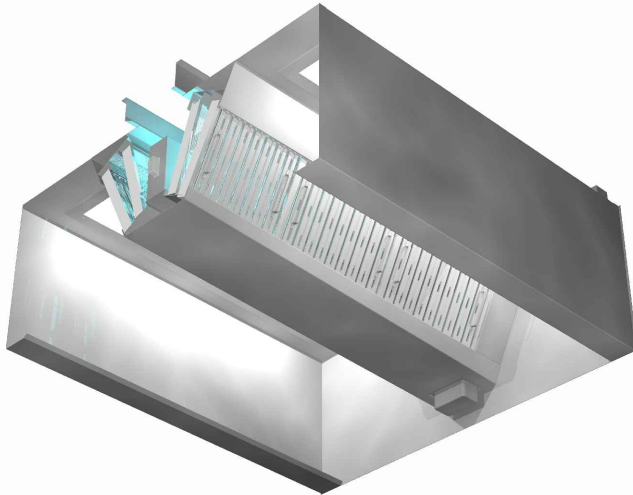
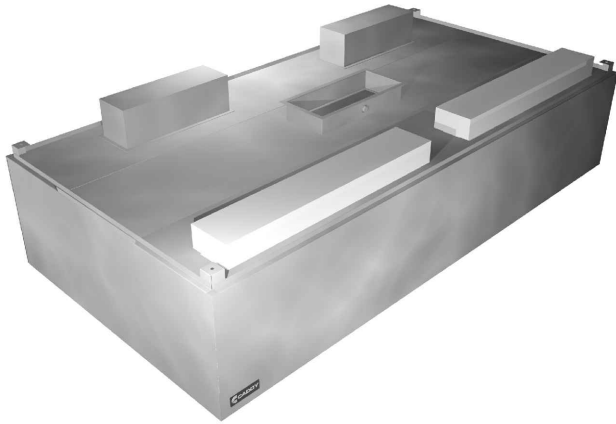

General Specifications

Furnish CADDY *AirSystems* Exhaust Hood Model **SHBCU-C-II** as shown on the plans and as described in the following specifications.

General

Exhaust ventilator shall be constructed of 18 gauge type 300 series stainless steel. All exposed surfaces to have a number 4 finish. Construction to meet all requirements of NFPA 96 and NSF Standard 2. To include necessary hanger brackets at front and rear for suspending from building overhead structure.

Description

The CADDY *AirSystems* Model "SHBCU" Series ventilator is an Ultra-Violet type and is ETL Listed under the standards as set forth in UL710 "Exhaust Hoods for Commercial Cooking Equipment". This ventilator uses Ultra-Violet light source technology for cleaning the inside of the hood. The ventilator shall be complete with a control panel with a ON/OFF switch, alarm reset button, alarm buzzer, and status lights to indicate power on, maintenance required, and light safety shut-down.

This ventilator is 95% grease extraction efficient when operated and maintained in accordance with design specifications. This high efficiency is accomplished by utilizing removable stainless steel baffle cartridges containing a series of horizontal, self-draining baffles. As the air is drawn around the baffles, the grease, dust and lint particles are slung from the airstream by centrifugal force. As the liquefied grease is extracted, it is drained off via a trough into grease collection containers at each end of the ventilator. At the end of the cooking day or at scheduled intervals, the baffle cartridges are removed for cleaning without having to climb up or onto the cooking equipment. Once removed, the baffle cartridges can be washed either in a dishwasher or soaked and rinsed off in a pot sink. Each baffle cartridge is a maximum of 19-1/2" long. The ventilator can be equipped with an optional fusible link type fire damper assembly.

Application

Island mounted exhaust-only canopy style for use over all types of cooking equipment.

Light Fixtures

All light fixtures shall be pre-wired to a single connection point. Ventilators built in multiple sections to be furnished with junction boxes for ease of field connection by the Electrical Trades. Light bulbs furnished and installed by the Kitchen Equipment Contractor.

Exhaust Fans/Make-Up Air Units

Exhaust fans are to be provided and installed by others in compliance with local codes. Fans should be induced draft, squirrel cage design, equipped with backward inclined blades.

Fire Protection

NFPA Standard 96 and local codes require a fire extinguishing system for protection of the duct collar and plenum of all ventilators, as well as for the protection of various cooking appliances such as deep fat fryers, griddles, ranges, and broilers, which may be a source of ignition of grease. Consult factory and local fire officials for exact requirements. UL Listed fire protection systems may be pre-piped by Caddy at the time of manufacture, assuring concealment of piping and detectors.

Approvals

Ventilator shall be ETL listed, listed by NSF, and be in accordance with all of the recommendations set forth by NFPA's Standard 96. Filters tested to ASTM Standard F2519-05 by independent third party. All ventilators must meet all applicable codes.





MODEL:

SHBCU-C-II---

ADD THE OVERALL LENGTH (IN INCHES) OF THE VENTILATOR AFTER MODEL DESIGNATION

DAMPER TYPE
ND - NO DAMPER
FL - FUSIBLE LINK
T - THERMOSTAT

ADD THE OVERALL WIDTH (IN INCHES) OF THE VENTILATOR AFTER MODEL DESIGNATION

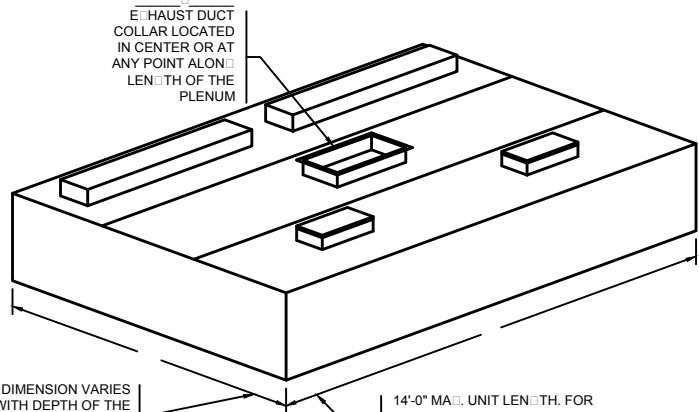

EXHAUST DUCT COLLAR LOCATED IN CENTER OR AT ANY POINT ALONG LENGTH OF THE PLENUM

DIMENSION VARIES WITH DEPTH OF THE EQUIPMENT AND REQUIRED OVERHANG

14'-0" MAX. UNIT LENGTH. FOR GREATER LENGTH, JOIN TWO OR MORE UNITS TOGETHER. ALLOW 6" MIN. OVERHANG AT EACH END. IF CHARBROILER IS AT END, OVERHANG 12"

STANDARD LIGHT FIXTURES
() 100 WATT INCANDESCENT
() RECESSED INCANDESCENT
() RECESSED FLUORESCENT
(IF RECESSED FLUORESCENT SPECIFY SIZE)

CONSULT FACTORY FOR NON-STANDARD HEIGHTS

12" MIN. FRONT OVERHANG

6" MIN. SIDE OVERHANG
(12" MIN. SIDE OVERHANG FOR CHARBROILER)

ITEM # _____
EST. WEIGHT _____
LENGTH _____
WIDTH _____
HEIGHT _____
EXHAUST-CFM _____
DUCT SIZE _____
S.P. _____

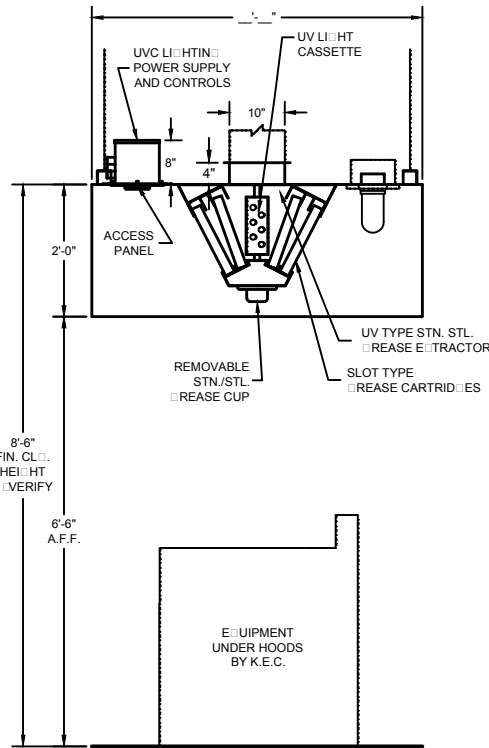

SECTION

DRAWINGS NOT TO SCALE

ENGINEERING DATA

Ventilator Length

Maximum ventilator length in a single section is 14'-0". For lengths greater than 14'-0", join two or more sections. Verify access conditions into building and kitchen space prior to length selection.

Ventilator Hanging Weight

Wt./lineal ft. Lbs. 90

NOTE: Refer to CADDY AirSystems

Master Engineering Data Sheet in engineering data section for determining light, medium, and heavy duty cooking equipment, C.F.M. requirements (exhaust and supply), duct collar sizes and static pressure requirements.

Electrical Requirements

Light fixtures to be powered by a 120/1/60 circuit. UV Ballast boxes require (1) 120/1/60 15 Amp circuit per ventilator. UV Control Panel requires a 120/1/60 15 Amp circuit.

Mechanical Requirements

The volume of exhaust required is a function of the type of cooking equipment served by the ventilator, and the type and volume of product cooked.



CADDY Air Systems

Model SHBCU-C-II-PA Ultra-Violet Ventilator

ITEM NO:

PROJECT:

LOCATION:

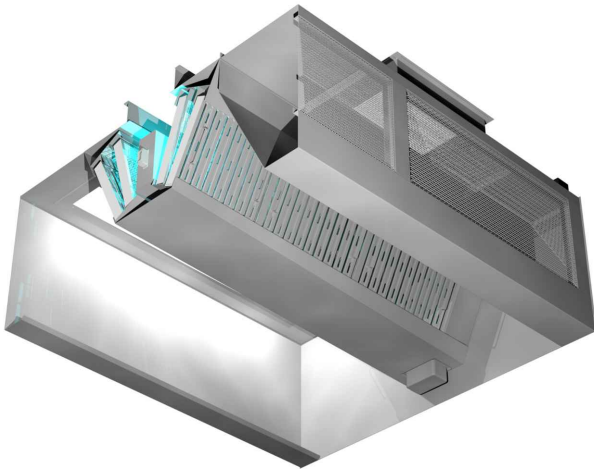
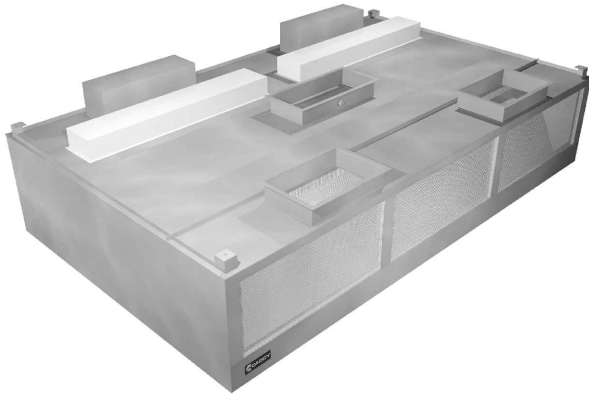

General Specifications

Furnish CADDY *AirSystems* Exhaust Hood Model **SHBCU-C-II-PA** as shown on the plans and as described in the following specifications.

General

Exhaust ventilator shall be constructed of 18 gauge type 300 series stainless steel. All exposed surfaces to have a number 4 finish. Construction to meet all requirements of NFPA 96 and NSF Standard 2. To include necessary hanger brackets at front and rear for suspending from building overhead structure.

Description

The CADDY *AirSystems* Model "SHBCU" Series ventilator is an Ultra-Violet type and is ETL Listed under the standards as set forth in UL710 "Exhaust Hoods for Commercial Cooking Equipment". This ventilator uses Ultra-Violet light source technology for cleaning the inside of the hood. The ventilator shall be complete with a control panel with a ON/OFF switch, alarm reset button, alarm buzzer, and status lights to indicate power on, maintenance required, and light safety shut-down. This ventilator is 95% grease extraction efficient when operated and maintained in accordance with design specifications.

This high efficiency is accomplished by utilizing removable stainless steel baffle cartridges containing a series of horizontal, self-draining baffles. As the air is drawn around the baffles, the grease, dust and lint particles are slung from the airstream by centrifugal force. As the liquefied grease is extracted, it is drained off via a trough into grease collection containers at each end of the ventilator. At the end of the cooking day or at scheduled intervals, the baffle cartridges are removed for cleaning without having to climb up or onto the cooking equipment. Once removed, the baffle cartridges can be washed either in a dishwasher or soaked and rinsed off in a pot sink. Each baffle cartridge is a maximum of 19-1/2" long. The ventilator can be equipped with an optional fusible link type fire damper assembly.

Make-Up Air (Front Face Discharge)

Ventilator shall have 40% open stainless steel perforated screens along front face for discharge of tempered make-up air. Supply volume is 80% or designed to the desired air balance.

Application

Island style cooking applications for use over all types of cooking equipment where integral make-up air is required.

Light Fixtures

All light fixtures shall be pre-wired to a single connection point. Ventilators built in multiple sections to be furnished with junction boxes for ease of field connection by the Electrical Trades. Light bulbs furnished and installed by the Kitchen Equipment Contractor.

Exhaust Fans/Make-Up Air Units

Exhaust fans are to be provided and installed by others in compliance with local codes. Fans should be induced draft, squirrel cage design, equipped with backward inclined blades.

Fire Protection

NFPA Standard 96 and local codes require a fire extinguishing system for protection of the duct collar and plenum of all ventilators, as well as for the protection of various cooking appliances such as deep fat fryers, griddles, ranges, and broilers, which may be a source of ignition of grease. Consult factory and local fire officials for exact requirements. UL Listed fire protection systems may be pre-piped by Caddy at the time of manufacture, assuring concealment of piping and detectors.

Approvals

Ventilator shall be ETL listed, listed by NSF, and be in accordance with all of the recommendations set forth by NFPA's Standard 96. Filters tested to ASTM Standard F2519-05 by independent third party. All ventilators must meet all applicable codes.





MODEL:

SHBCU-C-II-PA---

ADD THE OVERALL LENGTH (IN INCHES) OF THE VENTILATOR AFTER MODEL DESIGNATION

DAMPER TYPE
ND - NO DAMPER
FL - FUSIBLE LINK
T - THERMOSTAT

ADD THE OVERALL WIDTH (IN INCHES) OF THE VENTILATOR AFTER MODEL DESIGNATION

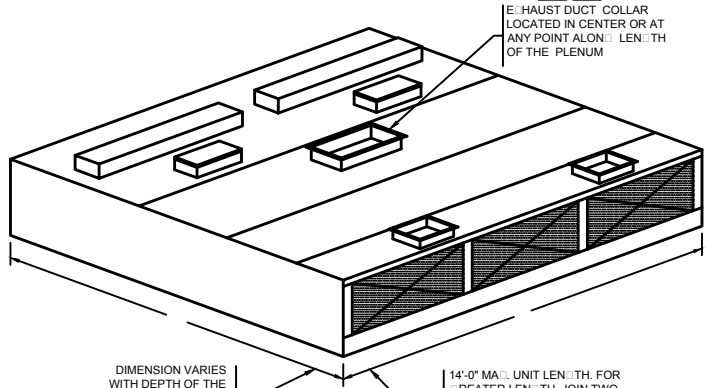

EXHAUST DUCT COLLAR LOCATED IN CENTER OR AT ANY POINT ALONG LENGTH OF THE PLENUM

DIMENSION VARIES WITH DEPTH OF THE EQUIPMENT AND REQUIRED OVERHANG

14'-0" MAX. UNIT LENGTH. FOR GREATER LENGTH, JOIN TWO OR MORE UNITS TOGETHER. ALLOW 6" MIN. OVERHANG AT EACH END. IF CHARBROILER IS AT END, OVERHANG 12"

STANDARD LIGHT FIXTURES
() 100 WATT INCANDESCENT
() RECESSED INCANDESCENT
() RECESSED FLUORESCENT (IF RECESSED FLUORESCENT SPECIFY SIZE)

CONSULT FACTORY FOR NON-STANDARD HEIGHTS

12" MIN. FRONT OVERHANG

6" MIN. SIDE OVERHANG (12" MIN. SIDE OVERHANG FOR CHARBROILER)

ITEM # _____
EST. WEIGHT _____
LENGTH _____
WIDTH _____
HEIGHT _____
EXHAUST-CFM _____
DUCT SIZE _____
S.P. _____

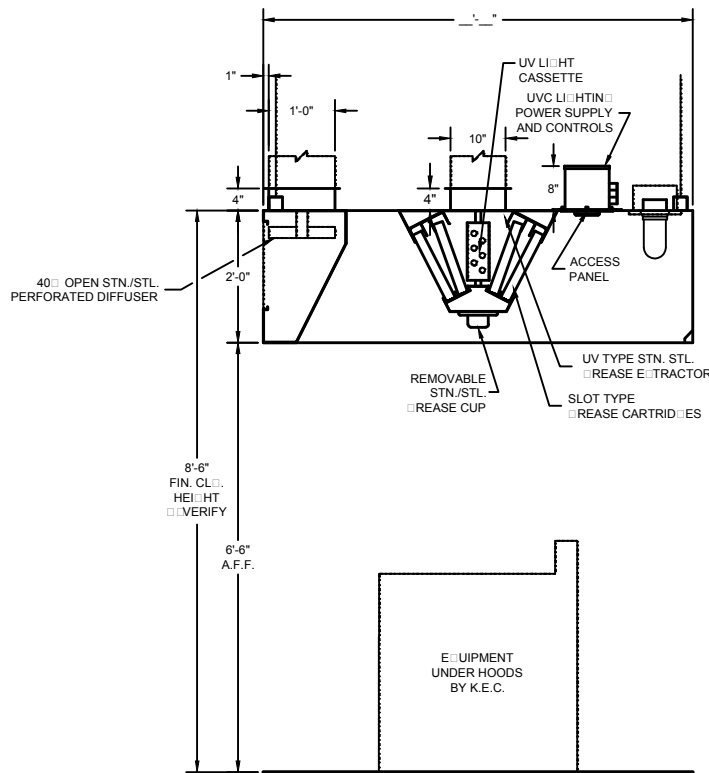

SECTION

DRAWINGS NOT TO SCALE

ENGINEERING DATA

Ventilator Length

Maximum ventilator length in a single section is 14'-0". For lengths greater than 14'-0", join two or more sections. Verify access conditions into building and kitchen space prior to length selection.

Ventilator Hanging Weight

Wt./lineal ft.	Lbs.	105
----------------	------	-----

Electrical Requirements

Light fixtures to be powered by a 120/1/60 circuit. UV Ballast boxes require (1) 120/1/60 15 Amp circuit per ventilator. UV Control Panel requires a 120/1/60 15 Amp circuit.

Mechanical Requirements

The volume of exhaust required is a function of the type of cooking equipment served by the ventilator, and the type and volume of product cooked.

NOTE: Refer to **CADDY AirSystems**

Master Engineering Data Sheet in engineering data section for determining light, medium, and heavy duty cooking equipment, C.F.M. requirements (exhaust and supply), duct collar sizes and static pressure requirements.



CADDY Air Systems

ITEM NO:

Model SHBCU-C-II Ultra-Violet Ventilator With Ceiling Supply Plenum

PROJECT:

LOCATION:

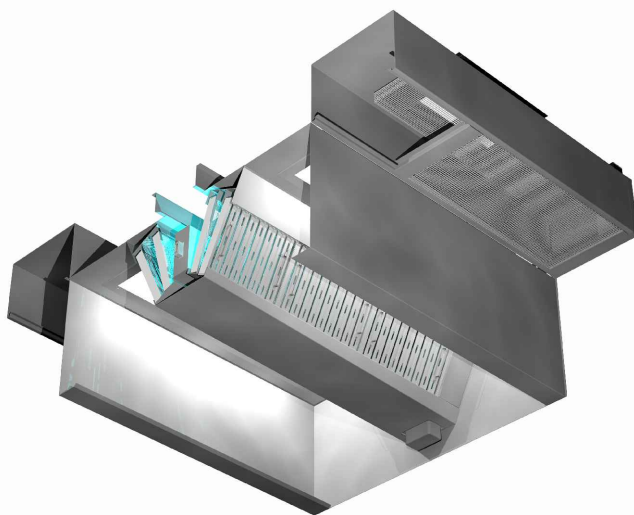

General Specifications

Furnish CADDY *AirSystems* Exhaust Hood Model **SHBCU-C-II** as shown on the plans and as described in the following specifications.

General

Exhaust ventilator shall be constructed of 18 gauge type 300 series stainless steel. All exposed surfaces to have a number 4 finish. Construction to meet all requirements of NFPA 96 and NSF Standard 2. To include necessary hanger brackets at front and rear for suspending from building overhead structure.

Description

The CADDY *AirSystems* Model "SHBCU" Series ventilator is an Ultra-Violet type and is ETL Listed under the standards as set forth in UL710 "Exhaust Hoods for Commercial Cooking Equipment". This ventilator uses Ultra-Violet light source technology for cleaning the inside of the hood. The ventilator shall be complete with a control panel with a ON/OFF switch, alarm reset button, alarm buzzer, and status lights to indicate power on, maintenance required, and light safety shut-down.

This ventilator is 95% grease extraction efficient when operated and maintained in accordance with design specifications. This high efficiency is accomplished by utilizing removable stainless steel baffle cartridges containing a series of horizontal, self-draining baffles. As the air is drawn around the baffles, the grease, dust and lint particles are slung from the airstream by centrifugal force. As the liquefied grease is extracted, it is drained off via a trough into grease collection containers at each end of the ventilator. At the end of the cooking day or at scheduled intervals, the baffle cartridges are removed for cleaning without having to climb up or onto the cooking equipment. Once removed, the baffle cartridges can be washed either in a dishwasher or soaked and rinsed off in a pot sink. Each baffle cartridge is a maximum of 19-1/2" long. The ventilator can be equipped with an optional fusible link type fire damper assembly.

Make-Up Air (Perimeter Down Discharge)

Ventilator shall have air registers along perimeter for down discharge of tempered make-up. Supply volume is 80% or designed to the desired air balance.

Application

Island style cooking applications for use over all types of cooking equipment where integral make-up air is required.

Light Fixtures

All light fixtures shall be pre-wired to a single connection point. Ventilators built in multiple sections to be furnished with junction boxes for ease of field connection by the Electrical Trades. Light bulbs furnished and installed by the Kitchen Equipment Contractor.

Exhaust Fans/Make-Up Air Units

Exhaust fans are to be provided and installed by others in compliance with local codes. Fans should be induced draft, squirrel cage design, equipped with backward inclined blades.

Fire Protection

NFPA Standard 96 and local codes require a fire extinguishing system for protection of the duct collar and plenum of all ventilators, as well as for the protection of various cooking appliances such as deep fat fryers, griddles, ranges, and broilers, which may be a source of ignition of grease. Consult factory and local fire officials for exact requirements. UL Listed fire protection systems may be pre-piped by Caddy at the time of manufacture, assuring concealment of piping and detectors.

Approvals

Ventilator shall be ETL listed, listed by NSF, and be in accordance with all of the recommendations set forth by NFPA's Standard 96. Filters tested to ASTM Standard F2519-05 by independent third party. All ventilators must meet all applicable codes.





MODEL:

SHBCU-C-II- - -

ADD THE OVERALL LENGTH (IN INCHES) OF THE VENTILATOR AFTER MODEL DESIGNATION

DAMPER TYPE
ND - NO DAMPER
FL - FUSIBLE LINK
T - THERMOSTAT

ADD THE OVERALL WIDTH (IN INCHES) OF THE VENTILATOR AFTER MODEL DESIGNATION

EXHAUST DUCT COLLAR LOCATED IN CENTER OR AT ANY POINT ALONG LENGTH OF THE PLENUM

DIMENSION VARIES WITH DEPTH OF THE EQUIPMENT AND REQUIRED OVERHANG

14'-0" MAX. UNIT LENGTH. FOR GREATER LENGTH, JOIN TWO OR MORE UNITS TOGETHER. ALLOW 6" MIN. OVERHANG AT EACH END. IF CHARBROILER IS AT END, OVERHANG 12"

STANDARD LIGHT FIXTURES
() 100 WATT INCANDESCENT
() RECESSED INCANDESCENT
() RECESSED FLUORESCENT
(IF RECESSED FLUORESCENT SPECIFY SIZE)

CONSULT FACTORY FOR NON-STANDARD HEIGHTS

22" MIN. FRONT OVERHANG

6" MIN. SIDE OVERHANG (12" MIN. SIDE OVERHANG FOR CHARBROILER)

ITEM	_____
EST. WEIGHT	_____
LENGTH	_____
WIDTH	_____
HEIGHT	_____
EXHAUST-CFM	_____
DUCT SIZE	_____
S.P.	_____

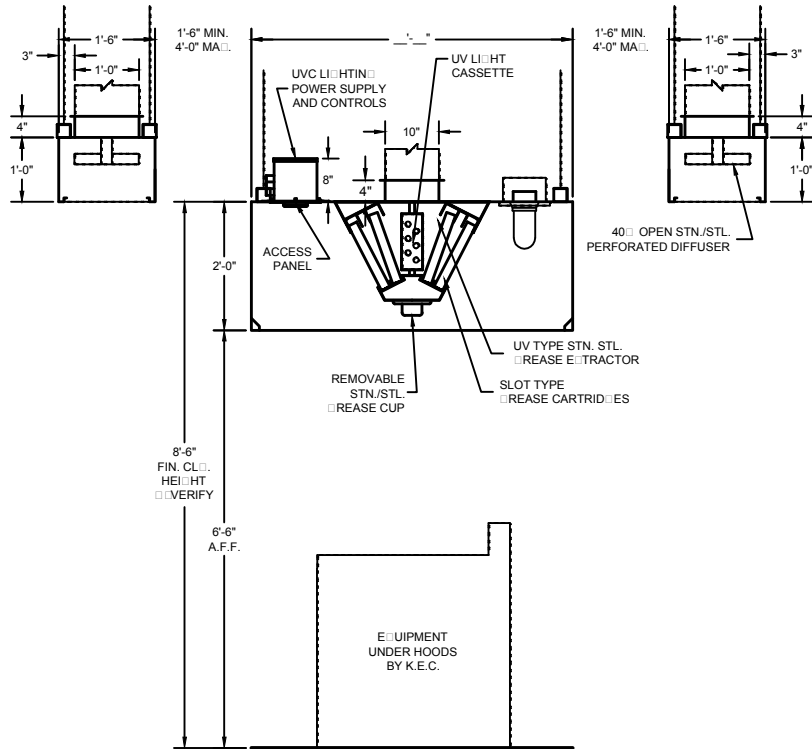

SECTION

DRAWINGS NOT TO SCALE

ENGINEERING DATA

Ventilator Length

Maximum ventilator length in a single section is 14'-0". For lengths greater than 14'-0", join two or more sections. Verify access conditions into building and kitchen space prior to length selection.

Ventilator Hanging Weight

Wt./lineal ft.	Lbs.	105
----------------	------	-----

NOTE: Refer to **CADDY AirSystems**

Master Engineering Data Sheet in engineering data section for determining light, medium, and heavy duty cooking equipment, C.F.M. requirements (exhaust and supply), duct collar sizes and static pressure requirements.

Electrical Requirements

Light fixtures to be powered by a 120/1/60 circuit. UV Ballast boxes require (1) 120/1/60 15 Amp circuit per ventilator. UV Control Panel requires a 120/1/60 15 Amp circuit.

Mechanical Requirements

The volume of exhaust required is a function of the type of cooking equipment served by the ventilator, and the type and volume of product cooked.



CADDY Air Systems

Options & Accessories

Lighting Options:

Multiple lighting options are available:

Dome Lights:
Incandescent
or LED



Recessed
12" x 12"
Incandescent

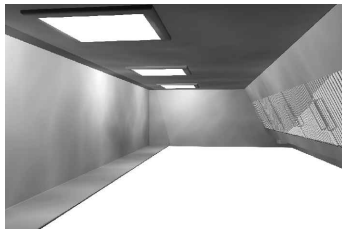

Recessed
24", 36" or 48"
Fluorescent
or LED

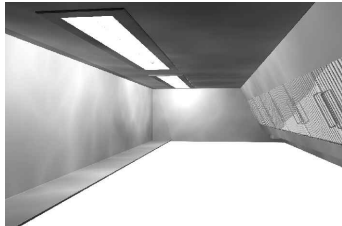

Recessed
10" x 10" LED
Fixtures

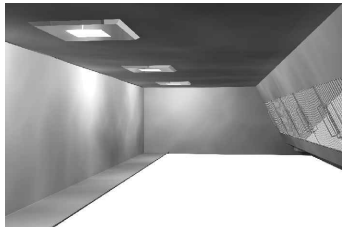

All fixtures are vapor proof and UL Approved.

Exhaust Collars:

- Factory Mounted: Collars are fully welded to the exhaust plenum and include a 1 inch flange.
- Shipped Loose: exhausts openings can be cut on site when exact locations are not known.
- Shape: Rectangular or Round to accommodate ductwork.
- Location: Top, back, or side.

Supply Collars:

- Shipped Loose
- Shape: Rectangular or Round
- Number: Variable

Tapered Hood: Available to accommodate low ceiling applications.



Enclosure Panels:



Stainless Steel Wall Flashing:



 **CADDY CORPORATION**
509 Sharptown Road P.O. Box 345
Bridgeport, NJ 08014-0345
Tel: 856-467-4222 Fax: 856-467-5511
internet: www.caddycorp.com



CADDY CORPORATION

Food Service Equipment

Air Systems

Control Panel for
Ultra-Violet Ventilators

Model CPE-U

Model CPE-U

Control Cabinets for Ultra-Violet Ventilators

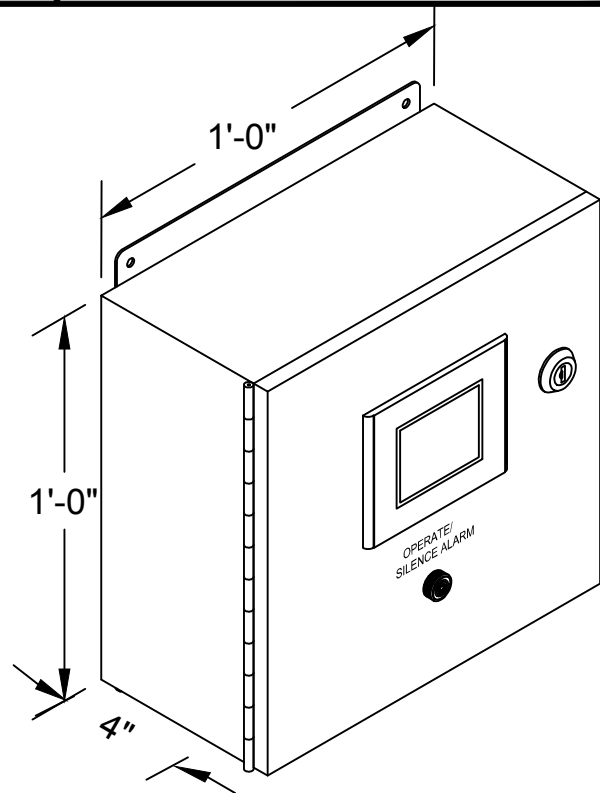
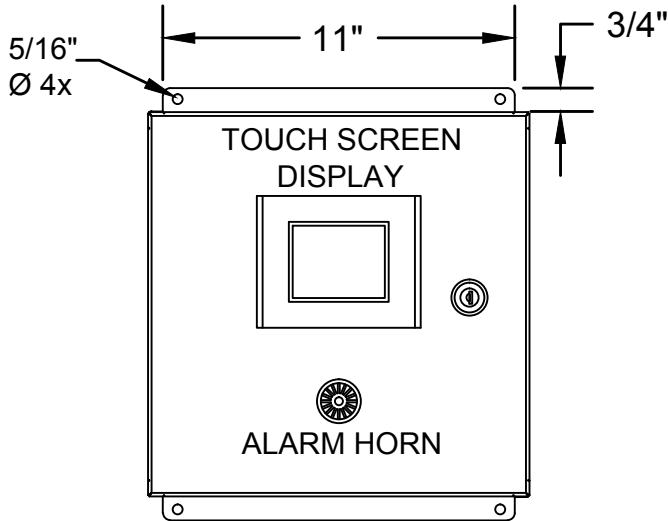

MODEL CPE-U

GENERAL DESCRIPTION

Control cabinet shall be furnished with ventilator. Control cabinet to house all electrical components and interlocks for the monitoring of the UVC light system, fire protection system and exhaust fan operation. The control cabinet to be constructed of 18 gauge stainless steel, $\square 4$ finish, with welded corners and hinged door electrical compartment. The electrical cabinet to be water tight to protect against direct hose spray. The control panel shall be equipped with a touch screen display indicating kitchen Exhaust Fan On / Off switch, Alarm Reset push-button, alarm buzzer and lamps to indicate Power On, Maintenance required, light safety shut down. Control cabinet to be U.L. Listed.

SEQUENCE OF OPERATIONS

- Main switch set to "Auto", "EMS" system will start system
- Main switch set to "Hand On" system will start
- In case of fire, Supply air and UV bulb power will be shut off, Alarm will sound
- If a filter is missing, alarm will sound, "UV" bulb power will be shut off.
- If "Sense" board in ballast box senses faulty light bulb, alarm will sound
- If timer reaches 7000 hours, alarm will sound
- * All alarm signals will be able to be shut off at touch screen

Model CPE-U Control Cabinets for Ultra-Violet Ventilators

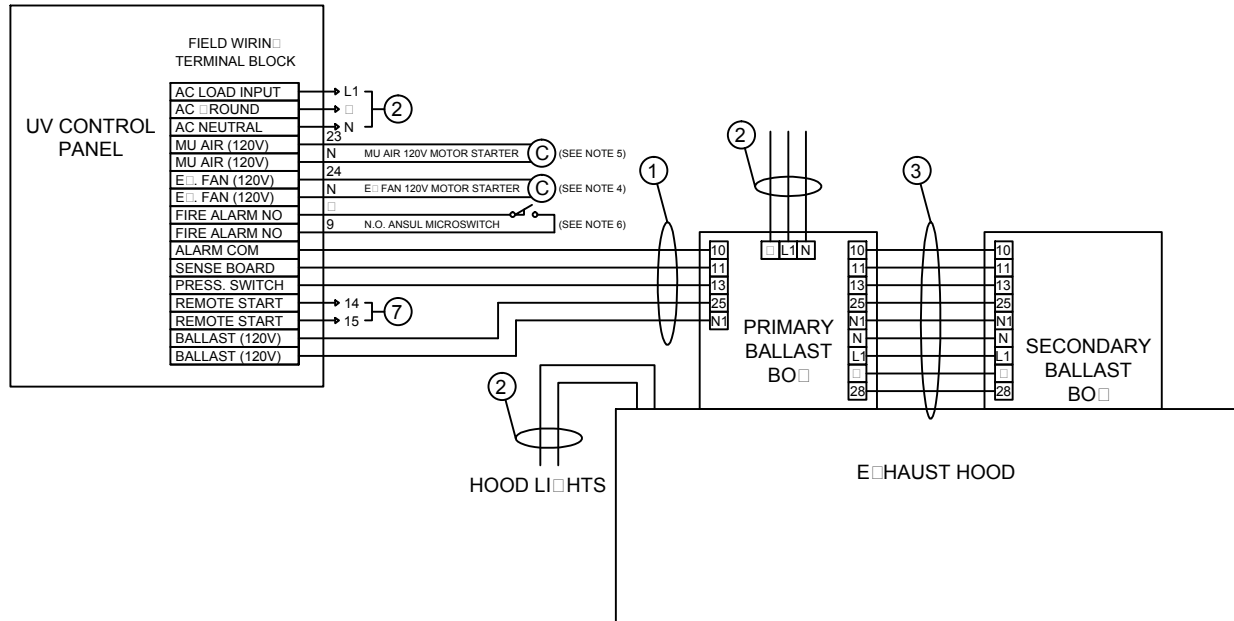

1. 5 WIRE INTERLOCK BY ELECTRICAL CONTRACTOR
2. 120/1 15 AMP POWER SUPPLY BY ELECTRICAL CONTRACTOR
3. 9 WIRE INTERLOCK BY CADDY
4. 2 WIRE 120V INTERLOCK BY ELECTRICAL CONTRACTOR TO ENERGIZE E EXHAUST FAN MOTOR COIL WHEN UV SYSTEM IS TURNED ON.
5. 2 WIRE 120V INTERLOCK BY ELECTRICAL CONTRACTOR TO ENERGIZE MAKE-UP AIR FAN MOTOR COIL WHEN UV SYSTEM IS TURNED ON.
6. 2 WIRE 24V LOW VOLTAGE INTERLOCK FROM ANSUL MICROSWITCH BY ELECTRICAL CONTRACTOR.
7. 2 WIRES TO BUILDING AUTOMATION SYSTEM, IF APPLICABLE



CADDY CORPORATION

Food Service Equipment

Air Systems

Commercial Kitchen Exhaust Systems

Model SHC

Dry Extractor Style



CADDY CORPORATION

Food Service Equipment

Air Systems

Commercial Kitchen Exhaust Systems

Model SHC
Wall Mount Style

Model SHC-C-W Dry Cartridge Ventilator

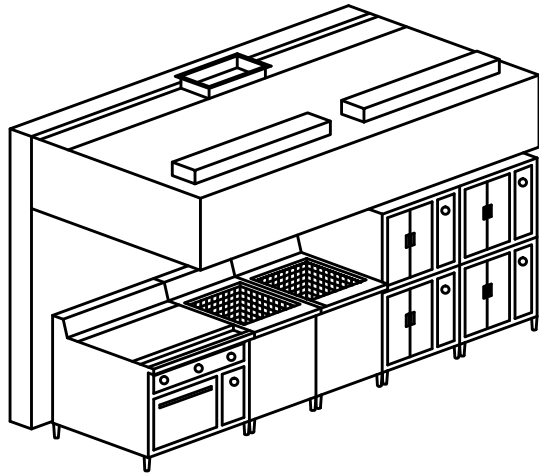

General Specifications

Furnish CADDY *AirSystems* Exhaust Hood Model **SHC-C-W** as shown on the plans and as described in the following specifications.

General

Exhaust Ventilator shall be constructed of 18 gauge type 300 series stainless steel. All exposed surfaces to have a #4 finish. Construction to meet all requirements of NFPA 96 and NSF Standard No. 2. To include necessary hanger brackets at front and rear suspending from building overhead structure.

Description

The CADDY *AirSystems* Model "SHC" Ventilator is a dry extractor cartridge type and is UL listed under the standards as set forth in UL710 "Exhaust Hoods for Commercial Cooking Equipment." This ventilator is 95% grease extraction efficient when operated and maintained in accordance with design specifications. This high efficiency is accomplished by utilizing removable stainless steel extractor cartridges containing a series of horizontal, self-draining baffles. As the air is drawn around the baffles, the grease, dust and lint particles are slung from the air stream by centrifugal force. As the liquefied grease is extracted, it is drawn off via a trough into grease collection containers at each end of the ventilator. At the end of the cooking day or at scheduled intervals, the cartridges are removed for cleaning without having to climb up or onto the cooking equipment with the use of an extractor removal pot sink. Each cartridge is a maximum of 19-1/2" long. Ventilator can also be quipped with an optional fusible link or thermostatically activated fire damper assembly.

Application

Wall mounted exhaust-only canopy style for use over all types of cooking equipment.

Light Fixtures

All light fixtures shall be pre-wired to a single connection point. Ventilators built in multiple sections to be furnished with junction boxes for ease of field connection by the electrical trades. Light bulbs furnished and installed by the Kitchen Equipment Contractor.

Exhaust Fans

Exhaust fans are to be provided and installed by others in compliance with local codes. **Fans should be induced draft, squirrel cage design, equipped with backward inclined blades.**

Fire Protection

NFPA 96 and local codes require a fire extinguishing system for protection of the duct collar and plenum of all ventilators, as well as for the protection of various cooking appliances such as deep fat fryers, griddles, ranges, and broilers, which may be a source of ignition of grease. Consult factory and local fire officials for exact requirements. UL Listed fire protection systems may be pre-piped by Caddy at the time of manufacture, assuring concealment of piping and detectors.

Approvals

Ventilator shall be UL Listed, listed by NSF and be in accordance with all of the recommendations set forth by NFPA 96. All ventilators must meet all applicable codes.



MODEL:

SHC-C-W - [] - [] - []

ADD THE OVERALL LENGTH (IN INCHES) OF THE VENTILATOR AFTER MODEL DESIGNATION

DAMPER TYPE
ND - NO DAMPER
FL - FUSIBLE LINK
T - THERMOSTAT

ADD THE OVERALL WIDTH (IN INCHES) OF THE VENTILATOR AFTER MODEL DESIGNATION

X
EXHAUST DUCT COLLAR LOCATED IN CENTER OR AT ANY POINT ALONG LENGTH OF THE PLENUM

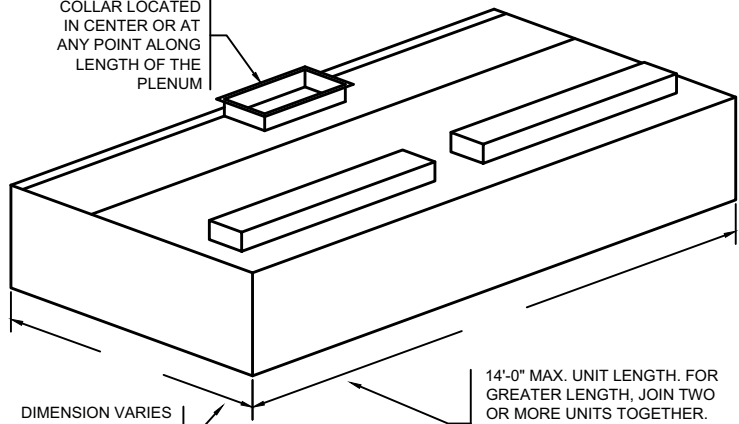

14'-0" MAX. UNIT LENGTH. FOR GREATER LENGTH, JOIN TWO OR MORE UNITS TOGETHER. ALLOW 6" MIN. OVERHANG AT EACH END. IF CHARBROILER IS AT END, OVERHANG 12"

DIMENSION VARIES WITH DEPTH OF THE EQUIPMENT AND REQUIRED OVERHANG

STANDARD LIGHT FIXTURES
 100 WATT INCANDESCENT
 RECESSED INCANDESCENT
 RECESSED FLUORESCENT
 (IF RECESSED FLUORESCENT SPECIFY SIZE)

CONSULT FACTORY FOR NON-STANDARD HEIGHTS
 12" MIN. FRONT OVERHANG
 6" MIN. SIDE OVERHANG
 (12" MIN. SIDE OVERHANG FOR CHARBROILER)

ITEM #	_____
EST. WEIGHT	_____
LENGTH	_____
WIDTH	_____
HEIGHT	_____
EXHAUST-CFM	_____
DUCT SIZE	_____
S.P.	_____

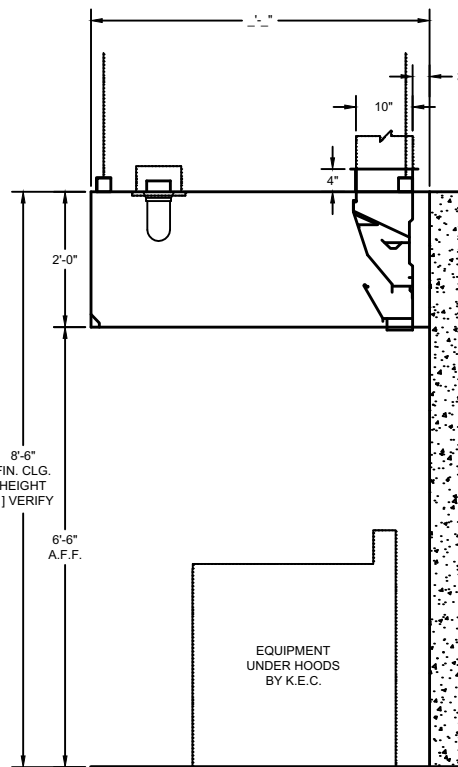

SECTION

DRAWINGS NOT TO SCALE

ENGINEERING DATA

Ventilator Length

Maximum ventilator length in a single section is 14'-0". For lengths greater than 14'-0", join two or more sections. Verify access conditions into building and kitchen space prior to length selection.

Ventilator Hanging Weight

Wt./ lineal ft.	Lbs.	75
-----------------	------	----

NOTE: Refer to CADDY AirSystems

Master Engineering Data Sheet in engineering data section for determining light, medium, and heavy duty cooking equipment, C.F.M. requirements (exhaust and supply), duct collar sizes and static pressure requirements.

Electrical Requirements

Light fixtures to be powered by a 120/1/60 circuit.

Mechanical Requirements

The volume of exhaust required is a function of the type of cooking equipment served by the ventilator, and the type and volume of product cooked. Refer to the CADDY AirSystems

Master Engineering Data Chart to determine exhaust volume, duct collar sizes, static pressure drop.



Model SHC-C-W-PA Dry Cartridge Ventilator

ITEM NO:

PROJECT:

LOCATION:

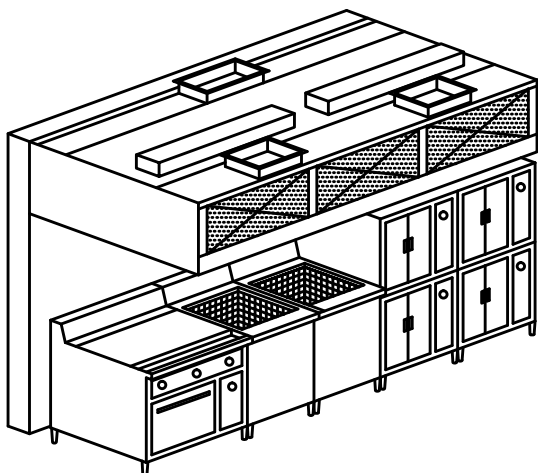

General Specifications

Furnish CADDY *AirSystems* Exhaust Hood Model **SHC-C-W-PA** as shown on the plans and as described in the following specifications.

General

Exhaust Ventilator shall be constructed of 18 gauge type 300 series stainless steel. All exposed surfaces to have a #4 finish. Construction to meet all requirements of NFPA 96 and NSF Standard No. 2. To include necessary hanger brackets at front and rear suspending from building overhead structure.

Description

The CADDY *AirSystems* Model "SHC" Ventilator is a dry extractor cartridge type and is UL listed under the standards as set forth in UL710 "Exhaust Hoods for Commercial Cooking Equipment." This ventilator is 95% grease extraction efficient when operated and maintained in accordance with design specifications. This high efficiency is accomplished by utilizing removable stainless steel extractor cartridges containing a series of horizontal, self-draining baffles. As the air is drawn around the baffles, the grease, dust and lint particles are slung from the air stream by centrifugal force. As the liquefied grease is extracted, it is drawined off via a trough into grease collection containers at each end of the ventilator. At the end of the cooking day or at scheduled intervals, the cartridges are removed for cleaning without having to climb up or onto the cooking equipment with the use of an extractor removal pot sink. Each cartridge is a maximum of 19-1/2" long. Ventilator can also be quipped with an optional fusible link or thermostatically activated fire damper assembly.

Make-Up Air (Front Face Discharge)

Ventilator shall have 40% open stainless steel perforated screens along front face for discharge of tempered make-up air. Supply volume is 80% or designed to the desired air balance.

Application

Wall mounted canopy style for use over all types of cooking equipment where integral make-up air is required.

Light Fixtures

All light fixtures shall be pre-wired to a single connection point. Ventilators built in multiple sections to be furnished with junction boxes for ease of field connection by the electrical trades. Light bulbs furnished and installed by the Kitchen Equipment Contractor.

Exhaust Fans

Exhaust fans are to be provided and installed by others in compliance with local codes. **Fans should be induced draft, squirrel cage design, equipped with backward inclined blades.**

Fire Protection

NFPA 96 and local codes require a fire extinguishing system for protection of the duct collar and plenum of all ventilators, as well as for the protection of various cooking appliances such as deep fat fryers, griddles, ranges, and broilers, which may be a source of ignition of grease. Consult factory and local fire officials for exact requirements. UL Listed fire protection systems may be pre-piped by Caddy at the time of manufacture, assuring concealment of piping and detectors.

Approvals

Ventilator shall be UL Listed, listed by NSF and be in accordance with all of the recommendations set forth by NFPA 96. All ventilators must meet all applicable codes.

 **CADDY CORPORATION**
509 Sharptown Road P.O. Box 345
Bridgeport, NJ 08014-0345
Tel: 856-467-4222 Fax: 856-467-5511
internet: www.caddycorp.com



MODEL:

SHC-C-W-PA---

ADD THE OVERALL LENGTH (IN INCHES) OF THE VENTILATOR AFTER MODEL DESIGNATION

DAMPER TYPE
ND - NO DAMPER
FL - FUSIBLE LINK
T - THERMOSTAT

ADD THE OVERALL WIDTH (IN INCHES) OF THE VENTILATOR AFTER MODEL DESIGNATION

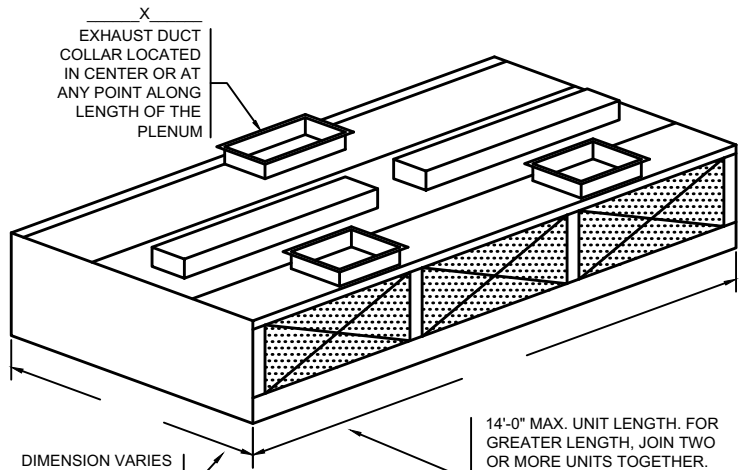

14'-0" MAX. UNIT LENGTH. FOR GREATER LENGTH, JOIN TWO OR MORE UNITS TOGETHER. ALLOW 6" MIN. OVERHANG AT EACH END. IF CHARBROILER IS AT END, OVERHANG 12"

DIMENSION VARIES WITH DEPTH OF THE EQUIPMENT AND REQUIRED OVERHANG

STANDARD LIGHT FIXTURES
 100 WATT INCANDESCENT
 RECESSED INCANDESCENT
 RECESSED FLUORESCENT
 (IF RECESSED FLUORESCENT SPECIFY SIZE)

CONSULT FACTORY FOR NON-STANDARD HEIGHTS
 12" MIN. FRONT OVERHANG
 6" MIN. SIDE OVERHANG
 (12" MIN. SIDE OVERHANG FOR CHARBROILER)

ITEM #	_____
EST. WEIGHT	_____
LENGTH	_____
WIDTH	_____
HEIGHT	_____
EXHAUST-CFM	_____
DUCT SIZE	_____
S.P.	_____

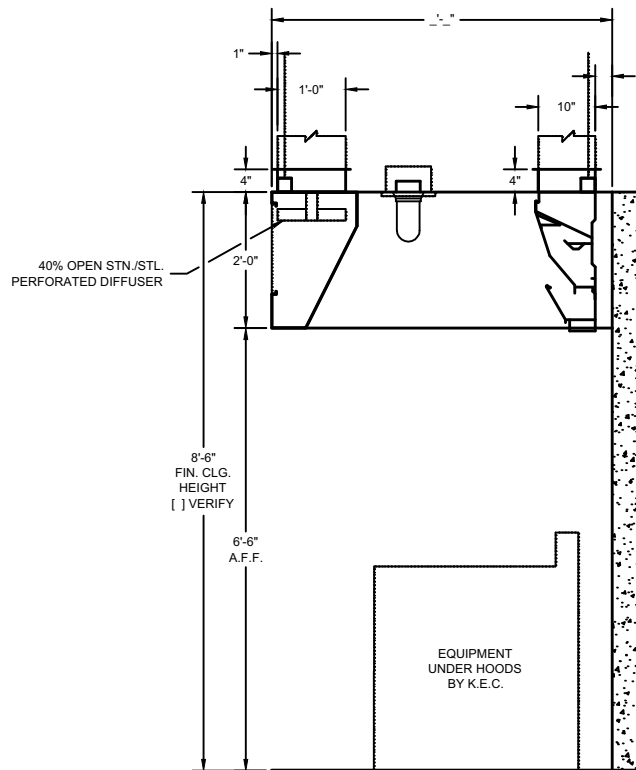

SECTION

DRAWINGS NOT TO SCALE

ENGINEERING DATA

Ventilator Length

Maximum ventilator length in a single section is 14'-0". For lengths greater than 14'-0", join two or more sections. Verify access conditions into building and kitchen space prior to length selection.

Ventilator Hanging Weight

Wt./ lineal ft.	Lbs.	90
-----------------	------	----

NOTE: Refer to CADDY AirSystems

Master Engineering Data Sheet in engineering data section for determining light, medium, and heavy duty cooking equipment, C.F.M. requirements (exhaust and supply), duct collar sizes and static pressure requirements.

Electrical Requirements

Light fixtures to be powered by a 120/1/60 circuit.

Mechanical Requirements

The volume of exhaust required is a function of the type of cooking equipment served by the ventilator, and the type and volume of product cooked. Refer to the **CADDY AirSystems**

Master Engineering Data Chart to determine exhaust volume, duct collar sizes, static pressure drop.



Model SHC-C-W-ASI Dry Cartridge Ventilator

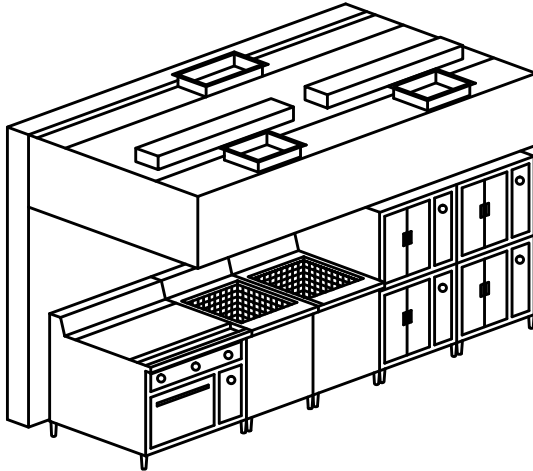

General Specifications

Furnish CADDY *AirSystems* Exhaust Hood Model **SHC-C-W-ASI** as shown on the plans and as described in the following specifications.

General

Exhaust Ventilator shall be constructed of 18 gauge type 300 series stainless steel. All exposed surfaces to have a #4 finish. Construction to meet all requirements of NFPA 96 and NSF Standard No. 2. To include necessary hanger brackets at front and rear suspending from building overhead structure.

Description

The CADDY *AirSystems* Model "SHC" Ventilator is a dry extractor cartridge type and is UL listed under the standards as set forth in UL710 "Exhaust Hoods for Commercial Cooking Equipment." This ventilator is 95% grease extraction efficient when operated and maintained in accordance with design specifications. This high efficiency is accomplished by utilizing removable stainless steel extractor cartridges containing a series of horizontal, self-draining baffles. As the air is drawn around the baffles, the grease, dust and lint particles are slung from the air stream by centrifugal force. As the liquefied grease is extracted, it is drawined off via a trough into grease collection containers at each end of the ventilator. At the end of the cooking day or at scheduled intervals, the cartridges are removed for cleaning without having to climb up or onto the cooking equipment with the use of an extractor removal pot sink. Each cartridge is a maximum of 19-1/2" long. Ventilator can also be quipped with an optional fusible link or thermostatically activated fire damper assembly.

Make-Up Air (Internal Discharge)

Ventilator shall have a fully insulated supply plenum with duct collar/fire damper assemblies and air registers internally mounted for discharging untempered make-up air directly into canopy of ventilator. The amount of make-up air supplied through this design is directly related to the type of cooking equipment located beneath the hood. The percentage of supply air distributed will vary as a function of the thermal currents generated by each individual appliance. When specifying this style, consult factory for specific supply volumes. This air may be untempered in most areas, depending upon climatic conditions and the type of cooking equipment.

Application

Wall mounted canopy style for use over all types of cooking equipment where integral make-up air is required.

Light Fixtures

All light fixtures shall be pre-wired to a single connection point. Ventilators built in multiple sections to be furnished with junction boxes for ease of field connection by the electrical trades. Light bulbs furnished and installed by the Kitchen Equipment Contractor.

Exhaust Fans

Exhaust fans are to be provided and installed by others in compliance with local codes. **Fans should be induced draft, squirrel cage design, equipped with backward inclined blades.**

Fire Protection

NFPA 96 and local codes require a fire extinguishing system for protection of the duct collar and plenum of all ventilators, as well as for the protection of various cooking appliances such as deep fat fryers, griddles, ranges, and broilers, which may be a source of ignition of grease. Consult factory and local fire officials for exact requirements. UL Listed fire protection systems may be pre-piped by Caddy at the time of manufacture, assuring concealment of piping and detectors.

Approvals

Ventilator shall be UL Listed, listed by NSF and be in accordance with all of the recommendations set forth by NFPA 96. All ventilators must meet all applicable codes.



MODEL:

SHC-C-W-ASI---

ADD THE OVERALL LENGTH (IN INCHES) OF THE VENTILATOR AFTER MODEL DESIGNATION

DAMPER TYPE
ND - NO DAMPER
FL - FUSIBLE LINK
T - THERMOSTAT

ADD THE OVERALL WIDTH (IN INCHES) OF THE VENTILATOR AFTER MODEL DESIGNATION

X
EXHAUST DUCT COLLAR LOCATED IN CENTER OR AT ANY POINT ALONG LENGTH OF THE PLENUM

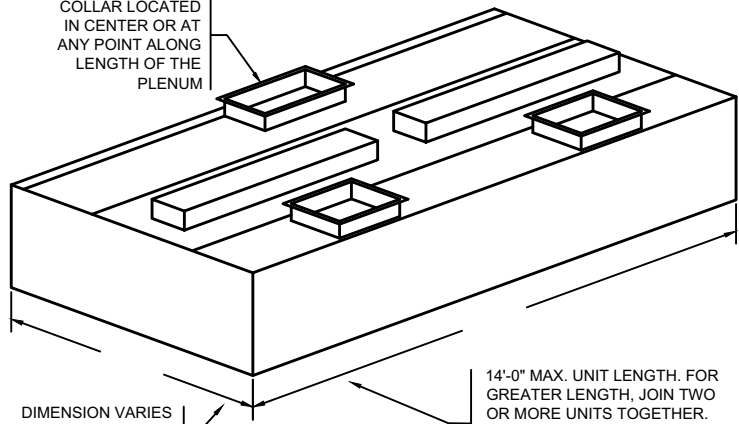

14'-0" MAX. UNIT LENGTH. FOR GREATER LENGTH, JOIN TWO OR MORE UNITS TOGETHER. ALLOW 6" MIN. OVERHANG AT EACH END. IF CHARBROILER IS AT END, OVERHANG 12"

DIMENSION VARIES WITH DEPTH OF THE EQUIPMENT AND REQUIRED OVERHANG

STANDARD LIGHT FIXTURES
 100 WATT INCANDESCENT
 RECESSED INCANDESCENT
 RECESSED FLUORESCENT
 (IF RECESSED FLUORESCENT SPECIFY SIZE)

CONSULT FACTORY FOR NON-STANDARD HEIGHTS
 22" MIN. FRONT OVERHANG
 6" MIN. SIDE OVERHANG (12" MIN. SIDE OVERHANG FOR CHARBROILER)

ITEM #	_____
EST. WEIGHT	_____
LENGTH	_____
WIDTH	_____
HEIGHT	_____
EXHAUST-CFM	_____
DUCT SIZE	_____
S.P.	_____

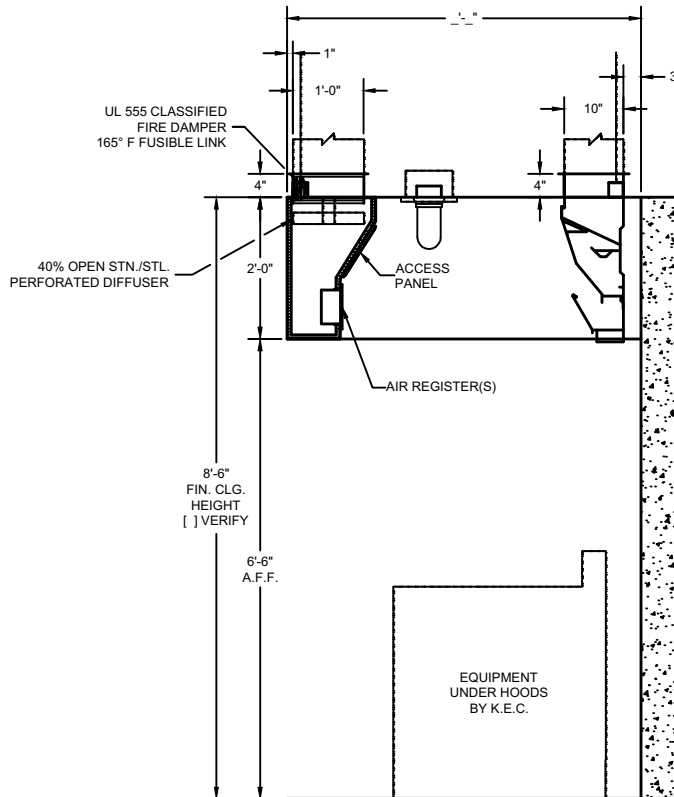

SECTION

DRAWINGS NOT TO SCALE

ENGINEERING DATA

Ventilator Length

Maximum ventilator length in a single section is 14'-0". For lengths greater than 14'-0", join two or more sections. Verify access conditions into building and kitchen space prior to length selection.

Ventilator Hanging Weight

Wt./ lineal ft.	Lbs.	90
-----------------	------	----

NOTE: Refer to CADDY AirSystems

Master Engineering Data Sheet in engineering data section for determining light, medium, and heavy duty cooking equipment, C.F.M. requirements (exhaust and supply), duct collar sizes and static pressure requirements.

Electrical Requirements

Light fixtures to be powered by a 120/1/60 circuit.

Mechanical Requirements

The volume of exhaust required is a function of the type of cooking equipment served by the ventilator, and the type and volume of product cooked. Refer to the **CADDY AirSystems**

Master Engineering Data Chart to determine exhaust volume, duct collar sizes, static pressure drop.



Model SHC-C-W-AA Dry Cartridge Ventilator

ITEM NO:

PROJECT:

LOCATION:

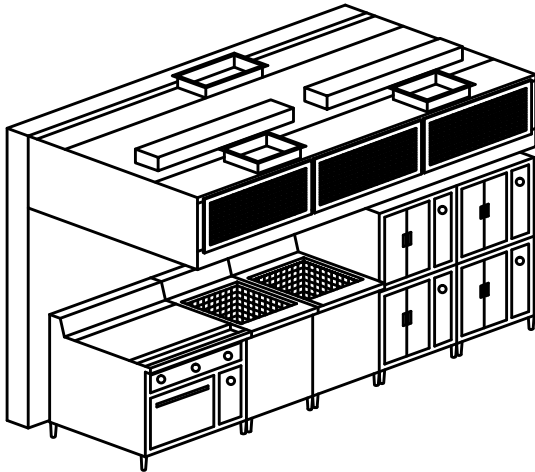

General Specifications

Furnish CADDY *AirSystems* Exhaust Hood Model **SHC-C-W-AA** as shown on the plans and as described in the following specifications.

General

Exhaust Ventilator shall be constructed of 18 gauge type 300 series stainless steel. All exposed surfaces to have a #4 finish. Construction to meet all requirements of NFPA 96 and NSF Standard No. 2. To include necessary hanger brackets at front and rear suspending from building overhead structure.

Description

The CADDY *AirSystems* Model "SHC" Ventilator is a dry extractor cartridge type and is UL listed under the standards as set forth in UL710 "Exhaust Hoods for Commercial Cooking Equipment." This ventilator is 95% grease extraction efficient when operated and maintained in accordance with design specifications. This high efficiency is accomplished by utilizing removable stainless steel extractor cartridges containing a series of horizontal, self-draining baffles. As the air is drawn around the baffles, the grease, dust and lint particles are slung from the air stream by centrifugal force. As the liquefied grease is extracted, it is drawined off via a trough into grease collection containers at each end of the ventilator. At the end of the cooking day or at scheduled intervals, the cartridges are removed for cleaning without having to climb up or onto the cooking equipment with the use of an extractor removal pot sink. Each cartridge is a maximum of 19-1/2" long. Ventilator can also be quipped with an optional fusible link or thermostatically activated fire damper assembly.

Make-Up Air (Front Face Register Discharge)

Ventilator shall have air registers along front face for discharge of tempered make-up air. Supply volume is 80%, or designed to the desired air balance.

Application

Wall mounted canopy style for use over all types of cooking equipment where integral make-up air is required.

Light Fixtures

All light fixtures shall be pre-wired to a single connection point. Ventilators built in multiple sections to be furnished with junction boxes for ease of field connection by the electrical trades. Light bulbs furnished and installed by the Kitchen Equipment Contractor.

Exhaust Fans

Exhaust fans are to be provided and installed by others in compliance with local codes. **Fans should be induced draft, squirrel cage design, equipped with backward inclined blades.**

Fire Protection

NFPA 96 and local codes require a fire extinguishing system for protection of the duct collar and plenum of all ventilators, as well as for the protection of various cooking appliances such as deep fat fryers, griddles, ranges, and broilers, which may be a source of ignition of grease. Consult factory and local fire officials for exact requirements. UL Listed fire protection systems may be pre-piped by Caddy at the time of manufacture, assuring concealment of piping and detectors.

Approvals

Ventilator shall be UL Listed, listed by NSF and be in accordance with all of the recommendations set forth by NFPA 96. All ventilators must meet all applicable codes.



MODEL:

SHC-C-W-AA---

ADD THE OVERALL LENGTH (IN INCHES) OF THE VENTILATOR AFTER MODEL DESIGNATION

DAMPER TYPE
ND - NO DAMPER
FL - FUSIBLE LINK
T - THERMOSTAT

ADD THE OVERALL WIDTH (IN INCHES) OF THE VENTILATOR AFTER MODEL DESIGNATION

X
EXHAUST DUCT COLLAR LOCATED IN CENTER OR AT ANY POINT ALONG LENGTH OF THE PLENUM

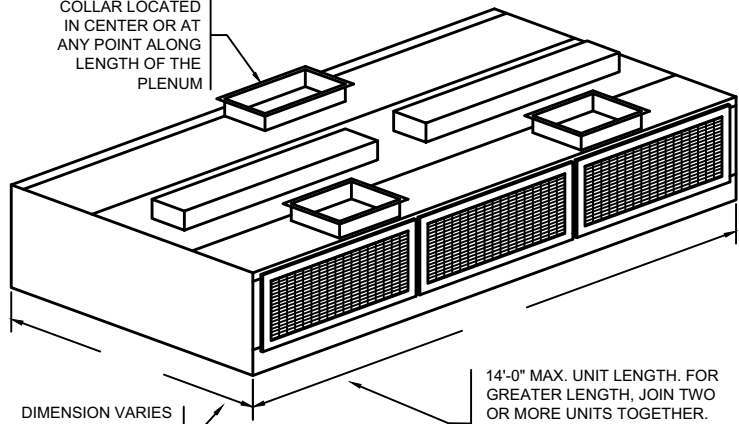

14'-0" MAX. UNIT LENGTH. FOR GREATER LENGTH, JOIN TWO OR MORE UNITS TOGETHER. ALLOW 6" MIN. OVERHANG AT EACH END. IF CHARBROILER IS AT END, OVERHANG 12"

DIMENSION VARIES WITH DEPTH OF THE EQUIPMENT AND REQUIRED OVERHANG

STANDARD LIGHT FIXTURES
 100 WATT INCANDESCENT
 RECESSED INCANDESCENT
 RECESSED FLUORESCENT
 (IF RECESSED FLUORESCENT SPECIFY SIZE)

CONSULT FACTORY FOR NON-STANDARD HEIGHTS
 12" MIN. FRONT OVERHANG
 6" MIN. SIDE OVERHANG (12" MIN. SIDE OVERHANG FOR CHARBROILER)

ITEM #	_____
EST. WEIGHT	_____
LENGTH	_____
WIDTH	_____
HEIGHT	_____
EXHAUST-CFM	_____
DUCT SIZE	_____
S.P.	_____

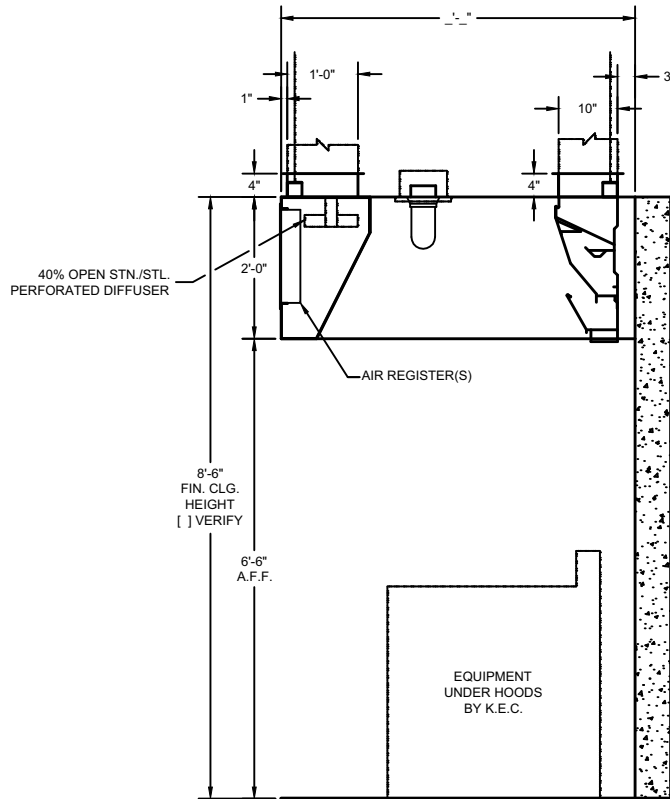

SECTION

DRAWINGS NOT TO SCALE

ENGINEERING DATA

Ventilator Length

Maximum ventilator length in a single section is 14'-0". For lengths greater than 14'-0", join two or more sections. Verify access conditions into building and kitchen space prior to length selection.

Ventilator Hanging Weight

Wt./ lineal ft.	Lbs.	90
-----------------	------	----

NOTE: Refer to **CADDY AirSystems**

Master Engineering Data Sheet in engineering data section for determining light, medium, and heavy duty cooking equipment, C.F.M. requirements (exhaust and supply), duct collar sizes and static pressure requirements.

Electrical Requirements

Light fixtures to be powered by a 120/1/60 circuit.

Mechanical Requirements

The volume of exhaust required is a function of the type of cooking equipment served by the ventilator, and the type and volume of product cooked. Refer to the **CADDY AirSystems**

Master Engineering Data Chart to determine exhaust volume, duct collar sizes, static pressure drop.



Model SHC-C-W-ASII Dry Cartridge Ventilator

ITEM NO:

PROJECT:

LOCATION:

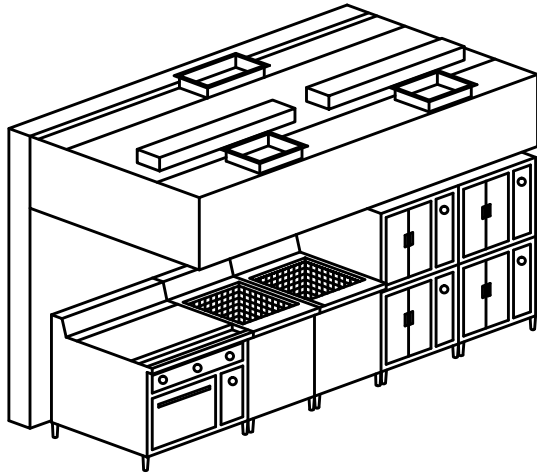

General Specifications

Furnish CADDY *AirSystems* Exhaust Hood Model **SHC-C-W-ASII** as shown on the plans and as described in the following specifications.

General

Exhaust Ventilator shall be constructed of 18 gauge type 300 series stainless steel. All exposed surfaces to have a #4 finish. Construction to meet all requirements of NFPA 96 and NSF Standard No. 2. To include necessary hanger brackets at front and rear suspending from building overhead structure.

Description

The CADDY *AirSystems* Model "SHC" Ventilator is a dry extractor cartridge type and is UL listed under the standards as set forth in UL710 "Exhaust Hoods for Commercial Cooking Equipment." This ventilator is 95% grease extraction efficient when operated and maintained in accordance with design specifications. This high efficiency is accomplished by utilizing removable stainless steel extractor cartridges containing a series of horizontal, self-draining baffles. As the air is drawn around the baffles, the grease, dust and lint particles are slung from the air stream by centrifugal force. As the liquefied grease is extracted, it is drawn off via a trough into grease collection containers at each end of the ventilator. At the end of the cooking day or at scheduled intervals, the cartridges are removed for cleaning without having to climb up or onto the cooking equipment with the use of an extractor removal pot sink. Each cartridge is a maximum of 19-1/2" long. Ventilator can also be quipped with an optional fusible link or thermostatically activated fire damper assembly.

Make-Up Air (Perimeter Down Discharge)

Ventilator shall have air registers along perimeter for down discharge of tempered make-up. Supply volume is 80% or designed to the desired air balance.

Application

Wall mounted canopy style for use over all types of cooking equipment where integral make-up air is required.

Light Fixtures

All light fixtures shall be pre-wired to a single connection point. Ventilators built in multiple sections to be furnished with junction boxes for ease of field connection by the electrical trades. Light bulbs furnished and installed by the Kitchen Equipment Contractor.

Exhaust Fans

Exhaust fans are to be provided and installed by others in compliance with local codes. **Fans should be induced draft, squirrel cage design, equipped with backward inclined blades.**

Fire Protection

NFPA 96 and local codes require a fire extinguishing system for protection of the duct collar and plenum of all ventilators, as well as for the protection of various cooking appliances such as deep fat fryers, griddles, ranges, and broilers, which may be a source of ignition of grease. Consult factory and local fire officials for exact requirements. UL Listed fire protection systems may be pre-piped by Caddy at the time of manufacture, assuring concealment of piping and detectors.

Approvals

Ventilator shall be UL Listed, listed by NSF and be in accordance with all of the recommendations set forth by NFPA 96. All ventilators must meet all applicable codes.



MODEL:

SHC-C-W-ASII---

ADD THE OVERALL LENGTH (IN INCHES) OF THE VENTILATOR AFTER MODEL DESIGNATION

DAMPER TYPE
ND - NO DAMPER
FL - FUSIBLE LINK
T - THERMOSTAT

ADD THE OVERALL WIDTH (IN INCHES) OF THE VENTILATOR AFTER MODEL DESIGNATION

X
EXHAUST DUCT COLLAR LOCATED IN CENTER OR AT ANY POINT ALONG LENGTH OF THE PLENUM

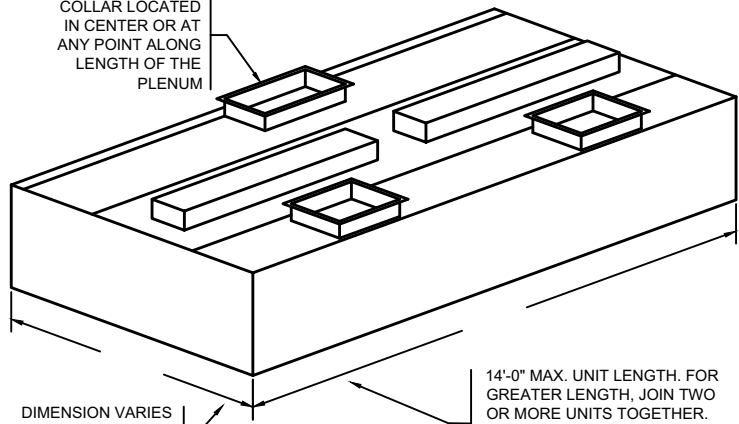

14'-0" MAX. UNIT LENGTH. FOR GREATER LENGTH, JOIN TWO OR MORE UNITS TOGETHER. ALLOW 6" MIN. OVERHANG AT EACH END. IF CHARBROILER IS AT END, OVERHANG 12"

DIMENSION VARIES WITH DEPTH OF THE EQUIPMENT AND REQUIRED OVERHANG

STANDARD LIGHT FIXTURES
 100 WATT INCANDESCENT
 RECESSED INCANDESCENT
 RECESSED FLUORESCENT
 (IF RECESSED FLUORESCENT SPECIFY SIZE)

CONSULT FACTORY FOR NON-STANDARD HEIGHTS
 22" MIN. FRONT OVERHANG
 6" MIN. SIDE OVERHANG
 (12" MIN. SIDE OVERHANG FOR CHARBROILER)

ITEM #	_____
EST. WEIGHT	_____
LENGTH	_____
WIDTH	_____
HEIGHT	_____
EXHAUST-CFM	_____
DUCT SIZE	_____
S.P.	_____

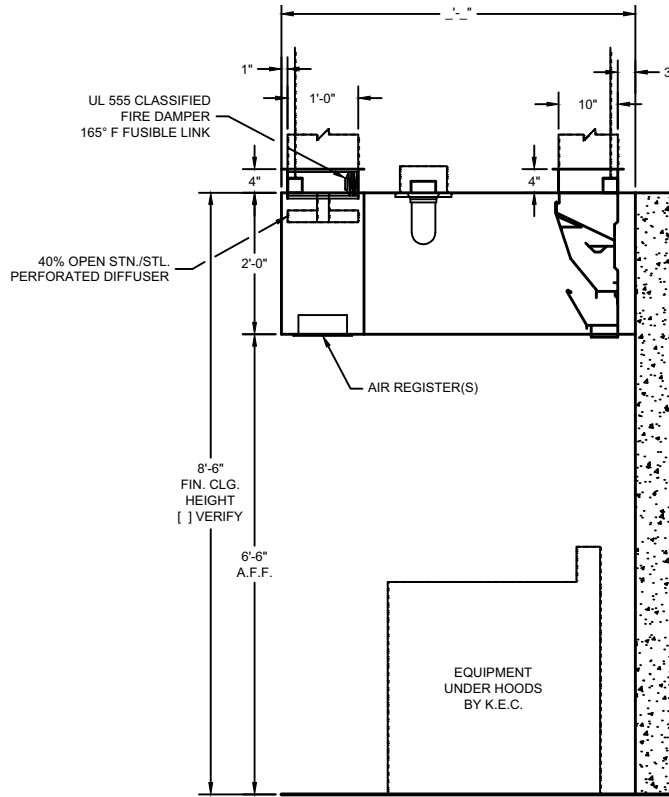

SECTION

DRAWINGS NOT TO SCALE

ENGINEERING DATA

Ventilator Length

Maximum ventilator length in a single section is 14'-0". For lengths greater than 14'-0", join two or more sections. Verify access conditions into building and kitchen space prior to length selection.

Ventilator Hanging Weight

Wt./ lineal ft.	Lbs.	90
-----------------	------	----

NOTE: Refer to CADDY AirSystems

Master Engineering Data Sheet in engineering data section for determining light, medium, and heavy duty cooking equipment, C.F.M. requirements (exhaust and supply), duct collar sizes and static pressure requirements.

Electrical Requirements

Light fixtures to be powered by a 120/1/60 circuit.

Mechanical Requirements

The volume of exhaust required is a function of the type of cooking equipment served by the ventilator, and the type and volume of product cooked. Refer to the CADDY AirSystems

Master Engineering Data Chart to determine exhaust volume, duct collar sizes, static pressure drop.



Model SHC-C-W

Dry Cartridge Ventilator With Ceiling Supply Plenum

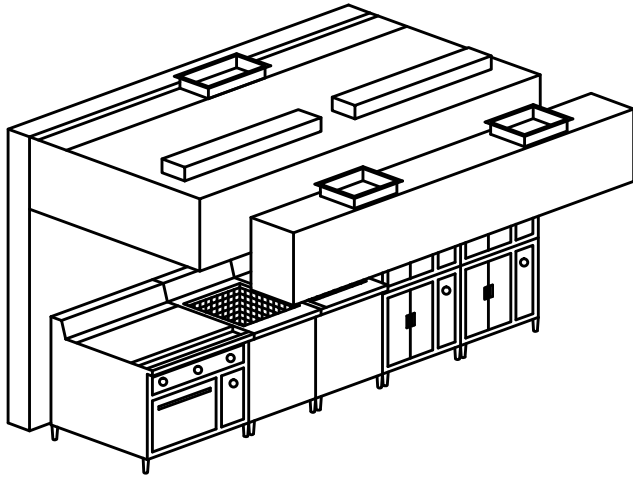

General Specifications

Furnish CADDY *AirSystems* Exhaust Hood Model **SHC-C-W-ASII** as shown on the plans and as described in the following specifications.

General

Exhaust Ventilator shall be constructed of 18 gauge type 300 series stainless steel. All exposed surfaces to have a #4 finish. Construction to meet all requirements of NFPA 96 and NSF Standard No. 2. To include necessary hanger brackets at front and rear suspending from building overhead structure.

Description

The CADDY *AirSystems* Model "SHC" Ventilator is a dry extractor cartridge type and is UL listed under the standards as set forth in UL710 "Exhaust Hoods for Commercial Cooking Equipment." This ventilator is 95% grease extraction efficient when operated and maintained in accordance with design specifications. This high efficiency is accomplished by utilizing removable stainless steel extractor cartridges containing a series of horizontal, self-draining baffles. As the air is drawn around the baffles, the grease, dust and lint particles are slung from the air stream by centrifugal force. As the liquefied grease is extracted, it is drawn off via a trough into grease collection containers at each end of the ventilator. At the end of the cooking day or at scheduled intervals, the cartridges are removed for cleaning without having to climb up or onto the cooking equipment with the use of an extractor removal pot sink. Each cartridge is a maximum of 19-1/2" long. Ventilator can also be equipped with an optional fusible link or thermostatically activated fire damper assembly.

Make-Up Air (Perimeter Down Discharge)

Ventilator shall have air registers along perimeter for down discharge of tempered make-up. Supply volume is 80% or designed to the desired air balance.

Application

Wall mounted canopy style for use over all types of cooking equipment where integral make-up air is required.

Light Fixtures

All light fixtures shall be pre-wired to a single connection point. Ventilators built in multiple sections to be furnished with junction boxes for ease of field connection by the electrical trades. Light bulbs furnished and installed by the Kitchen Equipment Contractor.

Exhaust Fans

Exhaust fans are to be provided and installed by others in compliance with local codes. **Fans should be induced draft, squirrel cage design, equipped with backward inclined blades.**

Fire Protection

NFPA 96 and local codes require a fire extinguishing system for protection of the duct collar and plenum of all ventilators, as well as for the protection of various cooking appliances such as deep fat fryers, griddles, ranges, and broilers, which may be a source of ignition of grease. Consult factory and local fire officials for exact requirements. UL Listed fire protection systems may be pre-piped by Caddy at the time of manufacture, assuring concealment of piping and detectors.

Approvals

Ventilator shall be UL Listed, listed by NSF and be in accordance with all of the recommendations set forth by NFPA 96. All ventilators must meet all applicable codes.



MODEL:

SHC-C-W- [] - [] - []

ADD THE OVERALL LENGTH (IN INCHES) OF THE VENTILATOR AFTER MODEL DESIGNATION

DAMPER TYPE
ND - NO DAMPER
FL - FUSIBLE LINK
T - THERMOSTAT

ADD THE OVERALL WIDTH (IN INCHES) OF THE VENTILATOR AFTER MODEL DESIGNATION

X
EXHAUST DUCT COLLAR LOCATED IN CENTER OR AT ANY POINT ALONG LENGTH OF THE PLENUM

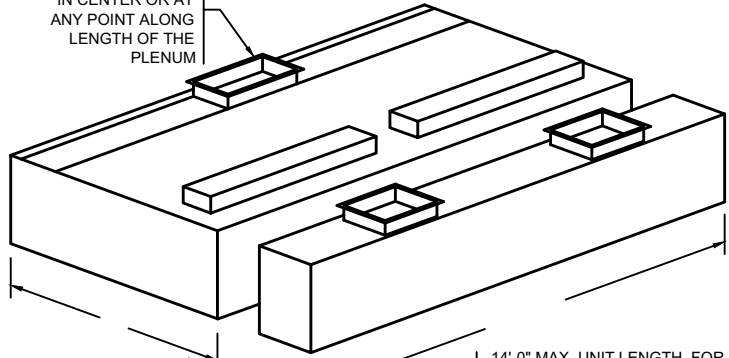

14'-0" MAX. UNIT LENGTH. FOR GREATER LENGTH, JOIN TWO OR MORE UNITS TOGETHER. ALLOW 6" MIN. OVERHANG AT EACH END. IF CHARBROILER IS AT END, OVERHANG 12"

DIMENSION VARIES WITH DEPTH OF THE EQUIPMENT AND REQUIRED OVERHANG

STANDARD LIGHT FIXTURES
 100 WATT INCANDESCENT
 RECESSED INCANDESCENT
 RECESSED FLUORESCENT
 (IF RECESSED FLUORESCENT SPECIFY SIZE)

CONSULT FACTORY FOR NON-STANDARD HEIGHTS
 22" MIN. FRONT OVERHANG
 6" MIN. SIDE OVERHANG
 (12" MIN. SIDE OVERHANG FOR CHARBROILER)

ITEM # _____
 EST. WEIGHT _____
 LENGTH _____
 WIDTH _____
 HEIGHT _____
 EXHAUST-CFM _____
 DUCT SIZE _____
 S.P. _____

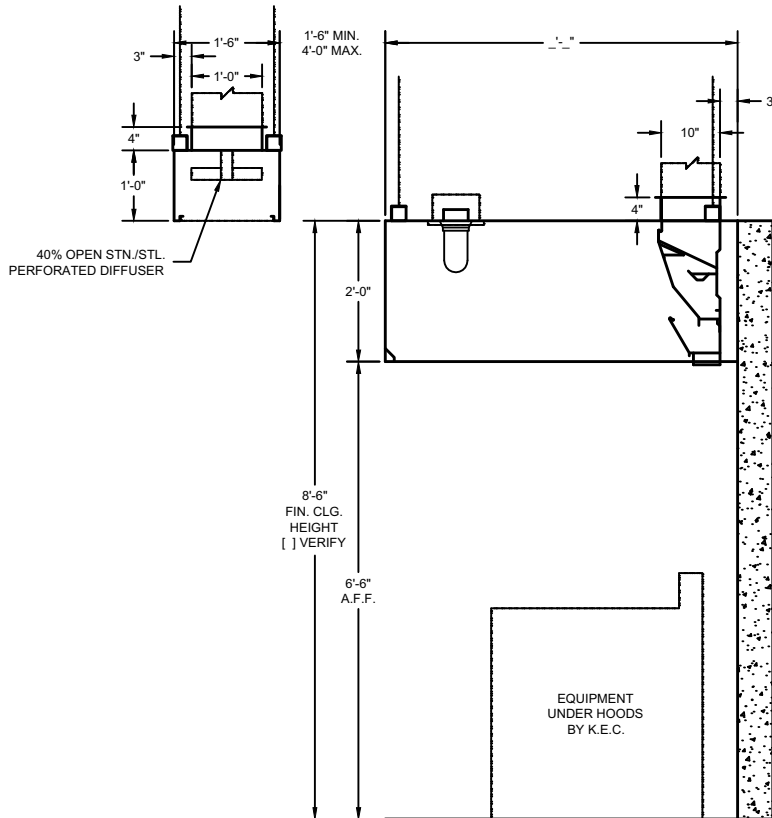

DRAWINGS NOT TO SCALE

ENGINEERING DATA

Ventilator Length

Maximum ventilator length in a single section is 14'-0". For lengths greater than 14'-0", join two or more sections. Verify access conditions into building and kitchen space prior to length selection.

Ventilator Hanging Weight

Wt./ lineal ft.	Lbs.	90
-----------------	------	----

NOTE: Refer to CADDY AirSystems

Master Engineering Data Sheet in engineering data section for determining light, medium, and heavy duty cooking equipment, C.F.M. requirements (exhaust and supply), duct collar sizes and static pressure requirements.

Electrical Requirements

Light fixtures to be powered by a 120/1/60 circuit.

Mechanical Requirements

The volume of exhaust required is a function of the type of cooking equipment served by the ventilator, and the type and volume of product cooked. Refer to the **CADDY AirSystems**

Master Engineering Data Chart to determine exhaust volume, duct collar sizes, static pressure drop.





CADDY CORPORATION

Food Service Equipment

Air Systems

Commercial Kitchen Exhaust Systems

Model SHC
Single Island Style

Model SHC-C-I

Dry Cartridge Ventilator

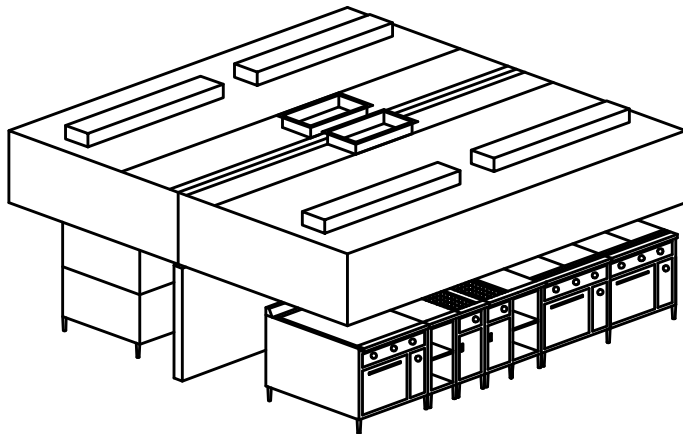

General Specifications

Furnish CADDY *AirSystems* Exhaust Hood Model **SHC-C-I** as shown on the plans and as described in the following specifications.

General

Exhaust Ventilator shall be constructed of 18 gauge type 300 series stainless steel. All exposed surfaces to have a #4 finish. Construction to meet all requirements of NFPA 96 and NSF Standard No. 2. To include necessary hanger brackets at front and rear suspending from building overhead structure.

Description

The CADDY *AirSystems* Model "SHC" Ventilator is a dry extractor cartridge type and is UL listed under the standards as set forth in UL710 "Exhaust Hoods for Commercial Cooking Equipment." This ventilator is 95% grease extraction efficient when operated and maintained in accordance with design specifications. This high efficiency is accomplished by utilizing removable stainless steel extractor cartridges containing a series of horizontal, self-draining baffles. As the air is drawn around the baffles, the grease, dust and lint particles are slung from the air stream by centrifugal force. As the liquefied grease is extracted, it is drawn off via a trough into grease collection containers at each end of the ventilator. At the end of the cooking day or at scheduled intervals, the cartridges are removed for cleaning without having to climb up or onto the cooking equipment with the use of an extractor removal pot sink. Each cartridge is a maximum of 19-1/2" long. Ventilator can also be quipped with an optional fusible link or thermostatically activated fire damper assembly.

Application

Island mounted exhaust-only canopy style for use over all types of cooking equipment.

Light Fixtures

All light fixtures shall be pre-wired to a single connection point. Ventilators built in multiple sections to be furnished with junction boxes for ease of field connection by the electrical trades. Light bulbs furnished and installed by the Kitchen Equipment Contractor.

Exhaust Fans

Exhaust fans are to be provided and installed by others in compliance with local codes. **Fans should be induced draft, squirrel cage design, equipped with backward inclined blades.**

Fire Protection

NFPA 96 and local codes require a fire extinguishing system for protection of the duct collar and plenum of all ventilators, as well as for the protection of various cooking appliances such as deep fat fryers, griddles, ranges, and broilers, which may be a source of ignition of grease. Consult factory and local fire officials for exact requirements. UL Listed fire protection systems may be pre-piped by Caddy at the time of manufacture, assuring concealment of piping and detectors.

Approvals

Ventilator shall be UL Listed, listed by NSF and be in accordance with all of the recommendations set forth by NFPA 96. All ventilators must meet all applicable codes.



MODEL:

SHC-C-I---

ADD THE OVERALL LENGTH (IN INCHES) OF THE VENTILATOR AFTER MODEL DESIGNATION

DAMPER TYPE
ND - NO DAMPER
FL - FUSIBLE LINK
T - THERMOSTAT

ADD THE OVERALL WIDTH (IN INCHES) OF THE VENTILATOR AFTER MODEL DESIGNATION

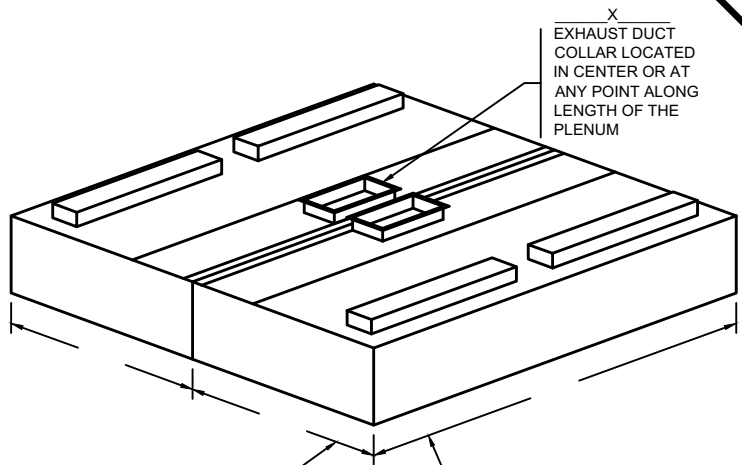

X
EXHAUST DUCT COLLAR LOCATED IN CENTER OR AT ANY POINT ALONG LENGTH OF THE PLENUM

DIMENSION VARIES WITH DEPTH OF THE EQUIPMENT AND REQUIRED OVERHANG

14'-0" MAX. UNIT LENGTH. FOR GREATER LENGTH, JOIN TWO OR MORE UNITS TOGETHER. ALLOW 6" MIN. OVERHANG AT EACH END. IF CHARBROILER IS AT END, OVERHANG 12"

STANDARD LIGHT FIXTURES
 100 WATT INCANDESCENT
 RECESSED INCANDESCENT
 RECESSED FLUORESCENT
 (IF RECESSED FLUORESCENT SPECIFY SIZE)

CONSULT FACTORY FOR NON-STANDARD HEIGHTS
 12" MIN. FRONT OVERHANG
 6" MIN. SIDE OVERHANG
 (12" MIN. SIDE OVERHANG FOR CHARBROILER)

ITEM # _____
 EST. WEIGHT _____
 LENGTH _____
 WIDTH _____
 HEIGHT _____
 EXHAUST-CFM _____
 DUCT SIZE _____
 S.P. _____

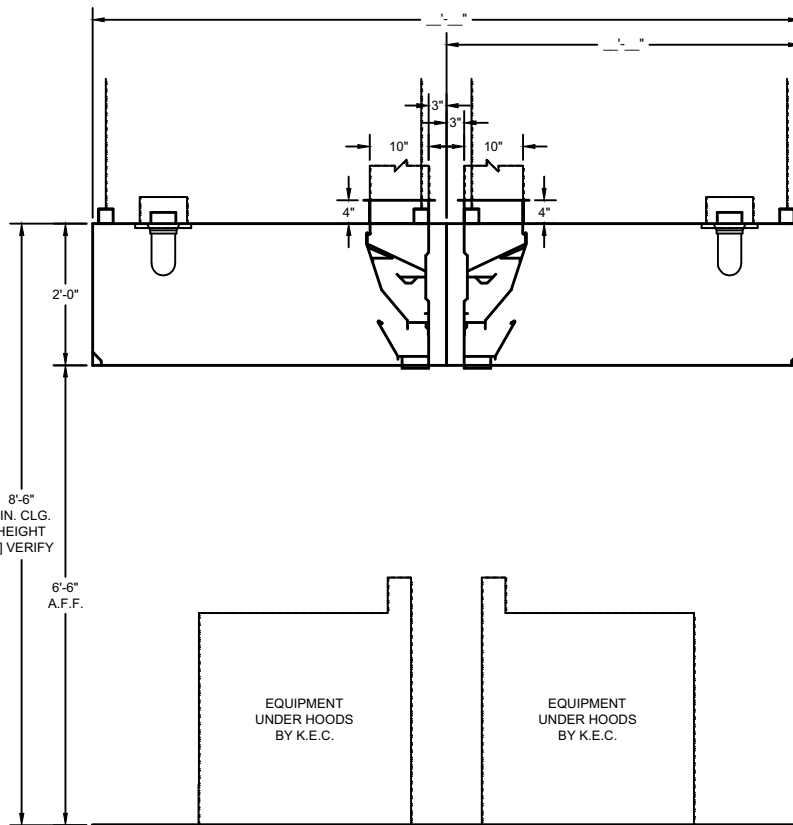

EQUIPMENT UNDER HOODS BY K.E.C.

SECTION

DRAWINGS NOT TO SCALE

ENGINEERING DATA

Ventilator Length

Maximum ventilator length in a single section is 14'-0". For lengths greater than 14'-0", join two or more sections. Verify access conditions into building and kitchen space prior to length selection.

Ventilator Hanging Weight

Wt./ lineal ft. Lbs. 75

NOTE: Refer to **CADDY AirSystems**

Master Engineering Data Sheet in engineering data section for determining light, medium, and heavy duty cooking equipment, C.F.M. requirements (exhaust and supply), duct collar sizes and static pressure requirements.

Electrical Requirements

Light fixtures to be powered by a 120/1/60 circuit.

Mechanical Requirements

The volume of exhaust required is a function of the type of cooking equipment served by the ventilator, and the type and volume of product cooked. Refer to the **CADDY AirSystems**

Master Engineering Data Chart to determine exhaust volume, duct collar sizes, static pressure drop.



Model SHC-C-I-PA Dry Cartridge Ventilator

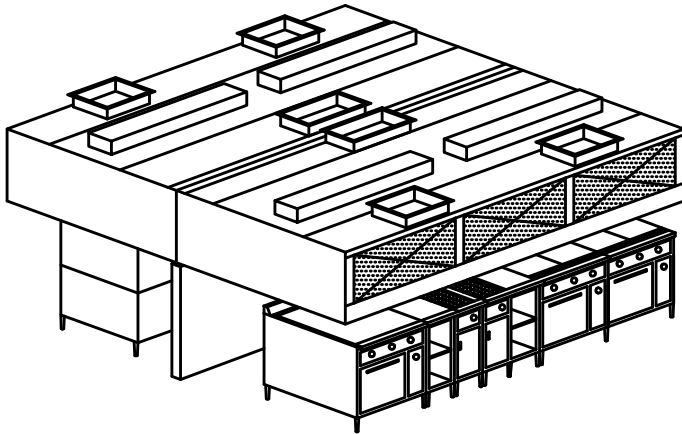

General Specifications

Furnish CADDY *AirSystems* Exhaust Hood Model **SHC-C-I-PA** as shown on the plans and as described in the following specifications.

General

Exhaust Ventilator shall be constructed of 18 gauge type 300 series stainless steel. All exposed surfaces to have a #4 finish. Construction to meet all requirements of NFPA 96 and NSF Standard No. 2. To include necessary hanger brackets at front and rear suspending from building overhead structure.

Description

The CADDY *AirSystems* Model "SHC" Ventilator is a dry extractor cartridge type and is UL listed under the standards as set forth in UL710 "Exhaust Hoods for Commercial Cooking Equipment." This ventilator is 95% grease extraction efficient when operated and maintained in accordance with design specifications. This high efficiency is accomplished by utilizing removable stainless steel extractor cartridges containing a series of horizontal, self-draining baffles. As the air is drawn around the baffles, the grease, dust and lint particles are slung from the air stream by centrifugal force. As the liquefied grease is extracted, it is drawined off via a trough into grease collection containers at each end of the ventilator. At the end of the cooking day or at scheduled intervals, the cartridges are removed for cleaning without having to climb up or onto the cooking equipment with the use of an extractor removal pot sink. Each cartridge is a maximum of 19-1/2" long. Ventilator can also be quipped with an optional fusible link or thermostatically activated fire damper assembly.

Make-Up Air (Front Face Discharge)

Ventilator shall have 40% open stainless steel perforated screens along front face for discharge of tempered make-up air. Supply volume is 80% or designed to the desired air balance.

Application

Island style cooking applications for use over all types of cooking equipment where integral make-up air is required.

Light Fixtures

All light fixtures shall be pre-wired to a single connection point. Ventilators built in multiple sections to be furnished with junction boxes for ease of field connection by the electrical trades. Light bulbs furnished and installed by the Kitchen Equipment Contractor.

Exhaust Fans

Exhaust fans are to be provided and installed by others in compliance with local codes. **Fans should be induced draft, squirrel cage design, equipped with backward inclined blades.**

Fire Protection

NFPA 96 and local codes require a fire extinguishing system for protection of the duct collar and plenum of all ventilators, as well as for the protection of various cooking appliances such as deep fat fryers, griddles, ranges, and broilers, which may be a source of ignition of grease. Consult factory and local fire officials for exact requirements. UL Listed fire protection systems may be pre-piped by Caddy at the time of manufacture, assuring concealment of piping and detectors.

Approvals

Ventilator shall be UL Listed, listed by NSF and be in accordance with all of the recommendations set forth by NFPA 96. All ventilators must meet all applicable codes.



MODEL:

SHC-C-I-PA---

ADD THE OVERALL LENGTH (IN INCHES) OF THE VENTILATOR AFTER MODEL DESIGNATION

DAMPER TYPE
ND - NO DAMPER
FL - FUSIBLE LINK
T - THERMOSTAT

ADD THE OVERALL WIDTH (IN INCHES) OF THE VENTILATOR AFTER MODEL DESIGNATION

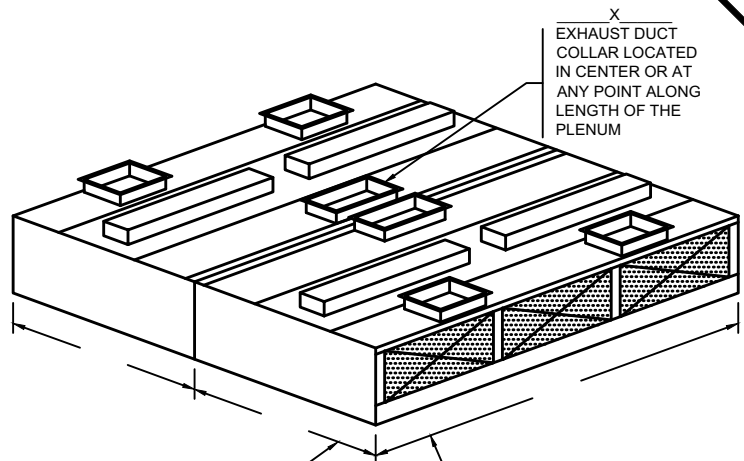

X
EXHAUST DUCT COLLAR LOCATED IN CENTER OR AT ANY POINT ALONG LENGTH OF THE PLENUM

DIMENSION VARIES WITH DEPTH OF THE EQUIPMENT AND REQUIRED OVERHANG

14'-0" MAX. UNIT LENGTH. FOR GREATER LENGTH, JOIN TWO OR MORE UNITS TOGETHER. ALLOW 6" MIN. OVERHANG AT EACH END. IF CHARBROILER IS AT END, OVERHANG 12"

STANDARD LIGHT FIXTURES
 100 WATT INCANDESCENT
 RECESSED INCANDESCENT
 RECESSED FLUORESCENT
 (IF RECESSED FLUORESCENT SPECIFY SIZE)

CONSULT FACTORY FOR NON-STANDARD HEIGHTS
 12" MIN. FRONT OVERHANG
 6" MIN. SIDE OVERHANG
 (12" MIN. SIDE OVERHANG FOR CHARBROILER)

ITEM # _____
 EST. WEIGHT _____
 LENGTH _____
 WIDTH _____
 HEIGHT _____
 EXHAUST-CFM _____
 DUCT SIZE _____
 S.P. _____

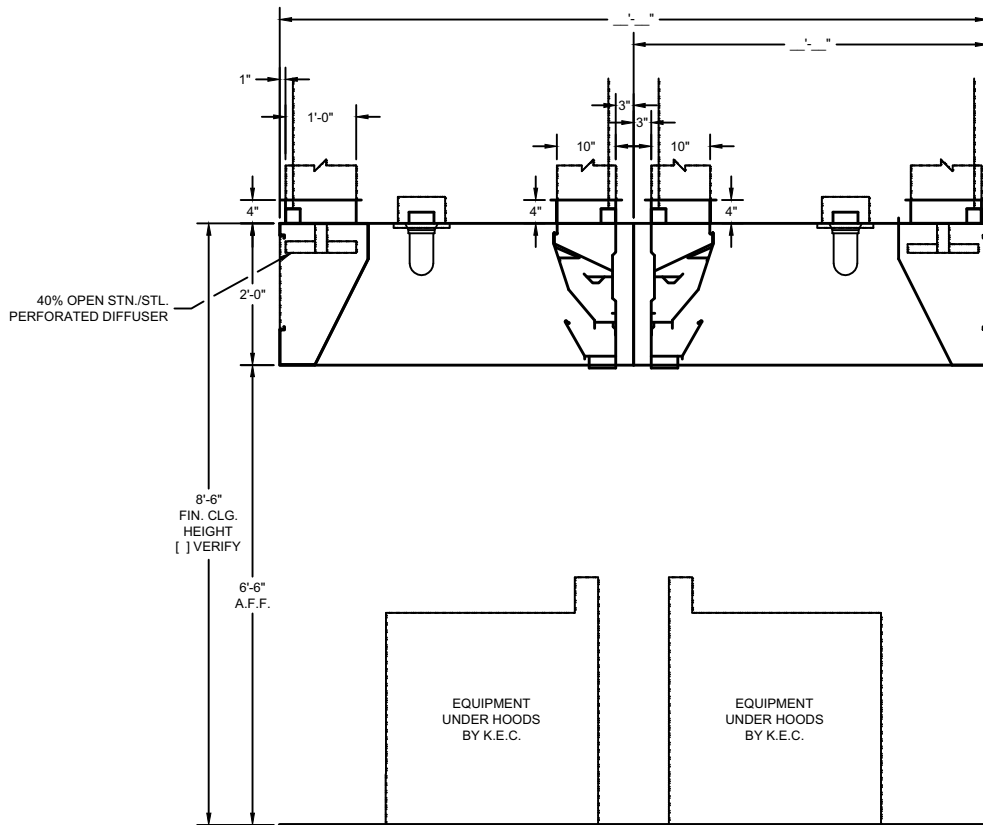

SECTION

DRAWINGS NOT TO SCALE

ENGINEERING DATA

Ventilator Length

Maximum ventilator length in a single section is 14'-0". For lengths greater than 14'-0", join two or more sections. Verify access conditions into building and kitchen space prior to length selection.

Ventilator Hanging Weight

Wt./ lineal ft.	Lbs.	90
-----------------	------	----

NOTE: Refer to CADDY AirSystems

Master Engineering Data Sheet in engineering data section for determining light, medium, and heavy duty cooking equipment, C.F.M. requirements (exhaust and supply), duct collar sizes and static pressure requirements.

Electrical Requirements

Light fixtures to be powered by a 120/1/60 circuit.

Mechanical Requirements

The volume of exhaust required is a function of the type of cooking equipment served by the ventilator, and the type and volume of product cooked. Refer to the **CADDY AirSystems**

Master Engineering Data Chart to determine exhaust volume, duct collar sizes, static pressure drop.



Model SHC-C-I-ASI Dry Cartridge Ventilator

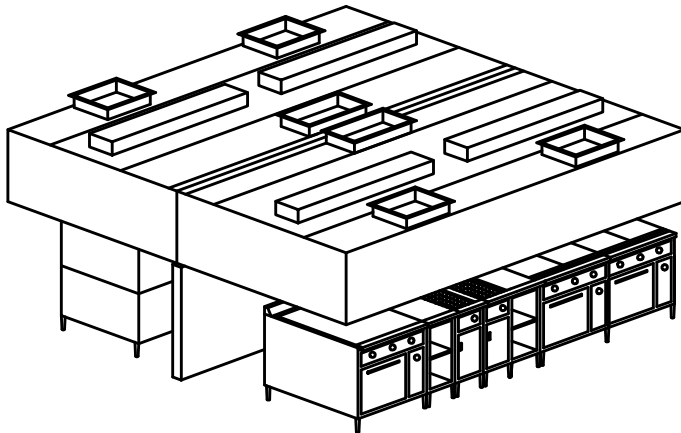

General Specifications

Furnish CADDY *AirSystems* Exhaust Hood Model **SHC-C-I-ASI** as shown on the plans and as described in the following specifications.

General

Exhaust Ventilator shall be constructed of 18 gauge type 300 series stainless steel. All exposed surfaces to have a #4 finish. Construction to meet all requirements of NFPA 96 and NSF Standard No. 2. To include necessary hanger brackets at front and rear suspending from building overhead structure.

Description

The CADDY *AirSystems* Model "SHC" Ventilator is a dry extractor cartridge type and is UL listed under the standards as set forth in UL710 "Exhaust Hoods for Commercial Cooking Equipment." This ventilator is 95% grease extraction efficient when operated and maintained in accordance with design specifications. This high efficiency is accomplished by utilizing removable stainless steel extractor cartridges containing a series of horizontal, self-draining baffles. As the air is drawn around the baffles, the grease, dust and lint particles are slung from the air stream by centrifugal force. As the liquefied grease is extracted, it is drawined off via a trough into grease collection containers at each end of the ventilator. At the end of the cooking day or at scheduled intervals, the cartridges are removed for cleaning without having to climb up or onto the cooking equipment with the use of an extractor removal pot sink. Each cartridge is a maximum of 19-1/2" long. Ventilator can also be quipped with an optional fusible link or thermostatically activated fire damper assembly.

Make-Up Air (Internal Discharge)

Ventilator shall have a fully insulated supply plenum with duct collar/fire damper assemblies and air registers internally mounted for discharging untempered make-up air directly into canopy of ventilator. The amount of make-up air supplied through this design is directly related to the type of cooking equipment located beneath the hood. The percentage of supply air distributed will vary as a function of the thermal currents generated by each individual appliance. When specifying this style, consult factory for specific supply volumes. This air may be untempered in most areas, depending upon climatic conditions and the type of cooking equipment.

Application

Island style cooking applications for use over all types of cooking equipment where integral make-up air is required.

Light Fixtures

All light fixtures shall be pre-wired to a single connection point. Ventilators built in multiple sections to be furnished with junction boxes for ease of field connection by the electrical trades. Light bulbs furnished and installed by the Kitchen Equipment Contractor.

Exhaust Fans

Exhaust fans are to be provided and installed by others in compliance with local codes. **Fans should be induced draft, squirrel cage design, equipped with backward inclined blades.**

Fire Protection

NFPA 96 and local codes require a fire extinguishing system for protection of the duct collar and plenum of all ventilators, as well as for the protection of various cooking appliances such as deep fat fryers, griddles, ranges, and broilers, which may be a source of ignition of grease. Consult factory and local fire officials for exact requirements. UL Listed fire protection systems may be pre-piped by Caddy at the time of manufacture, assuring concealment of piping and detectors.

Approvals

Ventilator shall be UL Listed, listed by NSF and be in accordance with all of the recommendations set forth by NFPA 96. All ventilators must meet all applicable codes.



MODEL:

SHC-C-I-ASI---

ADD THE OVERALL LENGTH (IN INCHES) OF THE VENTILATOR AFTER MODEL DESIGNATION

DAMPER TYPE
ND - NO DAMPER
FL - FUSIBLE LINK
T - THERMOSTAT

ADD THE OVERALL WIDTH (IN INCHES) OF THE VENTILATOR AFTER MODEL DESIGNATION

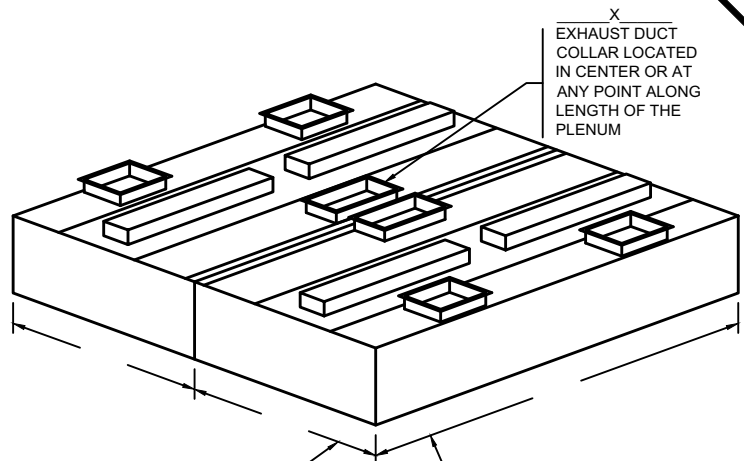

X
EXHAUST DUCT COLLAR LOCATED IN CENTER OR AT ANY POINT ALONG LENGTH OF THE PLENUM

DIMENSION VARIES WITH DEPTH OF THE EQUIPMENT AND REQUIRED OVERHANG

14'-0" MAX. UNIT LENGTH. FOR GREATER LENGTH, JOIN TWO OR MORE UNITS TOGETHER. ALLOW 6" MIN. OVERHANG AT EACH END. IF CHARBROILER IS AT END, OVERHANG 12"

STANDARD LIGHT FIXTURES
 100 WATT INCANDESCENT
 RECESSED INCANDESCENT
 RECESSED FLUORESCENT
 (IF RECESSED FLUORESCENT SPECIFY SIZE)

CONSULT FACTORY FOR NON-STANDARD HEIGHTS
 22" MIN. FRONT OVERHANG
 6" MIN. SIDE OVERHANG (12" MIN. SIDE OVERHANG FOR CHARBROILER)

ITEM #	_____
EST. WEIGHT	_____
LENGTH	_____
WIDTH	_____
HEIGHT	_____
EXHAUST-CFM	_____
DUCT SIZE	_____
S.P.	_____

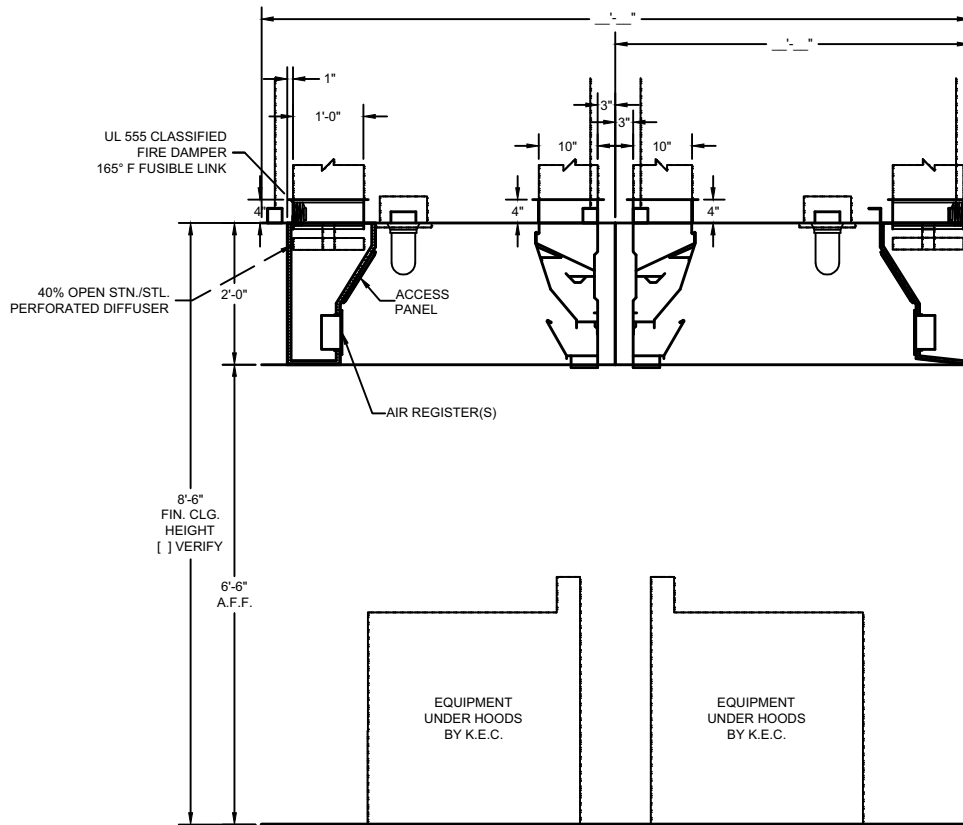

UL 555 CLASSIFIED FIRE DAMPER 165° F FUSIBLE LINK

40% OPEN STN./STL. PERFORATED DIFFUSER

AIR REGISTER(S)

8'-6" FIN. CLG. HEIGHT [] VERIFY

6'-6" A.F.F.

EQUIPMENT UNDER HOODS BY K.E.C.

EQUIPMENT UNDER HOODS BY K.E.C.

SECTION

DRAWINGS NOT TO SCALE

ENGINEERING DATA

Ventilator Length

Maximum ventilator length in a single section is 14'-0". For lengths greater than 14'-0", join two or more sections. Verify access conditions into building and kitchen space prior to length selection.

Ventilator Hanging Weight

Wt./ lineal ft.	Lbs.	90
-----------------	------	----

NOTE: Refer to CADDY AirSystems

Master Engineering Data Sheet in engineering data section for determining light, medium, and heavy duty cooking equipment, C.F.M. requirements (exhaust and supply), duct collar sizes and static pressure requirements.

Electrical Requirements

Light fixtures to be powered by a 120/1/60 circuit.

Mechanical Requirements

The volume of exhaust required is a function of the type of cooking equipment served by the ventilator, and the type and volume of product cooked. Refer to the **CADDY AirSystems**

Master Engineering Data Chart to determine exhaust volume, duct collar sizes, static pressure drop.



Model SHC-C-I-AA Dry Cartridge Ventilator

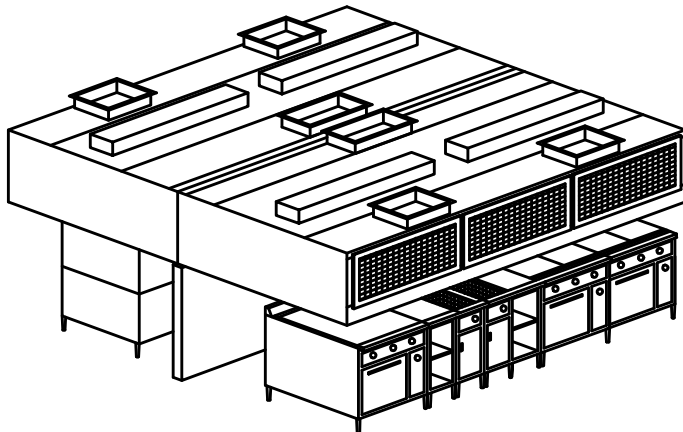

General Specifications

Furnish CADDY *AirSystems* Exhaust Hood Model **SHC-C-I-AA** as shown on the plans and as described in the following specifications.

General

Exhaust Ventilator shall be constructed of 18 gauge type 300 series stainless steel. All exposed surfaces to have a #4 finish. Construction to meet all requirements of NFPA 96 and NSF Standard No. 2. To include necessary hanger brackets at front and rear suspending from building overhead structure.

Description

The CADDY *AirSystems* Model "SHC" Ventilator is a dry extractor cartridge type and is UL listed under the standards as set forth in UL710 "Exhaust Hoods for Commercial Cooking Equipment." This ventilator is 95% grease extraction efficient when operated and maintained in accordance with design specifications. This high efficiency is accomplished by utilizing removable stainless steel extractor cartridges containing a series of horizontal, self-draining baffles. As the air is drawn around the baffles, the grease, dust and lint particles are slung from the air stream by centrifugal force. As the liquefied grease is extracted, it is drawn off via a trough into grease collection containers at each end of the ventilator. At the end of the cooking day or at scheduled intervals, the cartridges are removed for cleaning without having to climb up or onto the cooking equipment with the use of an extractor removal pot sink. Each cartridge is a maximum of 19-1/2" long. Ventilator can also be quipped with an optional fusible link or thermostatically activated fire damper assembly.

Make-Up Air (Front Face Register Discharge)

Ventilator shall have air registers along front face for discharge of tempered make-up air. Supply volume is 80%, or designed to the desired air balance.

Application

Island style cooking applications for use over all types of cooking equipment where integral make-up air is required.

Light Fixtures

All light fixtures shall be pre-wired to a single connection point. Ventilators built in multiple sections to be furnished with junction boxes for ease of field connection by the electrical trades. Light bulbs furnished and installed by the Kitchen Equipment Contractor.

Exhaust Fans

Exhaust fans are to be provided and installed by others in compliance with local codes. **Fans should be induced draft, squirrel cage design, equipped with backward inclined blades.**

Fire Protection

NFPA 96 and local codes require a fire extinguishing system for protection of the duct collar and plenum of all ventilators, as well as for the protection of various cooking appliances such as deep fat fryers, griddles, ranges, and broilers, which may be a source of ignition of grease. Consult factory and local fire officials for exact requirements. UL Listed fire protection systems may be pre-piped by Caddy at the time of manufacture, assuring concealment of piping and detectors.

Approvals

Ventilator shall be UL Listed, listed by NSF and be in accordance with all of the recommendations set forth by NFPA 96. All ventilators must meet all applicable codes.



MODEL:

SHC-C-I-AA---

ADD THE OVERALL LENGTH (IN INCHES) OF THE VENTILATOR AFTER MODEL DESIGNATION

DAMPER TYPE
ND - NO DAMPER
FL - FUSIBLE LINK
T - THERMOSTAT

ADD THE OVERALL WIDTH (IN INCHES) OF THE VENTILATOR AFTER MODEL DESIGNATION

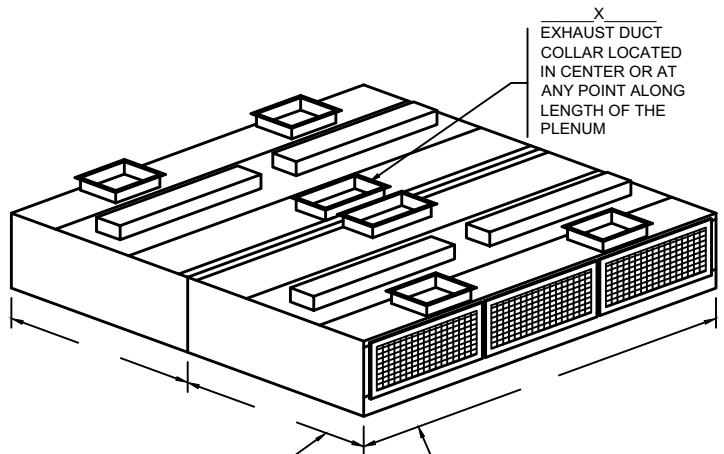

X
EXHAUST DUCT COLLAR LOCATED IN CENTER OR AT ANY POINT ALONG LENGTH OF THE PLENUM

DIMENSION VARIES WITH DEPTH OF THE EQUIPMENT AND REQUIRED OVERHANG

14'-0" MAX. UNIT LENGTH. FOR GREATER LENGTH, JOIN TWO OR MORE UNITS TOGETHER. ALLOW 6" MIN. OVERHANG AT EACH END. IF CHARBROILER IS AT END, OVERHANG 12"

STANDARD LIGHT FIXTURES
 100 WATT INCANDESCENT
 RECESSED INCANDESCENT
 RECESSED FLUORESCENT
 (IF RECESSED FLUORESCENT SPECIFY SIZE)

CONSULT FACTORY FOR NON-STANDARD HEIGHTS
 12" MIN. FRONT OVERHANG
 6" MIN. SIDE OVERHANG
 (12" MIN. SIDE OVERHANG FOR CHARBROILER)

ITEM # _____
 EST. WEIGHT _____
 LENGTH _____
 WIDTH _____
 HEIGHT _____
 EXHAUST-CFM _____
 DUCT SIZE _____
 S.P. _____

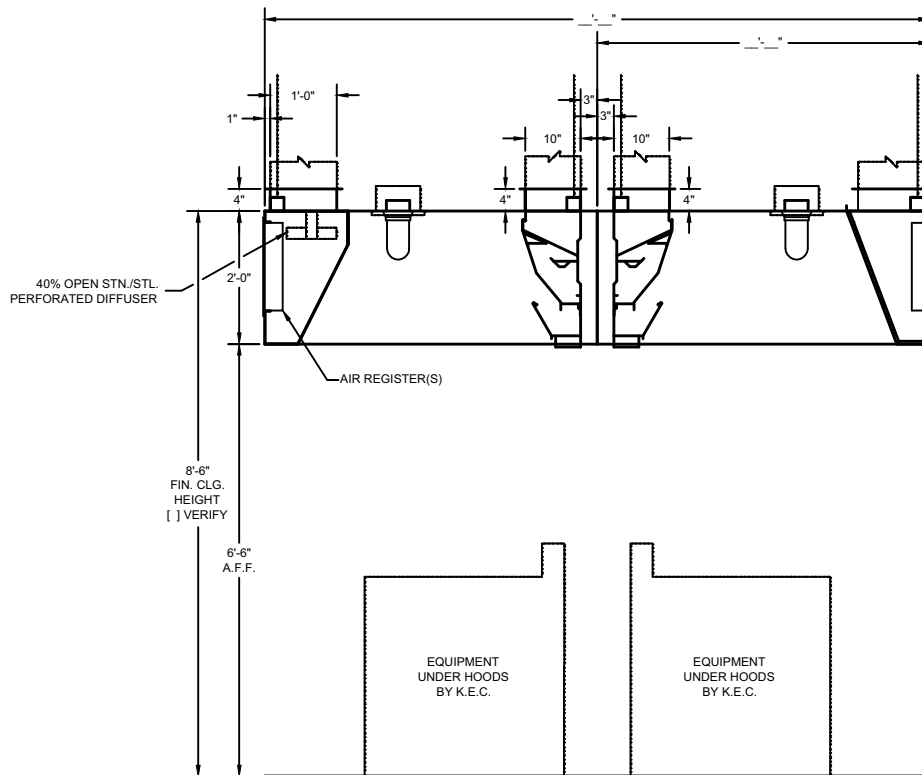

SECTION

DRAWINGS NOT TO SCALE

ENGINEERING DATA

Ventilator Length

Maximum ventilator length in a single section is 14'-0". For lengths greater than 14'-0", join two or more sections. Verify access conditions into building and kitchen space prior to length selection.

Ventilator Hanging Weight

Wt./ lineal ft.	Lbs.	90
-----------------	------	----

NOTE: Refer to CADDY AirSystems

Master Engineering Data Sheet in engineering data section for determining light, medium, and heavy duty cooking equipment, C.F.M. requirements (exhaust and supply), duct collar sizes and static pressure requirements.

Electrical Requirements

Light fixtures to be powered by a 120/1/60 circuit.

Mechanical Requirements

The volume of exhaust required is a function of the type of cooking equipment served by the ventilator, and the type and volume of product cooked. Refer to the CADDY AirSystems

Master Engineering Data Chart to determine exhaust volume, duct collar sizes, static pressure drop.



Model SHC-C-I-ASII

Dry Cartridge Ventilator

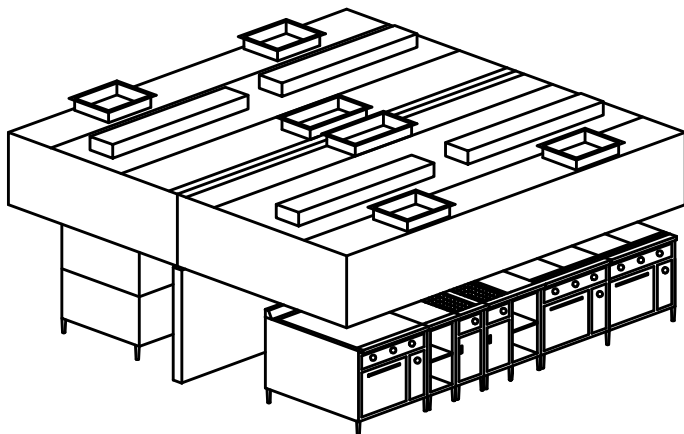

General Specifications

Furnish CADDY *AirSystems* Exhaust Hood Model **SHC-C-I-ASII** as shown on the plans and as described in the following specifications.

General

Exhaust Ventilator shall be constructed of 18 gauge type 300 series stainless steel. All exposed surfaces to have a #4 finish. Construction to meet all requirements of NFPA 96 and NSF Standard No. 2. To include necessary hanger brackets at front and rear suspending from building overhead structure.

Description

The CADDY *AirSystems* Model "SHC" Ventilator is a dry extractor cartridge type and is UL listed under the standards as set forth in UL710 "Exhaust Hoods for Commercial Cooking Equipment." This ventilator is 95% grease extraction efficient when operated and maintained in accordance with design specifications. This high efficiency is accomplished by utilizing removable stainless steel extractor cartridges containing a series of horizontal, self-draining baffles. As the air is drawn around the baffles, the grease, dust and lint particles are slung from the air stream by centrifugal force. As the liquefied grease is extracted, it is drawined off via a trough into grease collection containers at each end of the ventilator. At the end of the cooking day or at scheduled intervals, the cartridges are removed for cleaning without having to climb up or onto the cooking equipment with the use of an extractor removal pot sink. Each cartridge is a maximum of 19-1/2" long. Ventilator can also be quipped with an optional fusible link or thermostatically activated fire damper assembly.

Make-Up Air (Perimeter Down Discharge)

Ventilator shall have air registers along perimeter for down discharge of tempered make-up. Supply volume is 80% or designed to the desired air balance.

Application

Island style cooking applications for use over all types of cooking equipment where integral make-up air is required.

Light Fixtures

All light fixtures shall be pre-wired to a single connection point. Ventilators built in multiple sections to be furnished with junction boxes for ease of field connection by the electrical trades. Light bulbs furnished and installed by the Kitchen Equipment Contractor.

Exhaust Fans

Exhaust fans are to be provided and installed by others in compliance with local codes. **Fans should be induced draft, squirrel cage design, equipped with backward inclined blades.**

Fire Protection

NFPA 96 and local codes require a fire extinguishing system for protection of the duct collar and plenum of all ventilators, as well as for the protection of various cooking appliances such as deep fat fryers, griddles, ranges, and broilers, which may be a source of ignition of grease. Consult factory and local fire officials for exact requirements. UL Listed fire protection systems may be pre-piped by Caddy at the time of manufacture, assuring concealment of piping and detectors.

Approvals

Ventilator shall be UL Listed, listed by NSF and be in accordance with all of the recommendations set forth by NFPA 96. All ventilators must meet all applicable codes.



MODEL:

SHC-C-I-ASII---

ADD THE OVERALL LENGTH (IN INCHES) OF THE VENTILATOR AFTER MODEL DESIGNATION

DAMPER TYPE
ND - NO DAMPER
FL - FUSIBLE LINK
T - THERMOSTAT

ADD THE OVERALL WIDTH (IN INCHES) OF THE VENTILATOR AFTER MODEL DESIGNATION

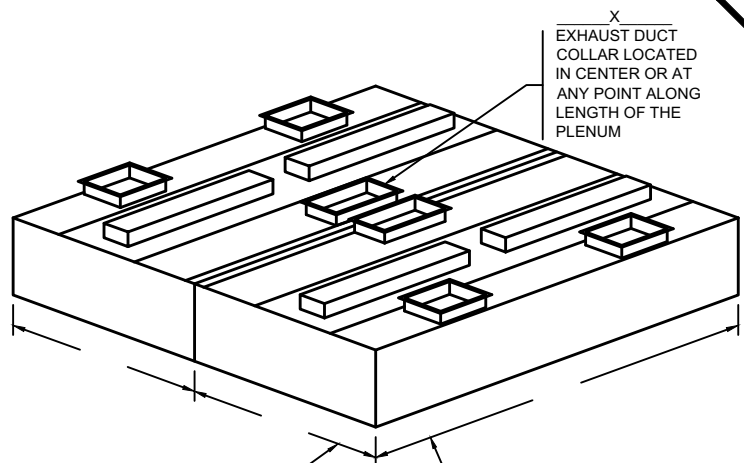

X
EXHAUST DUCT COLLAR LOCATED IN CENTER OR AT ANY POINT ALONG LENGTH OF THE PLENUM

DIMENSION VARIES WITH DEPTH OF THE EQUIPMENT AND REQUIRED OVERHANG

14'-0" MAX. UNIT LENGTH. FOR GREATER LENGTH, JOIN TWO OR MORE UNITS TOGETHER. ALLOW 6" MIN. OVERHANG AT EACH END. IF CHARBROILER IS AT END, OVERHANG 12"

STANDARD LIGHT FIXTURES
 100 WATT INCANDESCENT
 RECESSED INCANDESCENT
 RECESSED FLUORESCENT
 (IF RECESSED FLUORESCENT SPECIFY SIZE)

CONSULT FACTORY FOR NON-STANDARD HEIGHTS
 22" MIN. FRONT OVERHANG
 6" MIN. SIDE OVERHANG (12" MIN. SIDE OVERHANG FOR CHARBROILER)

ITEM # _____
 EST. WEIGHT _____
 LENGTH _____
 WIDTH _____
 HEIGHT _____
 EXHAUST-CFM _____
 DUCT SIZE _____
 S.P. _____

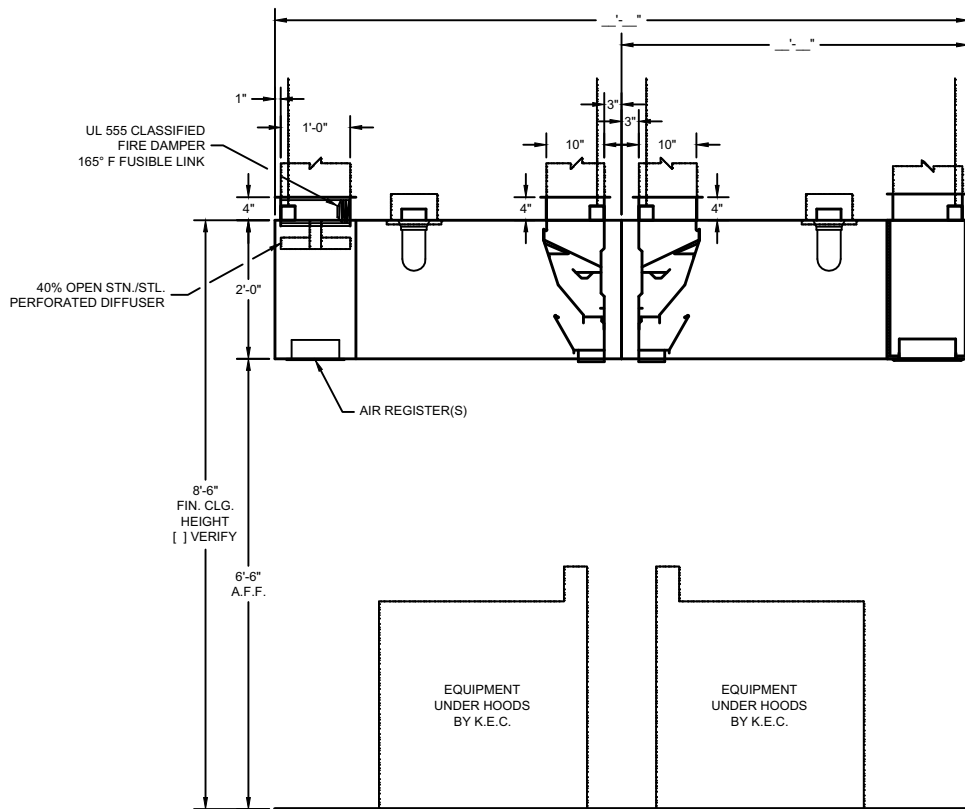

SECTION

DRAWINGS NOT TO SCALE

ENGINEERING DATA

Ventilator Length

Maximum ventilator length in a single section is 14'-0". For lengths greater than 14'-0", join two or more sections. Verify access conditions into building and kitchen space prior to length selection.

Ventilator Hanging Weight

Wt./lineal ft.	Lbs.	90

NOTE: Refer to CADDY AirSystems

Master Engineering Data Sheet in engineering data section for determining light, medium, and heavy duty cooking equipment, C.F.M. requirements (exhaust and supply), duct collar sizes and static pressure requirements.

Electrical Requirements

Light fixtures to be powered by a 120/1/60 circuit.

Mechanical Requirements

The volume of exhaust required is a function of the type of cooking equipment served by the ventilator, and the type and volume of product cooked. Refer to the **CADDY AirSystems**

Master Engineering Data Chart to determine exhaust volume, duct collar sizes, static pressure drop.



Model SHC-C-I

Dry Cartridge Ventilator With Ceiling Supply Plenum

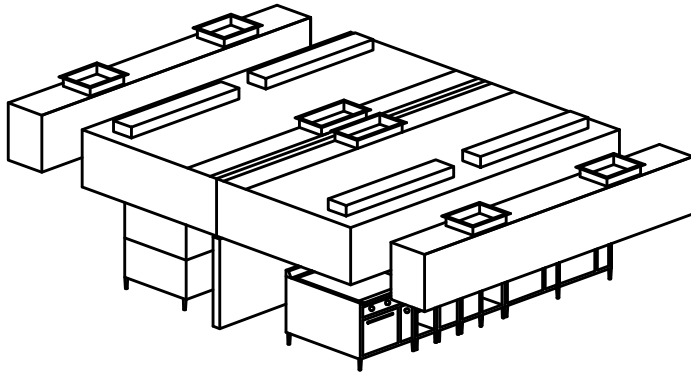

General Specifications

Furnish CADDY *AirSystems* Exhaust Hood Model **SHC-C-W-ASII** as shown on the plans and as described in the following specifications.

General

Exhaust Ventilator shall be constructed of 18 gauge type 300 series stainless steel. All exposed surfaces to have a #4 finish. Construction to meet all requirements of NFPA 96 and NSF Standard No. 2. To include necessary hanger brackets at front and rear suspending from building overhead structure.

Description

The CADDY *AirSystems* Model "SHC" Ventilator is a dry extractor cartridge type and is UL listed under the standards as set forth in UL710 "Exhaust Hoods for Commercial Cooking Equipment." This ventilator is 95% grease extraction efficient when operated and maintained in accordance with design specifications. This high efficiency is accomplished by utilizing removable stainless steel extractor cartridges containing a series of horizontal, self-draining baffles. As the air is drawn around the baffles, the grease, dust and lint particles are slung from the air stream by centrifugal force. As the liquefied grease is extracted, it is drawn off via a trough into grease collection containers at each end of the ventilator. At the end of the cooking day or at scheduled intervals, the cartridges are removed for cleaning without having to climb up or onto the cooking equipment with the use of an extractor removal pot sink. Each cartridge is a maximum of 19-1/2" long. Ventilator can also be quipped with an optional fusible link or thermostatically activated fire damper assembly.

Make-Up Air (Perimeter Down Discharge)

Ventilator shall have air registers along perimeter for down discharge of tempered make-up. Supply volume is 80% or designed to the desired air balance.

Application

Wall mounted canopy style for use over all types of cooking equipment where integral make-up air is required.

Light Fixtures

All light fixtures shall be pre-wired to a single connection point. Ventilators built in multiple sections to be furnished with junction boxes for ease of field connection by the electrical trades. Light bulbs furnished and installed by the Kitchen Equipment Contractor.

Exhaust Fans

Exhaust fans are to be provided and installed by others in compliance with local codes. **Fans should be induced draft, squirrel cage design, equipped with backward inclined blades.**

Fire Protection

NFPA 96 and local codes require a fire extinguishing system for protection of the duct collar and plenum of all ventilators, as well as for the protection of various cooking appliances such as deep fat fryers, griddles, ranges, and broilers, which may be a source of ignition of grease. Consult factory and local fire officials for exact requirements. UL Listed fire protection systems may be pre-piped by Caddy at the time of manufacture, assuring concealment of piping and detectors.

Approvals

Ventilator shall be UL Listed, listed by NSF and be in accordance with all of the recommendations set forth by NFPA 96. All ventilators must meet all applicable codes.



MODEL:

SHC-C-I---

ADD THE OVERALL LENGTH (IN INCHES) OF THE VENTILATOR AFTER MODEL DESIGNATION

DAMPER TYPE
ND - NO DAMPER
FL - FUSIBLE LINK
T - THERMOSTAT

ADD THE OVERALL WIDTH (IN INCHES) OF THE VENTILATOR AFTER MODEL DESIGNATION

X
EXHAUST DUCT COLLAR LOCATED IN CENTER OR AT ANY POINT ALONG LENGTH OF THE PLENUM

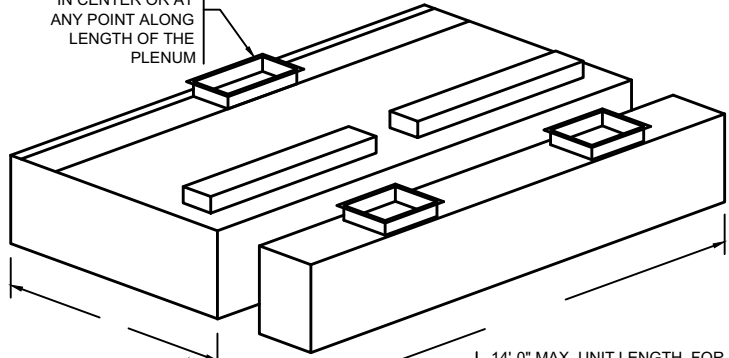

14'-0" MAX. UNIT LENGTH. FOR GREATER LENGTH, JOIN TWO OR MORE UNITS TOGETHER. ALLOW 6" MIN. OVERHANG AT EACH END. IF CHARBROILER IS AT END, OVERHANG 12"

DIMENSION VARIES WITH DEPTH OF THE EQUIPMENT AND REQUIRED OVERHANG

STANDARD LIGHT FIXTURES
 100 WATT INCANDESCENT
 RECESSED INCANDESCENT
 RECESSED FLUORESCENT
(IF RECESSED FLUORESCENT SPECIFY SIZE)

CONSULT FACTORY FOR NON-STANDARD HEIGHTS
22" MIN. FRONT OVERHANG
6" MIN. SIDE OVERHANG
(12" MIN. SIDE OVERHANG FOR CHARBROILER)

ITEM # _____
EST. WEIGHT _____
LENGTH _____
WIDTH _____
HEIGHT _____
EXHAUST-CFM _____
DUCT SIZE _____
S.P. _____

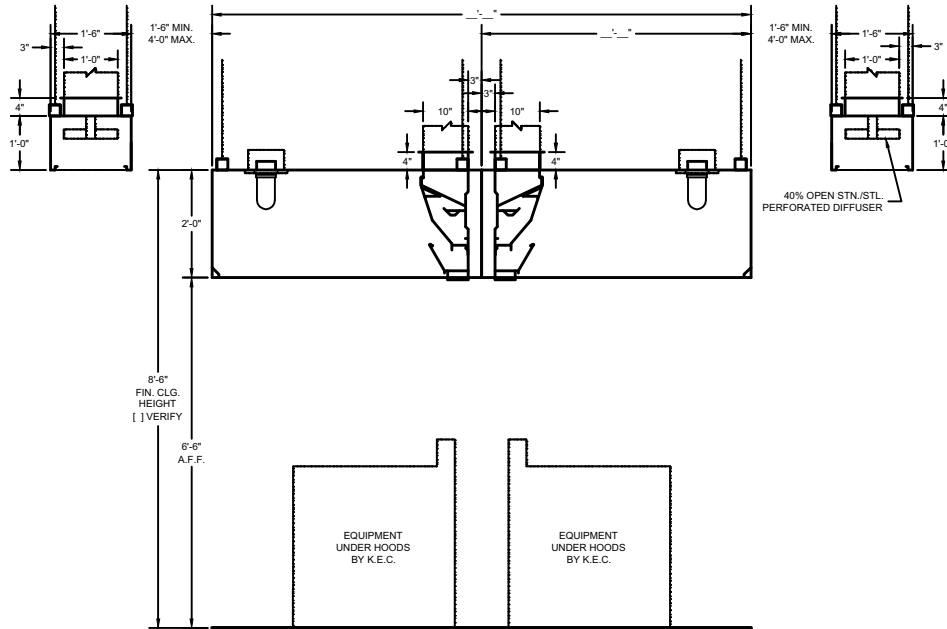

SECTION

DRAWINGS NOT TO SCALE

ENGINEERING DATA

Ventilator Length

Maximum ventilator length in a single section is 14'-0". For lengths greater than 14'-0", join two or more sections. Verify access conditions into building and kitchen space prior to length selection.

Ventilator Hanging Weight

Wt./ lineal ft.	Lbs.	90
-----------------	------	----

NOTE: Refer to CADDY AirSystems

Master Engineering Data Sheet in engineering data section for determining light, medium, and heavy duty cooking equipment, C.F.M. requirements (exhaust and supply), duct collar sizes and static pressure requirements.

Electrical Requirements

Light fixtures to be powered by a 120/1/60 circuit.

Mechanical Requirements

The volume of exhaust required is a function of the type of cooking equipment served by the ventilator, and the type and volume of product cooked. Refer to the **CADDY AirSystems**

Master Engineering Data Chart to determine exhaust volume, duct collar sizes, static pressure drop.





CADDY CORPORATION

Food Service Equipment

Air Systems

Commercial Kitchen Exhaust Systems

Model SHC

Double Island Style

Model SHC-C-II

Dry Cartridge Ventilator

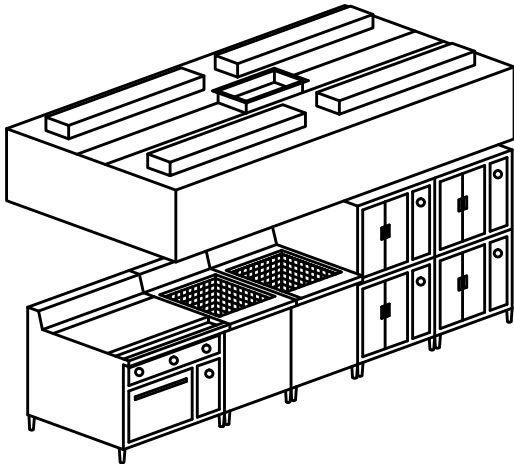

General Specifications

Furnish CADDY *AirSystems* Exhaust Hood Model **SHC-C-II** as shown on the plans and as described in the following specifications.

General

Exhaust Ventilator shall be constructed of 18 gauge type 300 series stainless steel. All exposed surfaces to have a #4 finish. Construction to meet all requirements of NFPA 96 and NSF Standard No. 2. To include necessary hanger brackets at front and rear suspending from building overhead structure.

Description

The CADDY *AirSystems* Model "SHC" Ventilator is a dry extractor cartridge type and is UL listed under the standards as set forth in UL710 "Exhaust Hoods for Commercial Cooking Equipment." This ventilator is 95% grease extraction efficient when operated and maintained in accordance with design specifications. This high efficiency is accomplished by utilizing removable stainless steel extractor cartridges containing a series of horizontal, self-draining baffles. As the air is drawn around the baffles, the grease, dust and lint particles are slung from the air stream by centrifugal force. As the liquefied grease is extracted, it is drawn off via a trough into grease collection containers at each end of the ventilator. At the end of the cooking day or at scheduled intervals, the cartridges are removed for cleaning without having to climb up or onto the cooking equipment with the use of an extractor removal pot sink. Each cartridge is a maximum of 19-1/2" long. Ventilator can also be quipped with an optional fusible link or thermostatically activated fire damper assembly.

Application

Island mounted exhaust-only canopy style for use over all types of cooking equipment.

Light Fixtures

All light fixtures shall be pre-wired to a single connection point. Ventilators built in multiple sections to be furnished with junction boxes for ease of field connection by the electrical trades. Light bulbs furnished and installed by the Kitchen Equipment Contractor.

Exhaust Fans

Exhaust fans are to be provided and installed by others in compliance with local codes. **Fans should be induced draft, squirrel cage design, equipped with backward inclined blades.**

Fire Protection

NFPA 96 and local codes require a fire extinguishing system for protection of the duct collar and plenum of all ventilators, as well as for the protection of various cooking appliances such as deep fat fryers, griddles, ranges, and broilers, which may be a source of ignition of grease. Consult factory and local fire officials for exact requirements. UL Listed fire protection systems may be pre-piped by Caddy at the time of manufacture, assuring concealment of piping and detectors.

Approvals

Ventilator shall be UL Listed, listed by NSF and be in accordance with all of the recommendations set forth by NFPA 96. All ventilators must meet all applicable codes.



MODEL:

SHC-C-II---

ADD THE OVERALL LENGTH (IN INCHES) OF THE VENTILATOR AFTER MODEL DESIGNATION

DAMPER TYPE
 ND - NO DAMPER
 FL - FUSIBLE LINK
 T - THERMOSTAT

ADD THE OVERALL WIDTH (IN INCHES) OF THE VENTILATOR AFTER MODEL DESIGNATION

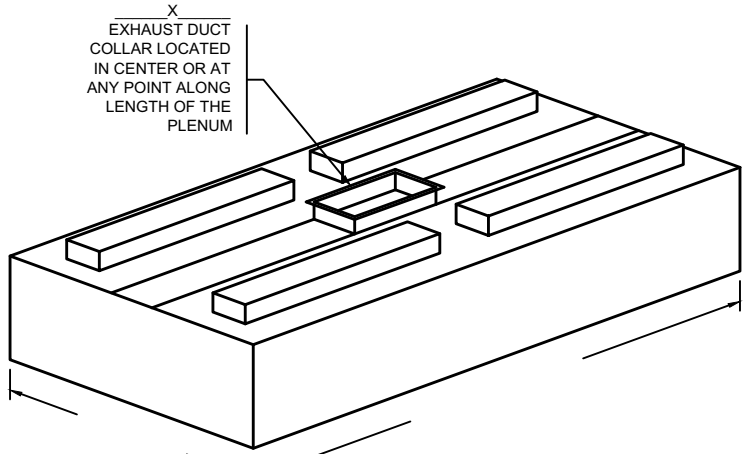

X
 EXHAUST DUCT COLLAR LOCATED IN CENTER OR AT ANY POINT ALONG LENGTH OF THE PLENUM

STANDARD LIGHT FIXTURES
 100 WATT INCANDESCENT
 RECESSED INCANDESCENT
 RECESSED FLUORESCENT
 (IF RECESSED FLUORESCENT SPECIFY SIZE)

CONSULT FACTORY FOR NON-STANDARD HEIGHTS
 12" MIN. FRONT OVERHANG
 6" MIN. SIDE OVERHANG
 (12" MIN. SIDE OVERHANG FOR CHARBROILER)

ITEM # _____
 EST. WEIGHT _____
 LENGTH _____
 WIDTH _____
 HEIGHT _____
 EXHAUST-CFM _____
 DUCT SIZE _____
 S.P. _____

DIMENSION VARIES WITH DEPTH OF THE EQUIPMENT AND REQUIRED OVERHANG

14'-0" MAX. UNIT LENGTH. FOR GREATER LENGTH, JOIN TWO OR MORE UNITS TOGETHER. ALLOW 6" MIN. OVERHANG AT EACH END. IF CHARBROILER IS AT END, OVERHANG 12"

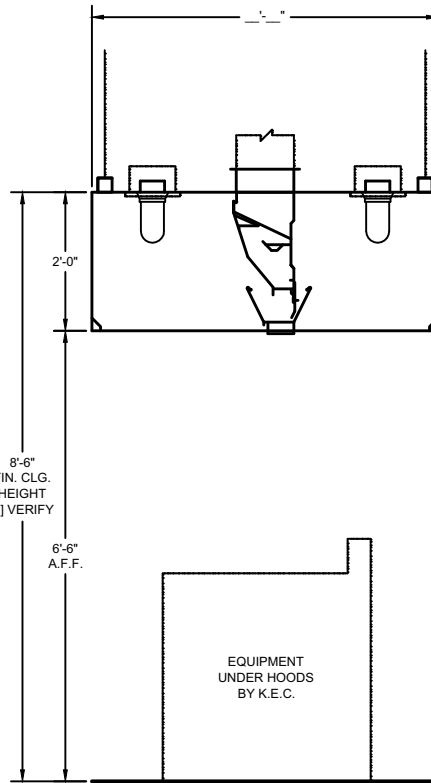

SECTION

DRAWINGS NOT TO SCALE

ENGINEERING DATA

Ventilator Length

Maximum ventilator length in a single section is 14'-0". For lengths greater than 14'-0", join two or more sections. Verify access conditions into building and kitchen space prior to length selection.

Ventilator Hanging Weight

Wt./ lineal ft.	Lbs.	75
-----------------	------	----

NOTE: Refer to **CADDY AirSystems**

Master Engineering Data Sheet in engineering data section for determining light, medium, and heavy duty cooking equipment, C.F.M. requirements (exhaust and supply), duct collar sizes and static pressure requirements.

Electrical Requirements

Light fixtures to be powered by a 120/1/60 circuit.

Mechanical Requirements

The volume of exhaust required is a function of the type of cooking equipment served by the ventilator, and the type and volume of product cooked. Refer to the **CADDY AirSystems**

Master Engineering Data Chart to determine exhaust volume, duct collar sizes, static pressure drop.



Model SHC-C-II-PA Dry Cartridge Ventilator

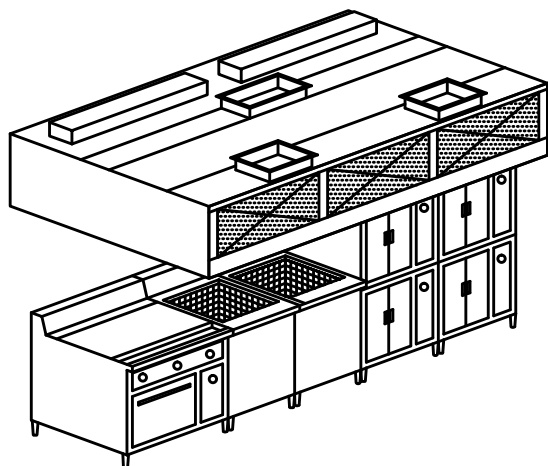

General Specifications

Furnish CADDY *AirSystems* Exhaust Hood Model **SHC-C-II-PA** as shown on the plans and as described in the following specifications.

General

Exhaust Ventilator shall be constructed of 18 gauge type 300 series stainless steel. All exposed surfaces to have a #4 finish. Construction to meet all requirements of NFPA 96 and NSF Standard No. 2. To include necessary hanger brackets at front and rear suspending from building overhead structure.

Description

The CADDY *AirSystems* Model "SHC" Ventilator is a dry extractor cartridge type and is UL listed under the standards as set forth in UL710 "Exhaust Hoods for Commercial Cooking Equipment." This ventilator is 95% grease extraction efficient when operated and maintained in accordance with design specifications. This high efficiency is accomplished by utilizing removable stainless steel extractor cartridges containing a series of horizontal, self-draining baffles. As the air is drawn around the baffles, the grease, dust and lint particles are slung from the air stream by centrifugal force. As the liquefied grease is extracted, it is drawn off via a trough into grease collection containers at each end of the ventilator. At the end of the cooking day or at scheduled intervals, the cartridges are removed for cleaning without having to climb up or onto the cooking equipment with the use of an extractor removal pot sink. Each cartridge is a maximum of 19-1/2" long. Ventilator can also be equipped with an optional fusible link or thermostatically activated fire damper assembly.

Make-Up Air (Front Face Discharge)

Ventilator shall have 40% open stainless steel perforated screens along front face for discharge of tempered make-up air. Supply volume is 80% or designed to the desired air balance.

Application

Island style cooking applications for use over all types of cooking equipment where integral make-up air is required.

Light Fixtures

All light fixtures shall be pre-wired to a single connection point. Ventilators built in multiple sections to be furnished with junction boxes for ease of field connection by the electrical trades. Light bulbs furnished and installed by the Kitchen Equipment Contractor.

Exhaust Fans

Exhaust fans are to be provided and installed by others in compliance with local codes. **Fans should be induced draft, squirrel cage design, equipped with backward inclined blades.**

Fire Protection

NFPA 96 and local codes require a fire extinguishing system for protection of the duct collar and plenum of all ventilators, as well as for the protection of various cooking appliances such as deep fat fryers, griddles, ranges, and broilers, which may be a source of ignition of grease. Consult factory and local fire officials for exact requirements. UL Listed fire protection systems may be pre-piped by Caddy at the time of manufacture, assuring concealment of piping and detectors.

Approvals

Ventilator shall be UL Listed, listed by NSF and be in accordance with all of the recommendations set forth by NFPA 96. All ventilators must meet all applicable codes.



MODEL:

SHC-C-II-PA---

ADD THE OVERALL LENGTH (IN INCHES) OF THE VENTILATOR AFTER MODEL DESIGNATION

DAMPER TYPE
ND - NO DAMPER
FL - FUSIBLE LINK
T - THERMOSTAT

ADD THE OVERALL WIDTH (IN INCHES) OF THE VENTILATOR AFTER MODEL DESIGNATION

X
EXHAUST DUCT COLLAR LOCATED IN CENTER OR AT ANY POINT ALONG LENGTH OF THE PLENUM

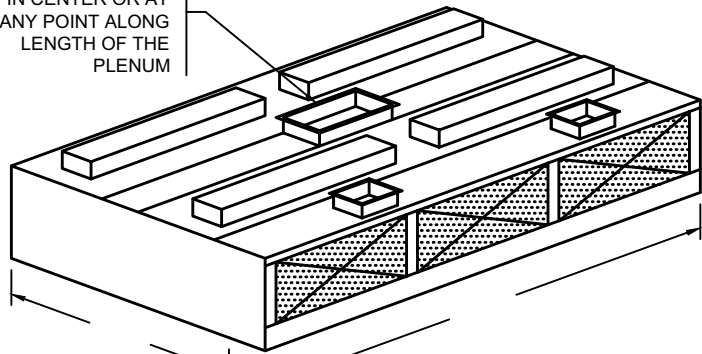

DIMENSION VARIES WITH DEPTH OF THE EQUIPMENT AND REQUIRED OVERHANG

14'-0" MAX. UNIT LENGTH. FOR GREATER LENGTH, JOIN TWO OR MORE UNITS TOGETHER. ALLOW 6" MIN. OVERHANG AT EACH END. IF CHARBROILER IS AT END, OVERHANG 12"

STANDARD LIGHT FIXTURES
 100 WATT INCANDESCENT
 RECESSED INCANDESCENT
 RECESSED FLUORESCENT
 (IF RECESSED FLUORESCENT SPECIFY SIZE)

CONSULT FACTORY FOR NON-STANDARD HEIGHTS
 12" MIN. FRONT OVERHANG
 6" MIN. SIDE OVERHANG
 (12" MIN. SIDE OVERHANG FOR CHARBROILER)

ITEM # _____
 EST. WEIGHT _____
 LENGTH _____
 WIDTH _____
 HEIGHT _____
 EXHAUST-CFM _____
 DUCT SIZE _____
 S.P. _____

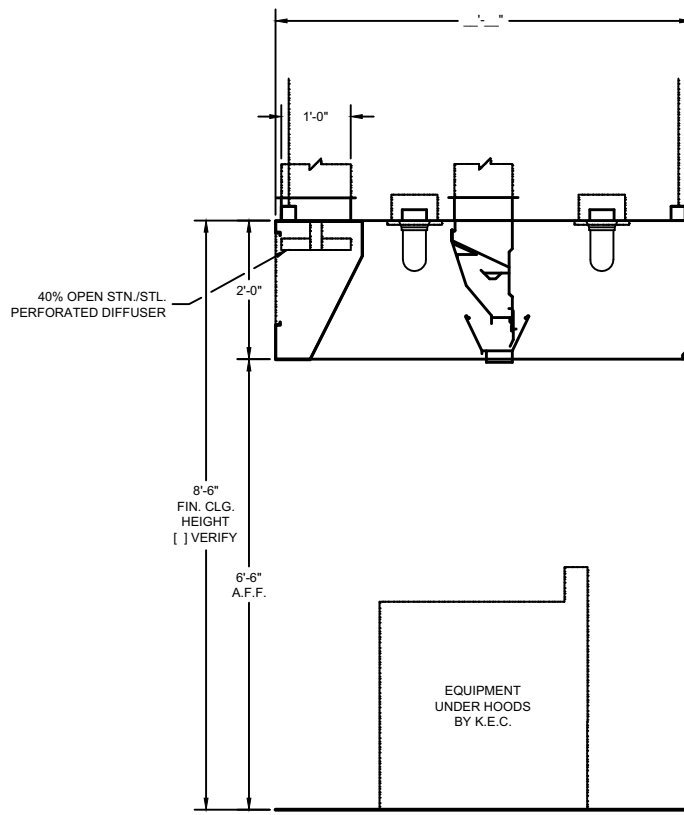

SECTION

DRAWINGS NOT TO SCALE

ENGINEERING DATA

Ventilator Length

Maximum ventilator length in a single section is 14'-0". For lengths greater than 14'-0", join two or more sections. Verify access conditions into building and kitchen space prior to length selection.

Ventilator Hanging Weight

Wt./ lineal ft.	Lbs.	90
-----------------	------	----

NOTE: Refer to **CADDY AirSystems**

Master Engineering Data Sheet in engineering data section for determining light, medium, and heavy duty cooking equipment, C.F.M. requirements (exhaust and supply), duct collar sizes and static pressure requirements.

Electrical Requirements

Light fixtures to be powered by a 120/1/60 circuit.

Mechanical Requirements

The volume of exhaust required is a function of the type of cooking equipment served by the ventilator, and the type and volume of product cooked. Refer to the **CADDY AirSystems**

Master Engineering Data Chart to determine exhaust volume, duct collar sizes, static pressure drop.



Model SHC-C-II-ASI Dry Cartridge Ventilator

ITEM NO:

PROJECT:

LOCATION:

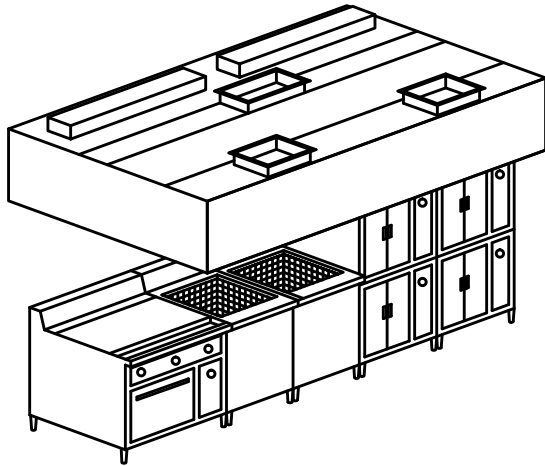

General Specifications

Furnish CADDY *AirSystems* Exhaust Hood Model **SHC-C-II-ASI** as shown on the plans and as described in the following specifications.

General

Exhaust Ventilator shall be constructed of 18 gauge type 300 series stainless steel. All exposed surfaces to have a #4 finish. Construction to meet all requirements of NFPA 96 and NSF Standard No. 2. To include necessary hanger brackets at front and rear suspending from building overhead structure.

Description

The CADDY *AirSystems* Model "SHC" Ventilator is a dry extractor cartridge type and is UL listed under the standards as set forth in UL710 "Exhaust Hoods for Commercial Cooking Equipment." This ventilator is 95% grease extraction efficient when operated and maintained in accordance with design specifications. This high efficiency is accomplished by utilizing removable stainless steel extractor cartridges containing a series of horizontal, self-draining baffles. As the air is drawn around the baffles, the grease, dust and lint particles are slung from the air stream by centrifugal force. As the liquefied grease is extracted, it is drawined off via a trough into grease collection containers at each end of the ventilator. At the end of the cooking day or at scheduled intervals, the cartridges are removed for cleaning without having to climb up or onto the cooking equipment with the use of an extractor removal pot sink. Each cartridge is a maximum of 19-1/2" long. Ventilator can also be quipped with an optional fusible link or thermostatically activated fire damper assembly.

Make-Up Air (Internal Discharge)

Ventilator shall have a fully insulated supply plenum with duct collar/fire damper assemblies and air registers internally mounted for discharging untempered make-up air directly into canopy of ventilator. The amount of make-up air supplied through this design is directly related to the type of cooking equipment located beneath the hood. The percentage of supply air distributed will vary as a function of the thermal currents generated by each individual appliance. When specifying this style, consult factory for specific supply volumes. This air may be untempered in most areas, depending upon climatic conditions and the type of cooking equipment.

Application

Island style cooking applications for use over all types of cooking equipment where integral make-up air is required.

Light Fixtures

All light fixtures shall be pre-wired to a single connection point. Ventilators built in multiple sections to be furnished with junction boxes for ease of field connection by the electrical trades. Light bulbs furnished and installed by the Kitchen Equipment Contractor.

Exhaust Fans

Exhaust fans are to be provided and installed by others in compliance with local codes. **Fans should be induced draft, squirrel cage design, equipped with backward inclined blades.**

Fire Protection

NFPA 96 and local codes require a fire extinguishing system for protection of the duct collar and plenum of all ventilators, as well as for the protection of various cooking appliances such as deep fat fryers, griddles, ranges, and broilers, which may be a source of ignition of grease. Consult factory and local fire officials for exact requirements. UL Listed fire protection systems may be pre-piped by Caddy at the time of manufacture, assuring concealment of piping and detectors.

Approvals

Ventilator shall be UL Listed, listed by NSF and be in accordance with all of the recommendations set forth by NFPA 96. All ventilators must meet all applicable codes.



MODEL:

SHC-C-II-ASI---

ADD THE OVERALL LENGTH (IN INCHES) OF THE VENTILATOR AFTER MODEL DESIGNATION

DAMPER TYPE
ND - NO DAMPER
FL - FUSIBLE LINK
T - THERMOSTAT

ADD THE OVERALL WIDTH (IN INCHES) OF THE VENTILATOR AFTER MODEL DESIGNATION

X
EXHAUST DUCT COLLAR LOCATED IN CENTER OR AT ANY POINT ALONG LENGTH OF THE PLENUM

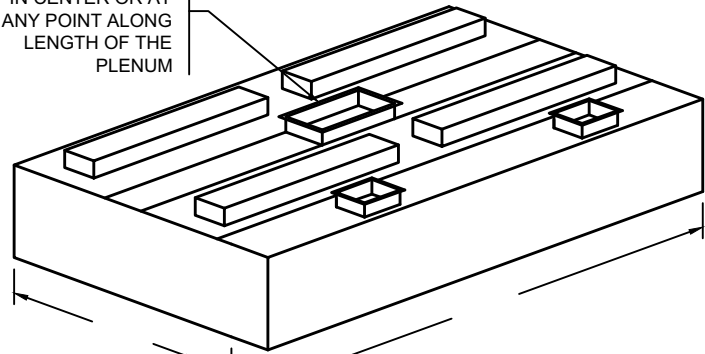

DIMENSION VARIES WITH DEPTH OF THE EQUIPMENT AND REQUIRED OVERHANG

14'-0" MAX. UNIT LENGTH. FOR GREATER LENGTH, JOIN TWO OR MORE UNITS TOGETHER. ALLOW 6" MIN. OVERHANG AT EACH END. IF CHARBROILER IS AT END, OVERHANG 12"

STANDARD LIGHT FIXTURES
 100 WATT INCANDESCENT
 RECESSED INCANDESCENT
 RECESSED FLUORESCENT
 (IF RECESSED FLUORESCENT SPECIFY SIZE)

CONSULT FACTORY FOR NON-STANDARD HEIGHTS
 22" MIN. FRONT OVERHANG
 6" MIN. SIDE OVERHANG
 (12" MIN. SIDE OVERHANG FOR CHARBROILER)

ITEM #	_____
EST. WEIGHT	_____
LENGTH	_____
WIDTH	_____
HEIGHT	_____
EXHAUST-CFM	_____
DUCT SIZE	_____
S.P.	_____

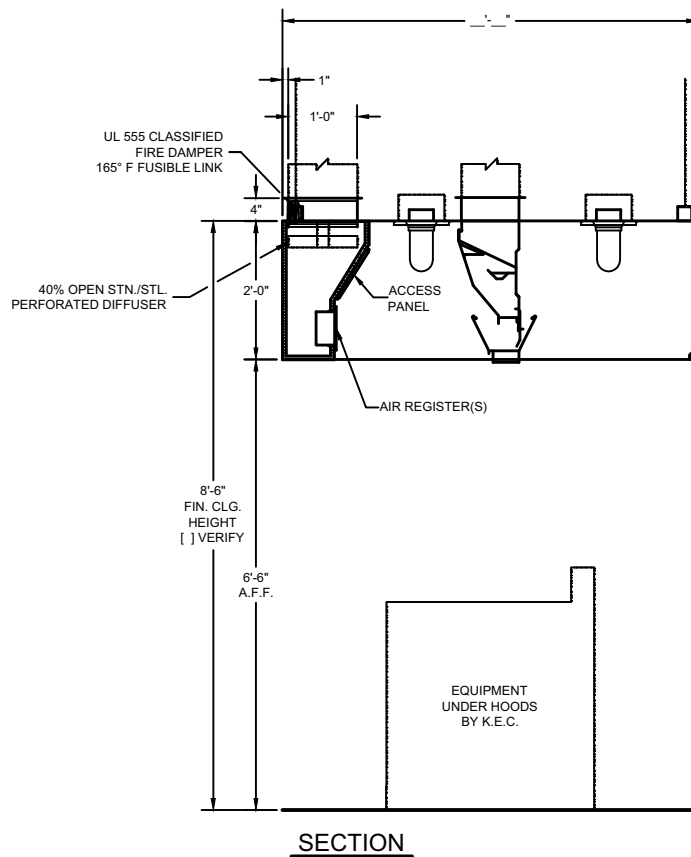

DRAWINGS NOT TO SCALE

ENGINEERING DATA

Ventilator Length

Maximum ventilator length in a single section is 14'-0". For lengths greater than 14'-0", join two or more sections. Verify access conditions into building and kitchen space prior to length selection.

Ventilator Hanging Weight

Wt./ lineal ft.	Lbs.	90
-----------------	------	----

NOTE: Refer to CADDY AirSystems

Master Engineering Data Sheet in engineering data section for determining light, medium, and heavy duty cooking equipment, C.F.M. requirements (exhaust and supply), duct collar sizes and static pressure requirements.

Electrical Requirements

Light fixtures to be powered by a 120/1/60 circuit.

Mechanical Requirements

The volume of exhaust required is a function of the type of cooking equipment served by the ventilator, and the type and volume of product cooked. Refer to the **CADDY AirSystems**

Master Engineering Data Chart to determine exhaust volume, duct collar sizes, static pressure drop.



Model SHC-C-II-AA Dry Cartridge Ventilator

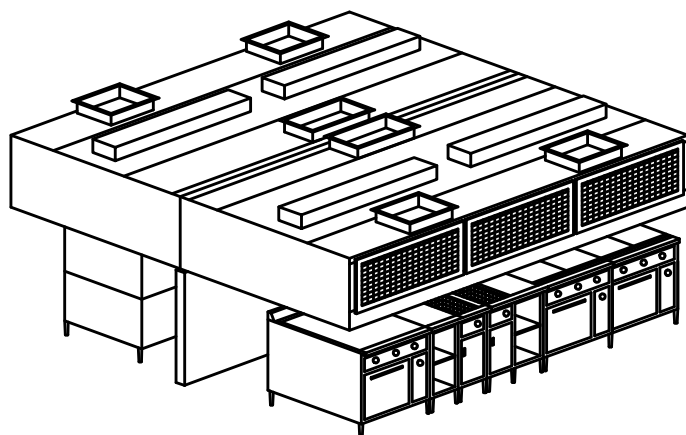

General Specifications

Furnish CADDY *AirSystems* Exhaust Hood Model **SHC-C-II-AA** as shown on the plans and as described in the following specifications.

General

Exhaust Ventilator shall be constructed of 18 gauge type 300 series stainless steel. All exposed surfaces to have a #4 finish. Construction to meet all requirements of NFPA 96 and NSF Standard No. 2. To include necessary hanger brackets at front and rear suspending from building overhead structure.

Description

The CADDY *AirSystems* Model "SHC" Ventilator is a dry extractor cartridge type and is UL listed under the standards as set forth in UL710 "Exhaust Hoods for Commercial Cooking Equipment." This ventilator is 95% grease extraction efficient when operated and maintained in accordance with design specifications. This high efficiency is accomplished by utilizing removable stainless steel extractor cartridges containing a series of horizontal, self-draining baffles. As the air is drawn around the baffles, the grease, dust and lint particles are slung from the air stream by centrifugal force. As the liquefied grease is extracted, it is drawn off via a trough into grease collection containers at each end of the ventilator. At the end of the cooking day or at scheduled intervals, the cartridges are removed for cleaning without having to climb up or onto the cooking equipment with the use of an extractor removal pot sink. Each cartridge is a maximum of 19-1/2" long. Ventilator can also be quipped with an optional fusible link or thermostatically activated fire damper assembly.

Make-Up Air (Front Face Register Discharge)

Ventilator shall have air registers along front face for discharge of tempered make-up air. Supply volume is 80%, or designed to the desired air balance.

Application

Island style cooking applications for use over all types of cooking equipment where integral make-up air is required.

Light Fixtures

All light fixtures shall be pre-wired to a single connection point. Ventilators built in multiple sections to be furnished with junction boxes for ease of field connection by the electrical trades. Light bulbs furnished and installed by the Kitchen Equipment Contractor.

Exhaust Fans

Exhaust fans are to be provided and installed by others in compliance with local codes. **Fans should be induced draft, squirrel cage design, equipped with backward inclined blades.**

Fire Protection

NFPA 96 and local codes require a fire extinguishing system for protection of the duct collar and plenum of all ventilators, as well as for the protection of various cooking appliances such as deep fat fryers, griddles, ranges, and broilers, which may be a source of ignition of grease. Consult factory and local fire officials for exact requirements. UL Listed fire protection systems may be pre-piped by Caddy at the time of manufacture, assuring concealment of piping and detectors.

Approvals

Ventilator shall be UL Listed, listed by NSF and be in accordance with all of the recommendations set forth by NFPA 96. All ventilators must meet all applicable codes.



MODEL:

SHC-C-II-AA---

ADD THE OVERALL LENGTH (IN INCHES) OF THE VENTILATOR AFTER MODEL DESIGNATION

DAMPER TYPE
ND - NO DAMPER
FL - FUSIBLE LINK
T - THERMOSTAT

ADD THE OVERALL WIDTH (IN INCHES) OF THE VENTILATOR AFTER MODEL DESIGNATION

X
EXHAUST DUCT COLLAR LOCATED IN CENTER OR AT ANY POINT ALONG LENGTH OF THE PLENUM

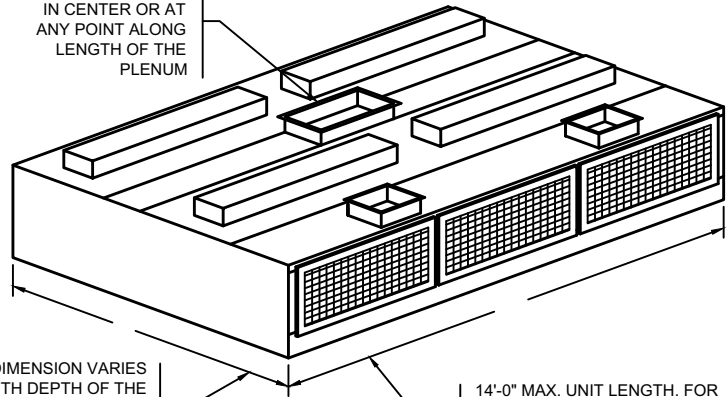

DIMENSION VARIES WITH DEPTH OF THE EQUIPMENT AND REQUIRED OVERHANG

14'-0" MAX. UNIT LENGTH. FOR GREATER LENGTH, JOIN TWO OR MORE UNITS TOGETHER. ALLOW 6" MIN. OVERHANG AT EACH END. IF CHARBROILER IS AT END, OVERHANG 12"

STANDARD LIGHT FIXTURES
 100 WATT INCANDESCENT
 RECESSED INCANDESCENT
 RECESSED FLUORESCENT
 (IF RECESSED FLUORESCENT SPECIFY SIZE)

CONSULT FACTORY FOR NON-STANDARD HEIGHTS
 12" MIN. FRONT OVERHANG
 6" MIN. SIDE OVERHANG
 (12" MIN. SIDE OVERHANG FOR CHARBROILER)

ITEM #	_____
EST. WEIGHT	_____
LENGTH	_____
WIDTH	_____
HEIGHT	_____
EXHAUST-CFM	_____
DUCT SIZE	_____
S.P.	_____

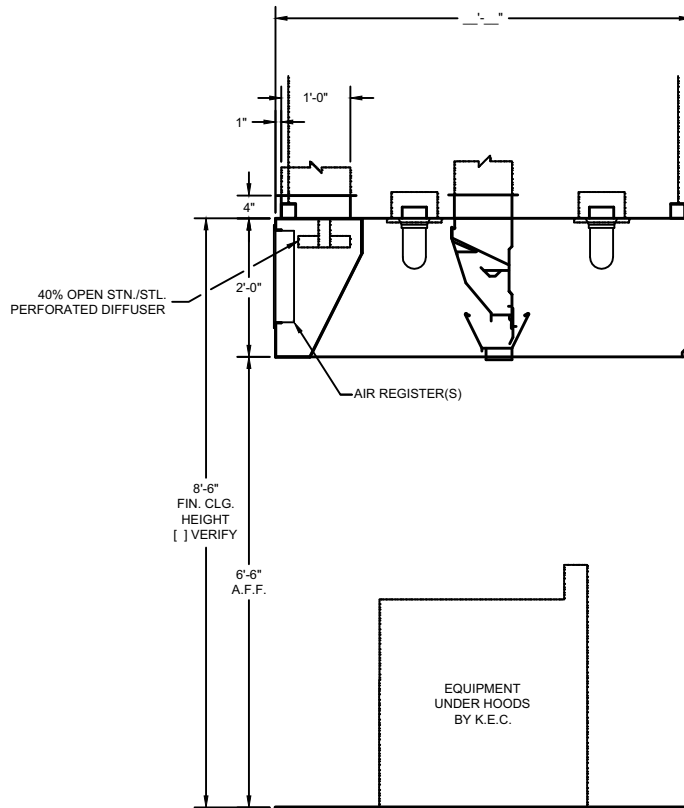

DRAWINGS NOT TO SCALE

SECTION

ENGINEERING DATA

Ventilator Length

Maximum ventilator length in a single section is 14'-0". For lengths greater than 14'-0", join two or more sections. Verify access conditions into building and kitchen space prior to length selection.

Ventilator Hanging Weight

Wt./ lineal ft.	Lbs.	90
-----------------	------	----

NOTE: Refer to CADDY AirSystems

Master Engineering Data Sheet in engineering data section for determining light, medium, and heavy duty cooking equipment, C.F.M. requirements (exhaust and supply), duct collar sizes and static pressure requirements.

Electrical Requirements

Light fixtures to be powered by a 120/1/60 circuit.

Mechanical Requirements

The volume of exhaust required is a function of the type of cooking equipment served by the ventilator, and the type and volume of product cooked. Refer to the **CADDY AirSystems**

Master Engineering Data Chart to determine exhaust volume, duct collar sizes, static pressure drop.



Model SHC-C-II-ASII Dry Cartridge Ventilator

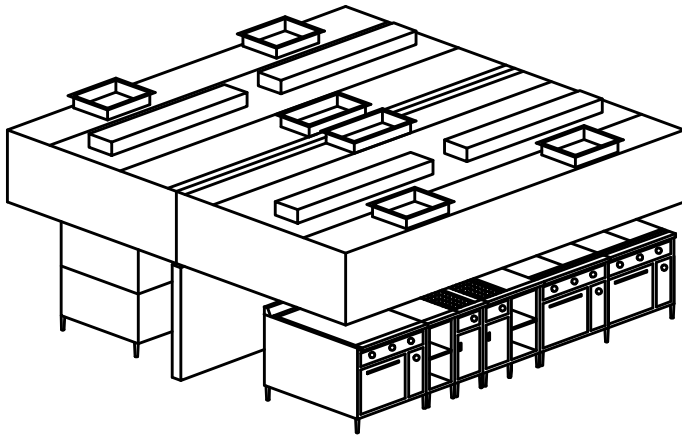

General Specifications

Furnish CADDY *AirSystems* Exhaust Hood Model **SHC-C-II-ASII** as shown on the plans and as described in the following specifications.

General

Exhaust Ventilator shall be constructed of 18 gauge type 300 series stainless steel. All exposed surfaces to have a #4 finish. Construction to meet all requirements of NFPA 96 and NSF Standard No. 2. To include necessary hanger brackets at front and rear suspending from building overhead structure.

Description

The CADDY *AirSystems* Model "SHC" Ventilator is a dry extractor cartridge type and is UL listed under the standards as set forth in UL710 "Exhaust Hoods for Commercial Cooking Equipment." This ventilator is 95% grease extraction efficient when operated and maintained in accordance with design specifications. This high efficiency is accomplished by utilizing removable stainless steel extractor cartridges containing a series of horizontal, self-draining baffles. As the air is drawn around the baffles, the grease, dust and lint particles are slung from the air stream by centrifugal force. As the liquefied grease is extracted, it is drawn off via a trough into grease collection containers at each end of the ventilator. At the end of the cooking day or at scheduled intervals, the cartridges are removed for cleaning without having to climb up or onto the cooking equipment with the use of an extractor removal pot sink. Each cartridge is a maximum of 19-1/2" long. Ventilator can also be quipped with an optional fusible link or thermostatically activated fire damper assembly.

Make-Up Air (Perimeter Down Discharge)

Ventilator shall have air registers along perimeter for down discharge of tempered make-up. Supply volume is 80% or designed to the desired air balance.

Application

Island style cooking applications for use over all types of cooking equipment where integral make-up air is required.

Light Fixtures

All light fixtures shall be pre-wired to a single connection point. Ventilators built in multiple sections to be furnished with junction boxes for ease of field connection by the electrical trades. Light bulbs furnished and installed by the Kitchen Equipment Contractor.

Exhaust Fans

Exhaust fans are to be provided and installed by others in compliance with local codes. **Fans should be induced draft, squirrel cage design, equipped with backward inclined blades.**

Fire Protection

NFPA 96 and local codes require a fire extinguishing system for protection of the duct collar and plenum of all ventilators, as well as for the protection of various cooking appliances such as deep fat fryers, griddles, ranges, and broilers, which may be a source of ignition of grease. Consult factory and local fire officials for exact requirements. UL Listed fire protection systems may be pre-piped by Caddy at the time of manufacture, assuring concealment of piping and detectors.

Approvals

Ventilator shall be UL Listed, listed by NSF and be in accordance with all of the recommendations set forth by NFPA 96. All ventilators must meet all applicable codes.



MODEL:

SHC-C-II-ASII---

ADD THE OVERALL LENGTH (IN INCHES) OF THE VENTILATOR AFTER MODEL DESIGNATION

DAMPER TYPE
ND - NO DAMPER
FL - FUSIBLE LINK
T - THERMOSTAT

ADD THE OVERALL WIDTH (IN INCHES) OF THE VENTILATOR AFTER MODEL DESIGNATION

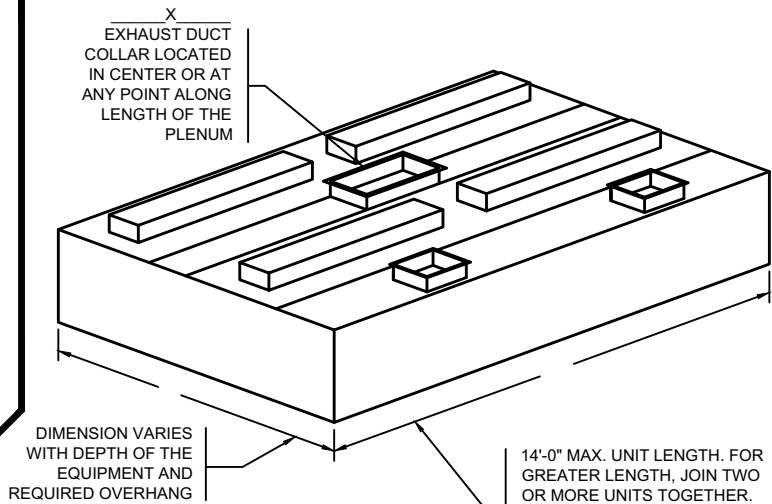

14'-0" MAX. UNIT LENGTH. FOR GREATER LENGTH, JOIN TWO OR MORE UNITS TOGETHER. ALLOW 6" MIN. OVERHANG AT EACH END. IF CHARBROILER IS AT END, OVERHANG 12"

STANDARD LIGHT FIXTURES
 100 WATT INCANDESCENT
 RECESSED INCANDESCENT
 RECESSED FLUORESCENT
 (IF RECESSED FLUORESCENT SPECIFY SIZE)

CONSULT FACTORY FOR NON-STANDARD HEIGHTS
 22" MIN. FRONT OVERHANG
 6" MIN. SIDE OVERHANG
 (12" MIN. SIDE OVERHANG FOR CHARBROILER)

ITEM #	_____
EST. WEIGHT	_____
LENGTH	_____
WIDTH	_____
HEIGHT	_____
EXHAUST-CFM	_____
DUCT SIZE	_____
S.P.	_____

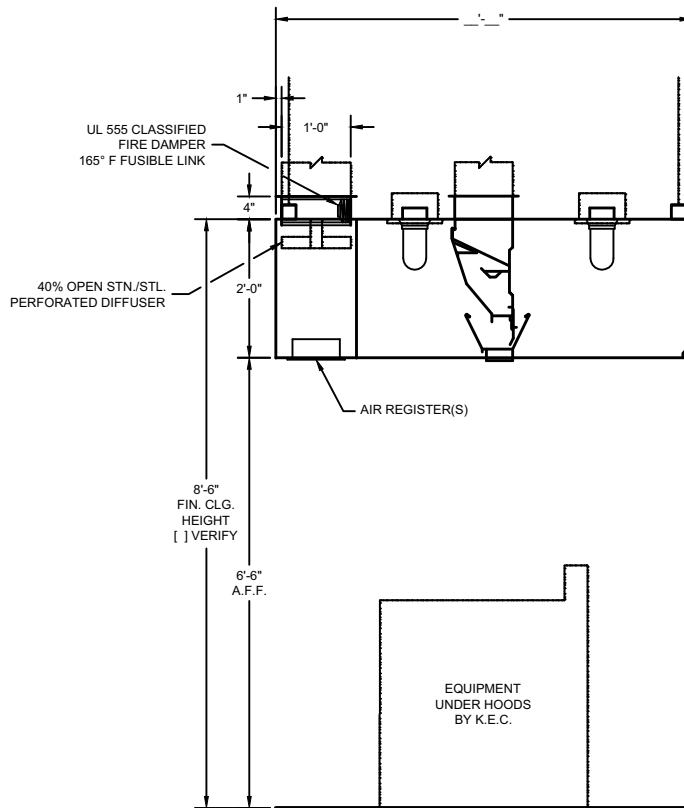

SECTION

DRAWINGS NOT TO SCALE

ENGINEERING DATA

Ventilator Length

Maximum ventilator length in a single section is 14'-0". For lengths greater than 14'-0", join two or more sections. Verify access conditions into building and kitchen space prior to length selection.

Ventilator Hanging Weight

Wt./ lineal ft.	Lbs.	90
-----------------	------	----

NOTE: Refer to CADDY AirSystems

Master Engineering Data Sheet in engineering data section for determining light, medium, and heavy duty cooking equipment, C.F.M. requirements (exhaust and supply), duct collar sizes and static pressure requirements.

Electrical Requirements

Light fixtures to be powered by a 120/1/60 circuit.

Mechanical Requirements

The volume of exhaust required is a function of the type of cooking equipment served by the ventilator, and the type and volume of product cooked. Refer to the **CADDY AirSystems**

Master Engineering Data Chart to determine exhaust volume, duct collar sizes, static pressure drop.



Model SHC-C-II

Dry Cartridge Ventilator With Ceiling Supply Plenum

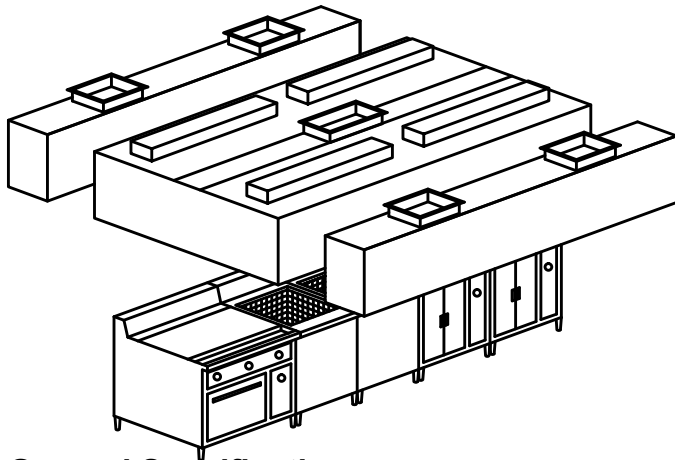

General Specifications

Furnish CADDY *AirSystems* Exhaust Hood Model **SHC-C-II-ASII** as shown on the plans and as described in the following specifications.

General

Exhaust Ventilator shall be constructed of 18 gauge type 300 series stainless steel. All exposed surfaces to have a #4 finish. Construction to meet all requirements of NFPA 96 and NSF Standard No. 2. To include necessary hanger brackets at front and rear suspending from building overhead structure.

Description

The CADDY *AirSystems* Model "SHC" Ventilator is a dry extractor cartridge type and is UL listed under the standards as set forth in UL710 "Exhaust Hoods for Commercial Cooking Equipment." This ventilator is 95% grease extraction efficient when operated and maintained in accordance with design specifications. This high efficiency is accomplished by utilizing removable stainless steel extractor cartridges containing a series of horizontal, self-draining baffles. As the air is drawn around the baffles, the grease, dust and lint particles are slung from the air stream by centrifugal force. As the liquefied grease is extracted, it is drawined off via a trough into grease collection containers at each end of the ventilator. At the end of the cooking day or at scheduled intervals, the cartridges are removed for cleaning without having to climb up or onto the cooking equipment with the use of an extractor removal pot sink. Each cartridge is a maximum of 19-1/2" long. Ventilator can also be quipped with an optional fusible link or thermostatically activated fire damper assembly.

Make-Up Air (Perimeter Down Discharge)

Ventilator shall have air registers along perimeter for down discharge of tempered make-up. Supply volume is 80% or designed to the desired air balance.

Application

Island style cooking applications for use over all types of cooking equipment where integral make-up air is required.

Light Fixtures

All light fixtures shall be pre-wired to a single connection point. Ventilators built in multiple sections to be furnished with junction boxes for ease of field connection by the electrical trades. Light bulbs furnished and installed by the Kitchen Equipment Contractor.

Exhaust Fans

Exhaust fans are to be provided and installed by others in compliance with local codes. **Fans should be induced draft, squirrel cage design, equipped with backward inclined blades.**

Fire Protection

NFPA 96 and local codes require a fire extinguishing system for protection of the duct collar and plenum of all ventilators, as well as for the protection of various cooking appliances such as deep fat fryers, griddles, ranges, and broilers, which may be a source of ignition of grease. Consult factory and local fire officials for exact requirements. UL Listed fire protection systems may be pre-piped by Caddy at the time of manufacture, assuring concealment of piping and detectors.

Approvals

Ventilator shall be UL Listed, listed by NSF and be in accordance with all of the recommendations set forth by NFPA 96. All ventilators must meet all applicable codes.



MODEL:

SHC-C-II- [] - [] - []

ADD THE OVERALL LENGTH (IN INCHES) OF THE VENTILATOR AFTER MODEL DESIGNATION

DAMPER TYPE
ND - NO DAMPER
FL - FUSIBLE LINK
T - THERMOSTAT

ADD THE OVERALL WIDTH (IN INCHES) OF THE VENTILATOR AFTER MODEL DESIGNATION

X
EXHAUST DUCT COLLAR LOCATED IN CENTER OR AT ANY POINT ALONG LENGTH OF THE PLENUM

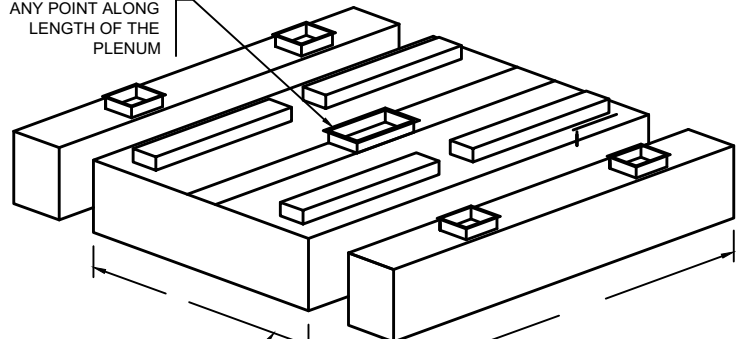

DIMENSION VARIES WITH DEPTH OF THE EQUIPMENT AND REQUIRED OVERHANG

14'-0" MAX. UNIT LENGTH. FOR GREATER LENGTH, JOIN TWO OR MORE UNITS TOGETHER. ALLOW 6" MIN. OVERHANG AT EACH END. IF CHARBROILER IS AT END, OVERHANG 12"

STANDARD LIGHT FIXTURES
 100 WATT INCANDESCENT
 RECESSED INCANDESCENT
 RECESSED FLUORESCENT
 (IF RECESSED FLUORESCENT SPECIFY SIZE)

CONSULT FACTORY FOR NON-STANDARD HEIGHTS
 22" MIN. FRONT OVERHANG
 6" MIN. SIDE OVERHANG
 (12" MIN. SIDE OVERHANG FOR CHARBROILER)

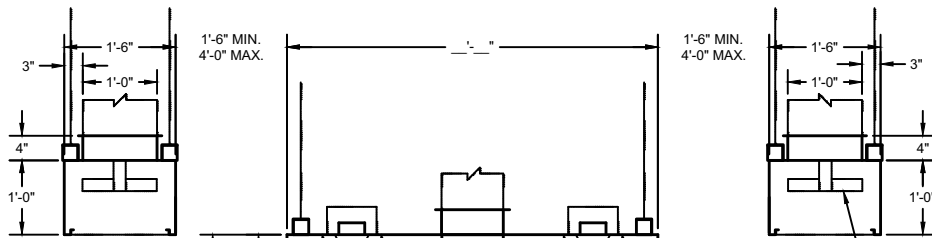

40% OPEN STN./STL. PERFORATED DIFFUSER

ITEM #	_____
EST. WEIGHT	_____
LENGTH	_____
WIDTH	_____
HEIGHT	_____
EXHAUST-CFM	_____
DUCT SIZE	_____
S.P.	_____

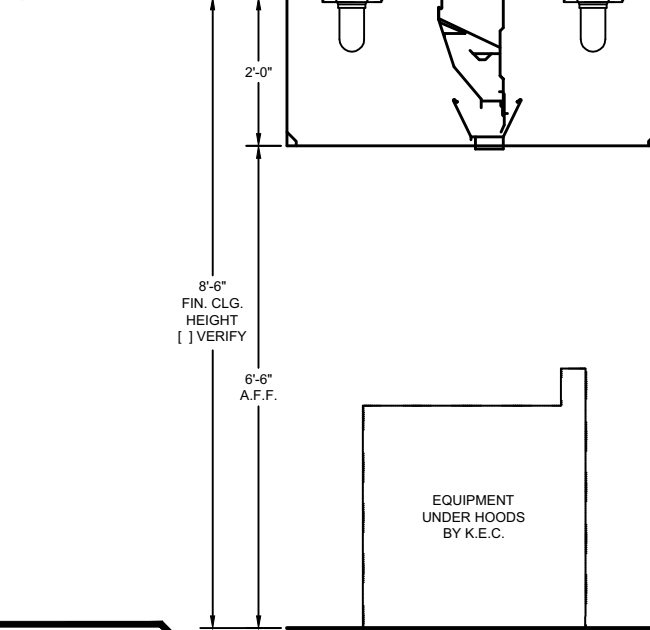

DRAWINGS NOT TO SCALE

ENGINEERING DATA

Ventilator Length

Maximum ventilator length in a single section is 14'-0". For lengths greater than 14'-0", join two or more sections. Verify access conditions into building and kitchen space prior to length selection.

Ventilator Hanging Weight

Wt./ lineal ft.	Lbs.	90
-----------------	------	----

NOTE: Refer to CADDY AirSystems

Master Engineering Data Sheet in engineering data section for determining light, medium, and heavy duty cooking equipment, C.F.M. requirements (exhaust and supply), duct collar sizes and static pressure requirements.

Electrical Requirements

Light fixtures to be powered by a 120/1/60 circuit.

Mechanical Requirements

The volume of exhaust required is a function of the type of cooking equipment served by the ventilator, and the type and volume of product cooked. Refer to the **CADDY AirSystems**

Master Engineering Data Chart to determine exhaust volume, duct collar sizes, static pressure drop.





CADDY CORPORATION

Food Service Equipment

Air Systems

Commercial Kitchen Exhaust Systems

Model SHC
Eyebrow Style

Model SHC-BK-W

Dry Cartridge Ventilator

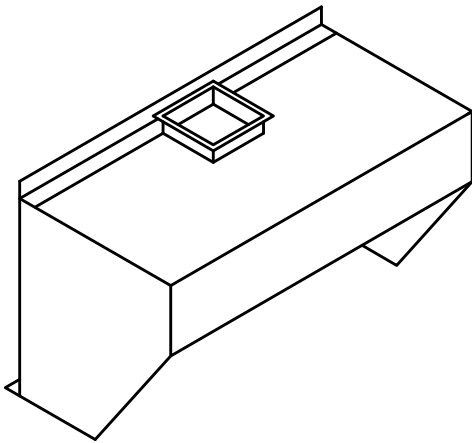

General Specifications

Furnish CADDY *AirSystems* Exhaust Hood Model **SHC-BK-W** as shown on the plans and as described in the following specifications.

General

Exhaust Ventilator shall be constructed of 18 gauge type 300 series stainless steel. All exposed surfaces to have a #4 finish. Construction to meet all requirements of NFPA 96 and NSF Standard No. 2. To include necessary hanger brackets at front and rear suspending from building overhead structure.

Description

The CADDY *AirSystems* Model "SHC" Ventilator is a dry extractor cartridge type and is UL listed under the standards as set forth in UL710 "Exhaust Hoods for Commercial Cooking Equipment." This ventilator is 95% grease extraction efficient when operated and maintained in accordance with design specifications. This high efficiency is accomplished by utilizing removable stainless steel extractor cartridges containing a series of horizontal, self-draining baffles. As the air is drawn around the baffles, the grease, dust and lint particles are slung from the air stream by centrifugal force. As the liquefied grease is extracted, it is drawined off via a trough into grease collection containers at each end of the ventilator. At the end of the cooking day or at scheduled intervals, the cartridges are removed for cleaning without having to climb up or onto the cooking equipment with the use of an extractor removal pot sink. Each cartridge is a maximum of 19-1/2" long. Ventilator can also be quipped with an optional fusible link or thermostatically activated fire damper assembly.

Application

Eye brow style for direct mounting to roast, bake, reel and pizza ovens.

Exhaust Fans

Exhaust fans are to be provided and installed by others in compliance with local codes. **Fans should be induced draft, squirrel cage design, equipped with backward inclined blades.**

Fire Protection

NFPA 96 and local codes require a fire extinguishing system for protection of the duct collar and plenum of all ventilators, as well as for the protection of various cooking appliances such as deep fat fryers, griddles, ranges, and broilers, which may be a source of ignition of grease. Consult factory and local fire officials for exact requirements. UL Listed fire protection systems may be pre-piped by Caddy at the time of manufacture, assuring concealment of piping and detectors.

Approvals

Ventilator shall be UL Listed, listed by NSF and be in accordance with all of the recommendations set forth by NFPA 96. All ventilators must meet all applicable codes.



MODEL:

SHC-BK-W- - -

ADD THE OVERALL LENGTH (IN INCHES) OF THE VENTILATOR AFTER MODEL DESIGNATION

DAMPER TYPE
ND - NO DAMPER
FL - FUSIBLE LINK
T - THERMOSTAT

ADD THE OVERALL WIDTH (IN INCHES) OF THE VENTILATOR AFTER MODEL DESIGNATION

STANDARD LIGHT FIXTURES
() 100 WATT INCANDESCENT
() RECESSED INCANDESCENT
() RECESSED FLUORESCENT
(IF RECESSED FLUORESCENT SPECIFY SIZE)

CONSULT FACTORY FOR NON-STANDARD HEIGHTS

ITEM #	_____
EST. WEIGHT	_____
LENGTH	_____
WIDTH	_____
HEIGHT	_____
EXHAUST-CFM	_____
DUCT SIZE	_____
S.P.	_____

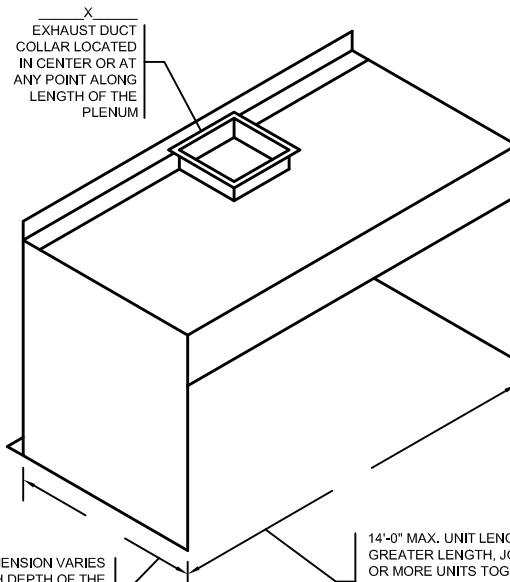

DIMENSION VARIES WITH DEPTH OF THE EQUIPMENT AND REQUIRED OVERHANG

14'-0" MAX. UNIT LENGTH. FOR GREATER LENGTH, JOIN TWO OR MORE UNITS TOGETHER. ALLOW 8" MIN. OVERHANG AT EACH END. IF CHARBROILER IS AT END, OVERHANG 12"

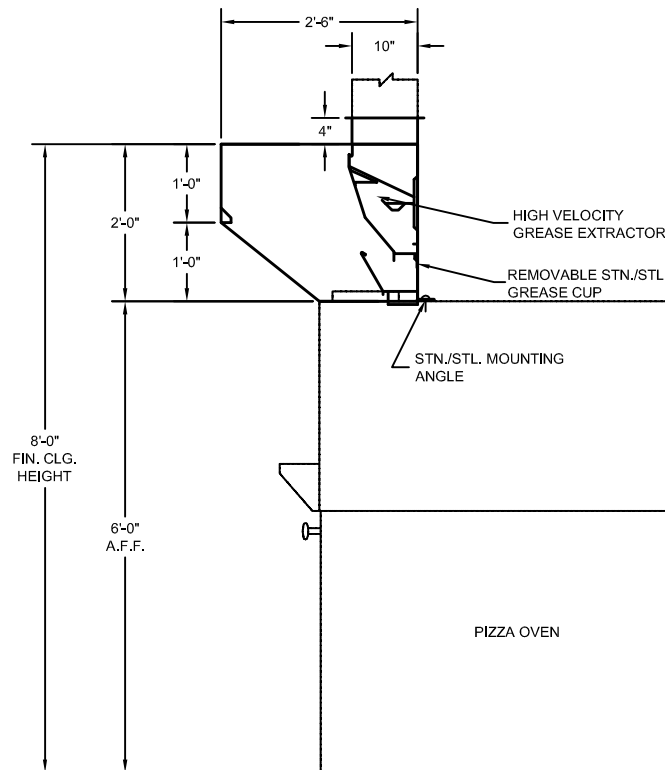

SECTION

DRAWINGS NOT TO SCALE

ENGINEERING DATA

Ventilator Length

Maximum ventilator length in a single section is 14'-0". For lengths greater than 14'-0", join two or more sections. Verify access conditions into building and kitchen space prior to length selection.

Ventilator Hanging Weight

Wt./ lineal ft.	Lbs.	65
-----------------	------	----

NOTE: Refer to **CADDY AirSystems**

Master Engineering Data Sheet in engineering data section for determining light, medium, and heavy duty cooking equipment, C.F.M. requirements (exhaust and supply), duct collar sizes and static pressure requirements.

Electrical Requirements

Light fixtures to be powered by a 120/1/60 circuit.

Mechanical Requirements

The volume of exhaust required is a function of the type of cooking equipment served by the ventilator, and the type and volume of product cooked. Refer to the **CADDY AirSystems**

Master Engineering Data Chart to determine exhaust volume, duct collar sizes, static pressure drop.





CADDY CORPORATION

Food Service Equipment

Air Systems

Commercial Kitchen Exhaust Systems

Model SHC
Backshelf Style

Model SHC-BK-W Dry Cartridge Ventilator

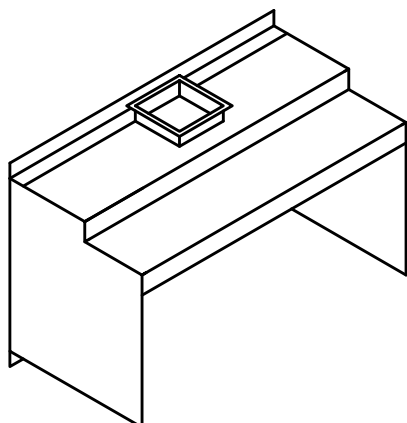

General Specifications

Furnish CADDY *AirSystems* Exhaust Hood Model **SHC-BK-W** as shown on the plans and as described in the following specifications.

General

Exhaust Ventilator shall be constructed of 18 gauge type 300 series stainless steel. All exposed surfaces to have a #4 finish. Construction to meet all requirements of NFPA 96 and NSF Standard No. 2. To include necessary hanger brackets at front and rear suspending from building overhead structure.

Description

The CADDY *AirSystems* Model "SHC" Ventilator is a dry extractor cartridge type and is UL listed under the standards as set forth in UL710 "Exhaust Hoods for Commercial Cooking Equipment." This ventilator is 95% grease extraction efficient when operated and maintained in accordance with design specifications. This high efficiency is accomplished by utilizing removable stainless steel extractor cartridges containing a series of horizontal, self-draining baffles. As the air is drawn around the baffles, the grease, dust and lint particles are slung from the air stream by centrifugal force. As the liquefied grease is extracted, it is drawined off via a trough into grease collection containers at each end of the ventilator. At the end of the cooking day or at scheduled intervals, the cartridges are removed for cleaning without having to climb up or onto the cooking equipment with the use of an extractor removal pot sink. Each cartridge is a maximum of 19-1/2" long. Ventilator can also be quipped with an optional fusible link or thermostatically activated fire damper assembly.

Application

Backshelf style for use over all types of cooking equipment 36" high or less. The shelf of the ventilator shall serve as a plate or pan storage area.

Exhaust Fans

Exhaust fans are to be provided and installed by others in compliance with local codes. **Fans should be induced draft, squirrel cage design, equipped with backward inclined blades.**

Fire Protection

NFPA 96 and local codes require a fire extinguishing system for protection of the duct collar and plenum of all ventilators, as well as for the protection of various cooking appliances such as deep fat fryers, griddles, ranges, and broilers, which may be a source of ignition of grease. Consult factory and local fire officials for exact requirements. UL Listed fire protection systems may be pre-piped by Caddy at the time of manufacture, assuring concealment of piping and detectors.

Approvals

Ventilator shall be UL Listed, listed by NSF and be in accordance with all of the recommendations set forth by NFPA 96. All ventilators must meet all applicable codes.



MODEL:

SHC-BK-W---

ADD THE OVERALL LENGTH (IN INCHES) OF THE VENTILATOR AFTER MODEL DESIGNATION

DAMPER TYPE
ND - NO DAMPER
FL - FUSIBLE LINK
T - THERMOSTAT

ADD THE OVERALL WIDTH (IN INCHES) OF THE VENTILATOR AFTER MODEL DESIGNATION

STANDARD LIGHT FIXTURES
 100 WATT INCANDESCENT
 RECESSED INCANDESCENT
 RECESSED FLUORESCENT
 (IF RECESSED FLUORESCENT SPECIFY SIZE)

CONSULT FACTORY FOR NON-STANDARD HEIGHTS

ITEM # _____
 EST. WEIGHT _____
 LENGTH _____
 WIDTH _____
 HEIGHT _____
 EXHAUST-CFM _____
 DUCT SIZE _____
 S.P. _____

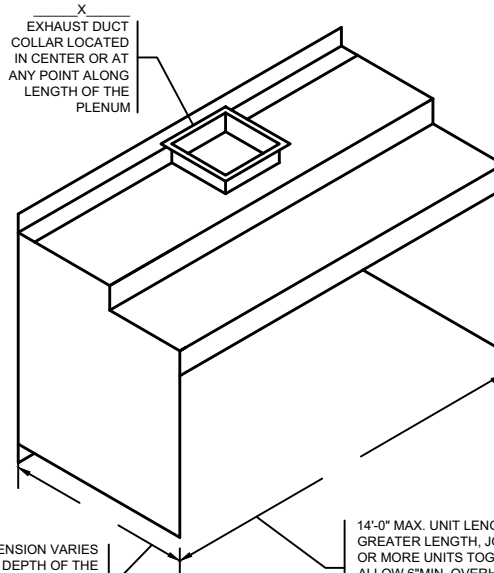

DIMENSION VARIES WITH DEPTH OF THE EQUIPMENT AND REQUIRED OVERHANG

14'-0" MAX. UNIT LENGTH. FOR GREATER LENGTH, JOIN TWO OR MORE UNITS TOGETHER. ALLOW 6" MIN. OVERHANG AT EACH END. IF CHARBROILER IS AT END, OVERHANG 12"

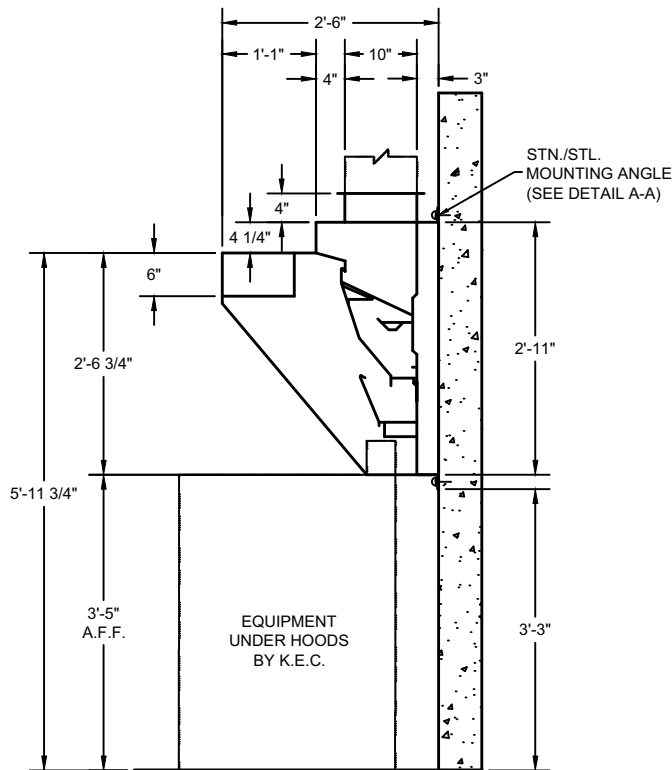

SECTION Z-Z

DRAWINGS NOT TO SCALE

ENGINEERING DATA

Ventilator Length

Maximum ventilator length in a single section is 14'-0". For lengths greater than 14'-0", join two or more sections. Verify access conditions into building and kitchen space prior to length selection.

Ventilator Hanging Weight

Wt./ lineal ft.	Lbs.	65
-----------------	------	----

NOTE: Refer to CADDY AirSystems

Master Engineering Data Sheet in engineering data section for determining light, medium, and heavy duty cooking equipment, C.F.M. requirements (exhaust and supply), duct collar sizes and static pressure requirements.

Electrical Requirements

Light fixtures to be powered by a 120/1/60 circuit.

Mechanical Requirements

The volume of exhaust required is a function of the type of cooking equipment served by the ventilator, and the type and volume of product cooked. Refer to the **CADDY AirSystems**

Master Engineering Data Chart to determine exhaust volume, duct collar sizes, static pressure drop.





CADDY CORPORATION

Food Service Equipment

Air Systems

Commercial Kitchen Exhaust Systems

Model SHW

Water-Wash Style



CADDY CORPORATION

Food Service Equipment

Air Systems

Commercial Kitchen Exhaust Systems

Model SHW
Wall Mount Style

Model SHW-C-W Waterwash Ventilator

ITEM NO:

PROJECT:

LOCATION:

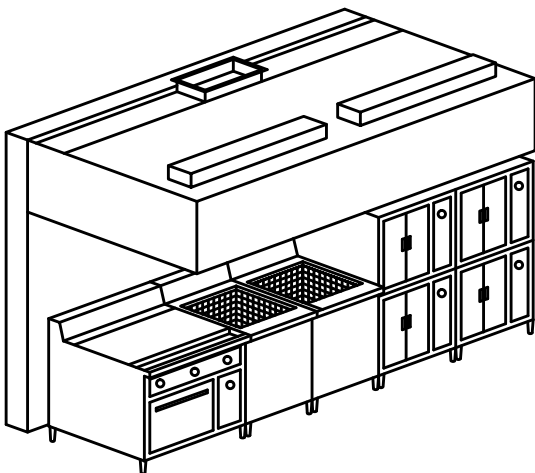

General Specifications

Furnish CADDY *AirSystems* Exhaust Hood Model **SHW-C-W** as shown on the plans and as described in the following specifications.

General

Exhaust hood shall be constructed of 18 gauge type 300 series stainless steel. All exposed surfaces to have a number # 4 finish. Construction to meet all requirements of NFPA 96 and NSF Standard No.2. To include necessary hanger brackets at front and rear for suspending from building overhead structure.

Description

The CADDY *AirSystems* Model "SHW" Ventilator is a water-wash type and is UL Listed under the standards set forth in UL 710 "Exhaust Hoods for Commercial Cooking Equipment". This ventilator is 95% grease extraction efficient when operated and maintained in accordance with design specifications. This high efficiency is accomplished by utilizing a high velocity centrifugal grease extractor, with the air inlet opening parallel to the cooking equipment it serves. Each ventilator shall have three full-length horizontal baffles for centrifugal grease extraction and shall be equipped with one full-length wash manifold with upper and lower brass spray nozzles for superior extraction. Ventilators shall operate at air quantities as illustrated on plans.

Accessibility and Inspection

Full length removable inspection doors shall be provided so that service can be performed on all interior components.

Automatic Washdown System

Ventilator to be equipped with one full length wash manifold with spray nozzles for automatic detergent injected wash using 140°F to 180°F hot water. Plumbing and electrical components for operation of the automatic wash system to be housed in the CADDY *AirSystems* Model "CPE" control panel.

Plumbing/Electrical

Ventilators to be factory pre-plumbed and pre-wired to a single connection point. Ventilators built in multiple sections to be furnished with unions and junction boxes for field connections by applicable trades.

Application

Wall mounted exhaust-only canopy style for use over all types of cooking equipment.

Light Fixtures

All light fixtures shall be pre-wired to a single connection point. Ventilators built in multiple sections to be furnished with junction boxes for ease of field connection by the electrical trades. Light bulbs furnished and installed by the Kitchen Equipment Contractor.

Exhaust Fans

Exhaust fans are to be provided and installed by others in compliance with local codes. **Fans should be induced draft, squirrel cage design, equipped with backward inclined blades.**

Fire Protection

NFPA 96 and local codes require a fire extinguishing system for protection of the duct collar and plenum of all ventilators, as well as for the protection of various cooking appliances such as deep fat fryers, griddles, ranges, and broilers, which may be a source of ignition of grease. Consult factory and local fire officials for exact requirements. UL Listed fire protection systems may be pre-piped by Caddy at the time of manufacture, assuring concealment of piping and detectors.

Approvals

Ventilator shall be UL Listed, listed by NSF and be in accordance with all of the recommendations set forth by NFPA 96. All ventilators must meet all applicable codes.



MODEL:

SHW-C-W - -

ADD THE OVERALL LENGTH (IN INCHES) OF THE VENTILATOR AFTER MODEL DESIGNATION

DAMPER TYPE
ND - NO DAMPER
FL - FUSIBLE LINK
T - THERMOSTAT

ADD THE OVERALL WIDTH (IN INCHES) OF THE VENTILATOR AFTER MODEL DESIGNATION

X
EXHAUST DUCT COLLAR LOCATED IN CENTER OR AT ANY POINT ALONG LENGTH OF THE PLENUM

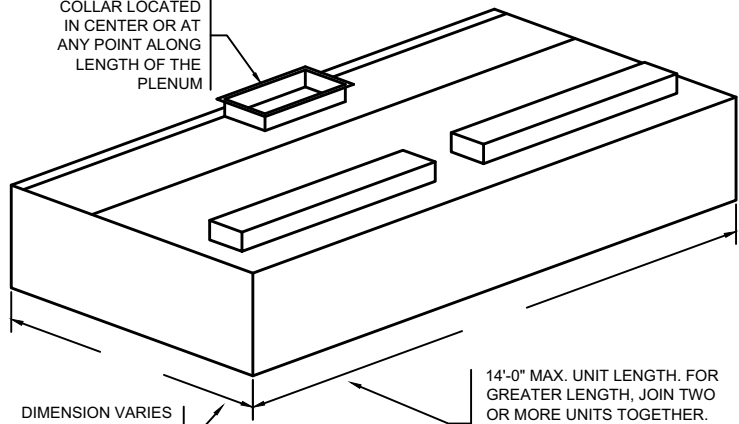

14'-0" MAX. UNIT LENGTH. FOR GREATER LENGTH, JOIN TWO OR MORE UNITS TOGETHER. ALLOW 6" MIN. OVERHANG AT EACH END. IF CHARBROILER IS AT END, OVERHANG 12"

DIMENSION VARIES WITH DEPTH OF THE EQUIPMENT AND REQUIRED OVERHANG

STANDARD LIGHT FIXTURES
 100 WATT INCANDESCENT
 RECESSED INCANDESCENT
 RECESSED FLUORESCENT
 (IF RECESSED FLUORESCENT SPECIFY SIZE)

CONSULT FACTORY FOR NON-STANDARD HEIGHTS
 12" MIN. FRONT OVERHANG
 6" MIN. SIDE OVERHANG
 (12" MIN. SIDE OVERHANG FOR CHARBROILER)

ITEM # _____
 EST. WEIGHT _____
 LENGTH _____
 WIDTH _____
 HEIGHT _____
 EXHAUST-CFM _____
 DUCT SIZE _____
 S.P. _____
 H.W. INLET SIZE _____
 DRAIN SIZE _____
 _____ GPM @ 40 PSI
 WATER TEMP 140°F - 180°F
 NOTE: 5 MIN. WASH CYCLE PER 24 HR PERIOD

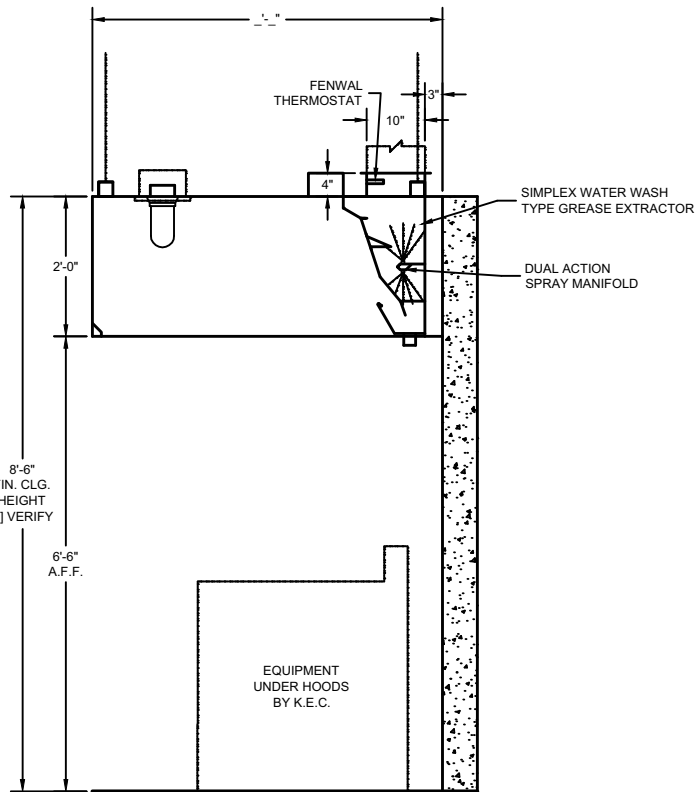

SECTION

DRAWINGS NOT TO SCALE

ENGINEERING DATA

Ventilator Length

Maximum ventilator length in a single section is 14'-0". For lengths greater than 14'-0", join two or more sections. Verify access conditions into building and kitchen space prior to length selection.

Ventilator Hanging Weight

Wt./ lineal ft.	Lbs.	90

NOTE: Refer to **CADDY AirSystems** Master Engineering Data Sheet in engineering data section for determining light, medium, and heavy duty cooking equipment, C.F.M. requirements (exhaust and supply), duct collar sizes and static pressure requirements.

Electrical Requirements

Provide 120 volt, single phase, 60 hertz, 15 amp (min.) 24 hour service to **CADDY AirSystems** CPE control panel (refer to CPE engineering cut sheet). Control panel to be fused separately. Light fixtures to be powered by a 120/1/60 circuit.

Mechanical Requirements

The volume of exhaust required is a function of the type of cooking equipment served by the ventilator, and the type and volume of product cooked. Refer to the **CADDY AirSystems** Master Engineering Data Chart to determine exhaust volume, duct collar sizes, static pressure drop, water consumption and ventilator drain sizes.



Model SHW-C-W-PA Waterwash Ventilator

ITEM NO:

PROJECT:

LOCATION:

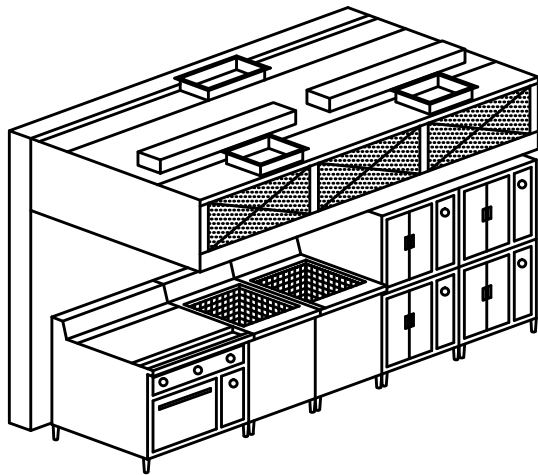

General Specifications

Furnish CADDY *AirSystems* Exhaust Hood Model **SHW-C-W-PA** as shown on the plans and as described in the following specifications.

General

Exhaust hood shall be constructed of 18 gauge type 300 series stainless steel. All exposed surfaces to have a number # 4 finish. Construction to meet all requirements of NFPA 96 and NSF Standard No.2. To include necessary hanger brackets at front and rear for suspending from building overhead structure.

Description

The CADDY *AirSystems* Model "SHW" Ventilator is a water-wash type and is UL Listed under the standards set forth in UL 710 "Exhaust Hoods for Commercial Cooking Equipment". This ventilator is 95% grease extraction efficient when operated and maintained in accordance with design specifications. This high efficiency is accomplished by utilizing a high velocity centrifugal grease extractor, with the air inlet opening parallel to the cooking equipment it serves. Each ventilator shall have three full-length horizontal baffles for centrifugal grease extraction and shall be equipped with one full-length wash manifold with upper and lower brass spray nozzles for superior extraction. Ventilators shall operate at air quantities as illustrated on plans.

Accessibility and Inspection

Full length removable inspection doors shall be provided so that service can be performed on all interior components.

Automatic Washdown System

Ventilator to be equipped with one full length wash manifold with spray nozzles for automatic detergent injected wash using 140°F to 180°F hot water. Plumbing and electrical components for operation of the automatic wash system to be housed in the CADDY *AirSystems* Model "CPE" control panel.

Plumbing/Electrical

Ventilators to be factory pre-plumbed and pre-wired to a single connection point. Ventilators built in multiple sections to be furnished with unions and junction boxes for field connections by applicable trades.

Make-Up Air (Front Face Discharge)

Ventilator shall have 40% open stainless steel perforated screens along front face for face discharge of tempered make-up air. This type of make-up air is the most common and advantageous method of bringing air into the kitchen via the kitchen exhaust ventilator. Typically supply volume is 80%, or more depending upon the desired air balance. Supply air temperature should range from 60°F - 65°F, but may be as low as 50°F, depending on air volume, distribution, internal heat load, and desired ambient room temperature.

Application

Wall mounted canopy style for use over all types of cooking equipment where integral make-up air is required.

Light Fixtures

All light fixtures shall be pre-wired to a single connection point. Ventilators built in multiple sections to be furnished with junction boxes for ease of field connection by the electrical trades. Light bulbs furnished and installed by the Kitchen Equipment Contractor.

Exhaust Fans

Exhaust fans are to be provided and installed by others in compliance with local codes. **Fans should be induced draft, squirrel cage design, equipped with backward inclined blades.**

Fire Protection

NFPA 96 and local codes require a fire extinguishing system for protection of the duct collar and plenum of all ventilators, as well as for the protection of various cooking appliances such as deep fat fryers, griddles, ranges, and broilers, which may be a source of ignition of grease. Consult factory and local fire officials for exact requirements. UL Listed fire protection systems may be pre-piped by Caddy at the time of manufacture, assuring concealment of piping and detectors.

Approvals

Ventilator shall be UL Listed, listed by NSF and be in accordance with all of the recommendations set forth by NFPA 96. All ventilators must meet all applicable codes.





MODEL:

SHW-C-W-PA---

ADD THE OVERALL LENGTH (IN INCHES) OF THE VENTILATOR AFTER MODEL DESIGNATION

DAMPER TYPE
ND - NO DAMPER
FL - FUSIBLE LINK
T - THERMOSTAT

ADD THE OVERALL WIDTH (IN INCHES) OF THE VENTILATOR AFTER MODEL DESIGNATION

X
EXHAUST DUCT COLLAR LOCATED IN CENTER OR AT ANY POINT ALONG LENGTH OF THE PLENUM

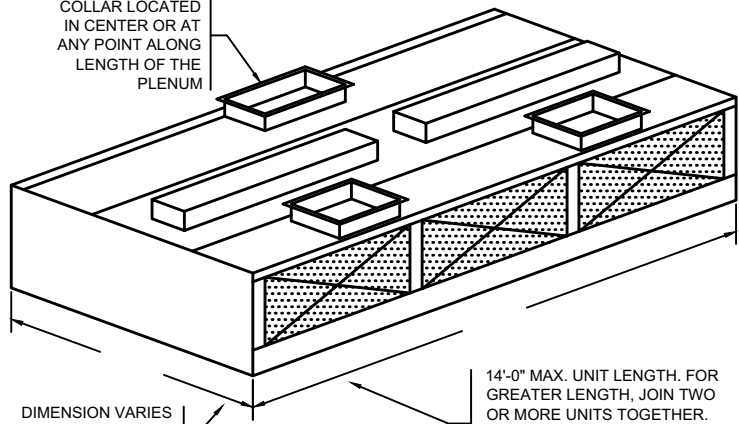

14'-0" MAX. UNIT LENGTH. FOR GREATER LENGTH, JOIN TWO OR MORE UNITS TOGETHER. ALLOW 6" MIN. OVERHANG AT EACH END. IF CHARBROILER IS AT END, OVERHANG 12"

DIMENSION VARIES WITH DEPTH OF THE EQUIPMENT AND REQUIRED OVERHANG

STANDARD LIGHT FIXTURES
 100 WATT INCANDESCENT
 RECESSED INCANDESCENT
 RECESSED FLUORESCENT
 (IF RECESSED FLUORESCENT SPECIFY SIZE)

CONSULT FACTORY FOR NON-STANDARD HEIGHTS
 12" MIN. FRONT OVERHANG
 6" MIN. SIDE OVERHANG
 (12" MIN. SIDE OVERHANG FOR CHARBROILER)

ITEM # _____
 EST. WEIGHT _____
 LENGTH _____
 WIDTH _____
 HEIGHT _____
 EXHAUST-CFM _____
 DUCT SIZE _____
 S.P. _____
 H.W. INLET SIZE _____
 DRAIN SIZE _____
 _____ GPM @ 40 PSI
 WATER TEMP 140°F - 180°F
 NOTE: 5 MIN. WASH CYCLE PER 24 HR PERIOD

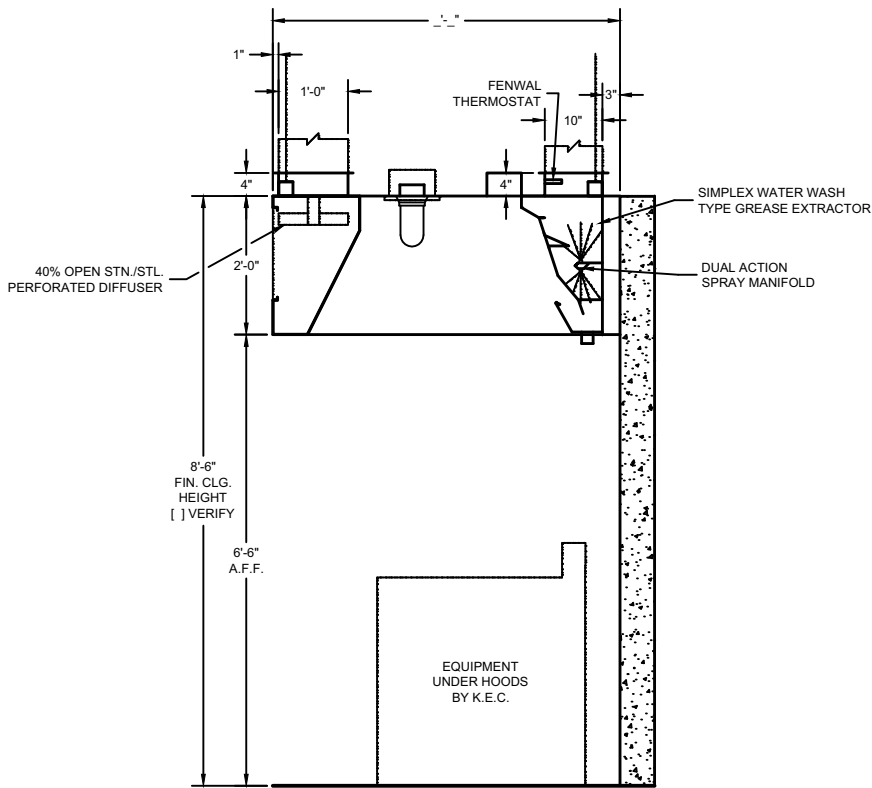

SECTION

DRAWINGS NOT TO SCALE

ENGINEERING DATA

Ventilator Length

Maximum ventilator length in a single section is 14'-0". For lengths greater than 14'-0", join two or more sections. Verify access conditions into building and kitchen space prior to length selection.

Ventilator Hanging Weight

Wt./lineal ft.	Lbs.	105
----------------	------	-----

NOTE: Refer to CADDY AirSystems

Master Engineering Data Sheet in engineering data section for determining light, medium, and heavy duty cooking equipment, C.F.M. requirements (exhaust and supply), duct collar sizes and static pressure requirements.

Electrical Requirements

Provide 120 volt, single phase, 60 hertz, 15 amp (min.) 24 hour service to **CADDY AirSystems** CPE control panel (refer to CPE engineering cut sheet). Control panel to be fused separately. Light fixtures to be powered by a 120/1/60 circuit.

Mechanical Requirements

The volume of exhaust required is a function of the type of cooking equipment served by the ventilator, and the type and volume of product cooked. Refer to the **CADDY AirSystems** Master Engineering Data Chart to determine exhaust volume, duct collar sizes, static pressure drop, water consumption and ventilator drain sizes.



Model SHW-C-W-ASI Waterwash Ventilator

ITEM NO:

PROJECT:

LOCATION:

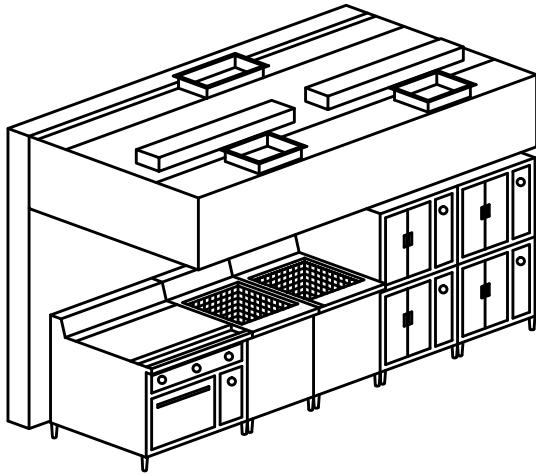

General Specifications

Furnish CADDY *AirSystems* Exhaust Hood Model **SHW-C-W-ASI** as shown on the plans and as described in the following specifications.

General

Exhaust hood shall be constructed of 18 gauge type 300 series stainless steel. All exposed surfaces to have a number # 4 finish. Construction to meet all requirements of NFPA 96 and NSF Standard No.2. To include necessary hanger brackets at front and rear for suspending from building overhead structure.

Description

The CADDY *AirSystems* Model "SHW" Ventilator is a water-wash type and is UL Listed under the standards set forth in UL 710 "Exhaust Hoods for Commercial Cooking Equipment". This ventilator is 95% grease extraction efficient when operated and maintained in accordance with design specifications. This high efficiency is accomplished by utilizing a high velocity centrifugal grease extractor, with the air inlet opening parallel to the cooking equipment it serves. Each ventilator shall have three full-length horizontal baffles for centrifugal grease extraction and shall be equipped with one full-length wash manifold with upper and lower brass spray nozzles for superior extraction. Ventilators shall operate at air quantities as illustrated on plans.

Accessibility and Inspection

Full length removable inspection doors shall be provided so that service can be performed on all interior components.

Automatic Washdown System

Ventilator to be equipped with one full length wash manifold with spray nozzles for automatic detergent injected wash using 140°F to 180°F hot water. Plumbing and electrical components for operation of the automatic wash system to be housed in the CADDY *AirSystems* Model "CPE" control panel.

Plumbing/Electrical

Ventilators to be factory pre-plumbed and pre-wired to a single connection point. Ventilators built in multiple sections to be furnished with unions and junction boxes for field connections by applicable trades.

Make-Up Air (Internal Discharge)

Ventilator shall have a fully insulated supply plenum, with duct collar/fire damper assemblies, and air registers internally mounted for discharging untempered make-up air directly into canopy of ventilator. The amount of make-up air supplied through this design is directly related to the type of cooking equipment located beneath the hood. The percentage of supply air distributed will vary as a function of the thermal currents generated by each individual appliance. When specifying this style, consult factory for specific supply volumes. This air may be untempered in most areas, depending upon climatic conditions and the type of cooking equipment. If the design temperature is below 10°F, consult factory for supply volumes and design considerations.

Application

Wall mounted canopy style for use over all types of cooking equipment where integral make-up air is required.

Light Fixtures

All light fixtures shall be pre-wired to a single connection point. Ventilators built in multiple sections to be furnished with junction boxes for ease of field connection by the electrical trades. Light bulbs furnished and installed by the Kitchen Equipment Contractor.

Exhaust Fans

Exhaust fans are to be provided and installed by others in compliance with local codes. **Fans should be induced draft, squirrel cage design, equipped with backward inclined blades.**

Fire Protection

NFPA 96 and local codes require a fire extinguishing system for protection of the duct collar and plenum of all ventilators, as well as for the protection of various cooking appliances such as deep fat fryers, griddles, ranges, and broilers, which may be a source of ignition of grease. Consult factory and local fire officials for exact requirements. UL Listed fire protection systems may be pre-piped by Caddy at the time of manufacture, assuring concealment of piping and detectors.

Approvals

Ventilator shall be UL Listed, listed by NSF and be in accordance with all of the recommendations set forth by NFPA 96. All ventilators must meet all applicable codes.





MODEL:

SHW-C-W-ASI---

ADD THE OVERALL LENGTH (IN INCHES) OF THE VENTILATOR AFTER MODEL DESIGNATION

DAMPER TYPE
ND - NO DAMPER
FL - FUSIBLE LINK
T - THERMOSTAT

ADD THE OVERALL WIDTH (IN INCHES) OF THE VENTILATOR AFTER MODEL DESIGNATION

X
EXHAUST DUCT COLLAR LOCATED IN CENTER OR AT ANY POINT ALONG LENGTH OF THE PLENUM

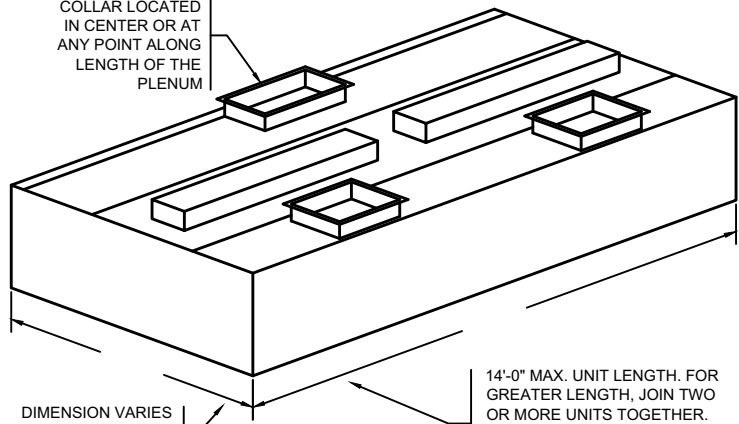

14'-0" MAX. UNIT LENGTH. FOR GREATER LENGTH, JOIN TWO OR MORE UNITS TOGETHER. ALLOW 6" MIN. OVERHANG AT EACH END. IF CHARBROILER IS AT END, OVERHANG 12"

DIMENSION VARIES WITH DEPTH OF THE EQUIPMENT AND REQUIRED OVERHANG

STANDARD LIGHT FIXTURES
 100 WATT INCANDESCENT
 RECESSED INCANDESCENT
 RECESSED FLUORESCENT
 (IF RECESSED FLUORESCENT SPECIFY SIZE)

CONSULT FACTORY FOR NON-STANDARD HEIGHTS
 22" MIN. FRONT OVERHANG
 6" MIN. SIDE OVERHANG
 (12" MIN. SIDE OVERHANG FOR CHARBROILER)

ITEM # _____
 EST. WEIGHT _____
 LENGTH _____
 WIDTH _____
 HEIGHT _____
 EXHAUST-CFM _____
 DUCT SIZE _____
 S.P. _____
 H.W. INLET SIZE _____
 DRAIN SIZE _____
 _____ GPM @ 40 PSI
 WATER TEMP 140°F - 180°F
 NOTE: 5 MIN. WASH CYCLE PER 24 HR PERIOD

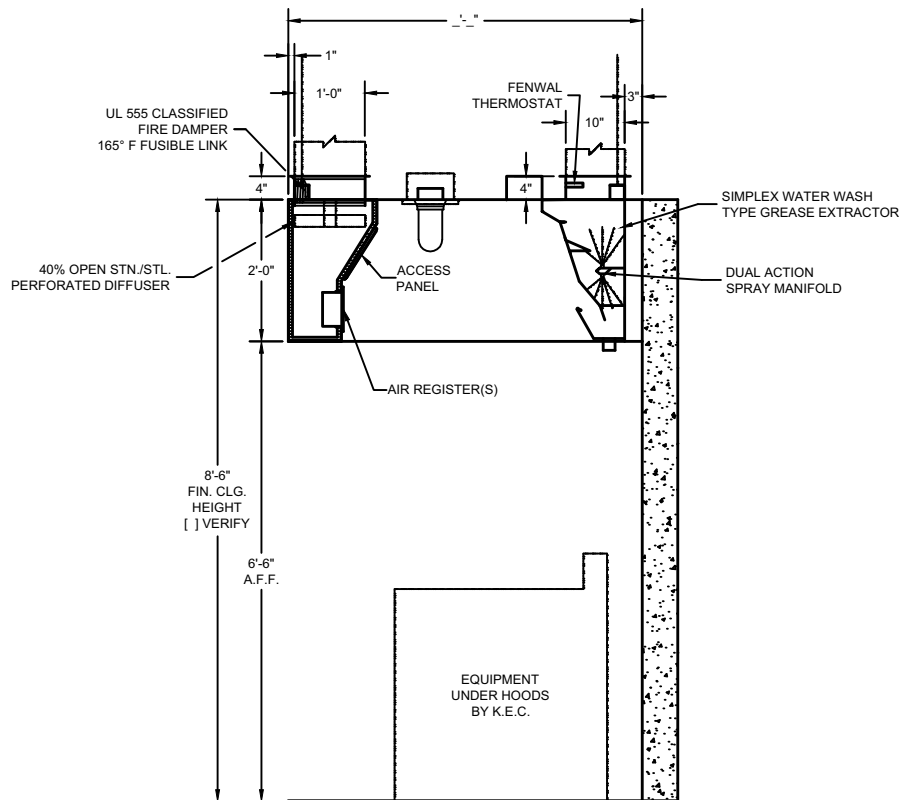

SECTION

DRAWINGS NOT TO SCALE

ENGINEERING DATA

Ventilator Length

Maximum ventilator length in a single section is 14'-0". For lengths greater than 14'-0", join two or more sections. Verify access conditions into building and kitchen space prior to length selection.

Ventilator Hanging Weight

Wt./ lineal ft.	Lbs.	105
-----------------	------	-----

NOTE: Refer to CADDY AirSystems

Master Engineering Data Sheet in engineering data section for determining light, medium, and heavy duty cooking equipment, C.F.M. requirements (exhaust and supply), duct collar sizes and static pressure requirements.

Electrical Requirements

Provide 120 volt, single phase, 60 hertz, 15 amp (min.) 24 hour service to **CADDY AirSystems** CPE control panel (refer to CPE engineering cut sheet). Control panel to be fused separately. Light fixtures to be powered by a 120/1/60 circuit.

Mechanical Requirements

The volume of exhaust required is a function of the type of cooking equipment served by the ventilator, and the type and volume of product cooked. Refer to the **CADDY AirSystems** Master Engineering Data Chart to determine exhaust volume, duct collar sizes, static pressure drop, water consumption and ventilator drain sizes.



Model SHW-C-W-AA Waterwash Ventilator

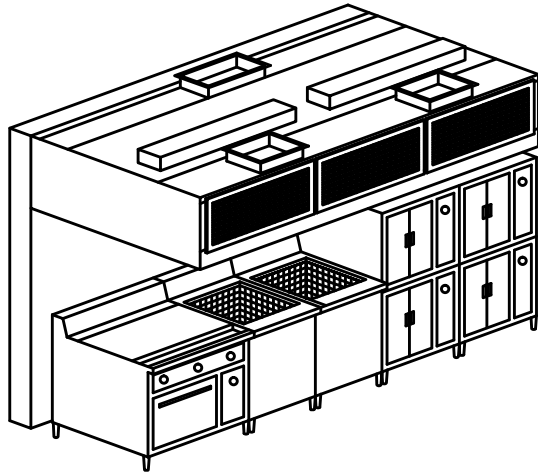

General Specifications

Furnish CADDY *AirSystems* Exhaust Hood Model **SHW-C-W-AA** as shown on the plans and as described in the following specifications.

General

Exhaust hood shall be constructed of 18 gauge type 300 series stainless steel. All exposed surfaces to have a number # 4 finish. Construction to meet all requirements of NFPA 96 and NSF Standard No.2. To include necessary hanger brackets at front and rear for suspending from building overhead structure.

Description

The CADDY *AirSystems* Model "SHW" Ventilator is a water-wash type and is UL Listed under the standards set forth in UL 710 "Exhaust Hoods for Commercial Cooking Equipment". This ventilator is 95% grease extraction efficient when operated and maintained in accordance with design specifications. This high efficiency is accomplished by utilizing a high velocity centrifugal grease extractor, with the air inlet opening parallel to the cooking equipment it serves. Each ventilator shall have three full-length horizontal baffles for centrifugal grease extraction and shall be equipped with one full-length wash manifold with upper and lower brass spray nozzles for superior extraction. Ventilators shall operate at air quantities as illustrated on plans.

Accessibility and Inspection

Full length removable inspection doors shall be provided so that service can be performed on all interior components.

Automatic Washdown System

Ventilator to be equipped with one full length wash manifold with spray nozzles for automatic detergent injected wash using 140°F to 180°F hot water. Plumbing and electrical components for operation of the automatic wash system to be housed in the CADDY *AirSystems* Model "CPE" control panel.

Plumbing/Electrical

Ventilators to be factory pre-plumbed and pre-wired to a single connection point. Ventilators built in multiple sections to be furnished with unions and junction boxes for field connections by applicable trades.

Make-Up Air (Front Face Discharge)

Ventilator shall have air registers along front face for face discharge of tempered make-up air. This type of make-up air is the most common and advantageous method of bringing air into the kitchen via the kitchen exhaust ventilator. Typically supply volume is 80%, or more depending upon the desired air balance. Supply air temperature should range from 60°F - 65°F, but may be as low as 50°F, depending on air volume, distribution, internal heat load, and desired ambient room temperature.

Application

Wall mounted canopy style for use over all types of cooking equipment where integral make-up air is required.

Light Fixtures

All light fixtures shall be pre-wired to a single connection point. Ventilators built in multiple sections to be furnished with junction boxes for ease of field connection by the electrical trades. Light bulbs furnished and installed by the Kitchen Equipment Contractor.

Exhaust Fans

Exhaust fans are to be provided and installed by others in compliance with local codes. **Fans should be induced draft, squirrel cage design, equipped with backward inclined blades.**

Fire Protection

NFPA 96 and local codes require a fire extinguishing system for protection of the duct collar and plenum of all ventilators, as well as for the protection of various cooking appliances such as deep fat fryers, griddles, ranges, and broilers, which may be a source of ignition of grease. Consult factory and local fire officials for exact requirements. UL Listed fire protection systems may be pre-piped by Caddy at the time of manufacture, assuring concealment of piping and detectors.

Approvals

Ventilator shall be UL Listed, listed by NSF and be in accordance with all of the recommendations set forth by NFPA 96. All ventilators must meet all applicable codes.



MODEL:

SHW-C-W-AA---

ADD THE OVERALL LENGTH (IN INCHES) OF THE VENTILATOR AFTER MODEL DESIGNATION

DAMPER TYPE
ND - NO DAMPER
FL - FUSIBLE LINK
T - THERMOSTAT

ADD THE OVERALL WIDTH (IN INCHES) OF THE VENTILATOR AFTER MODEL DESIGNATION

X
EXHAUST DUCT COLLAR LOCATED IN CENTER OR AT ANY POINT ALONG LENGTH OF THE PLENUM

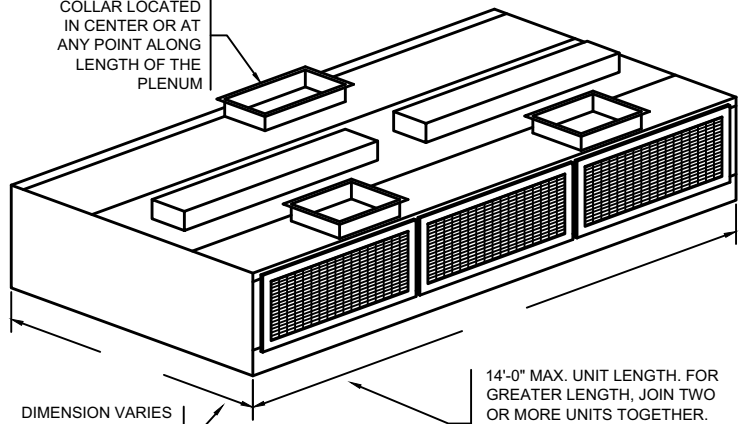

14'-0" MAX. UNIT LENGTH. FOR GREATER LENGTH, JOIN TWO OR MORE UNITS TOGETHER. ALLOW 6" MIN. OVERHANG AT EACH END. IF CHARBROILER IS AT END, OVERHANG 12"

DIMENSION VARIES WITH DEPTH OF THE EQUIPMENT AND REQUIRED OVERHANG

STANDARD LIGHT FIXTURES
 100 WATT INCANDESCENT
 RECESSED INCANDESCENT
 RECESSED FLUORESCENT
 (IF RECESSED FLUORESCENT SPECIFY SIZE)

CONSULT FACTORY FOR NON-STANDARD HEIGHTS
 12" MIN. FRONT OVERHANG
 6" MIN. SIDE OVERHANG (12" MIN. SIDE OVERHANG FOR CHARBROILER)

ITEM # _____
 EST. WEIGHT _____
 LENGTH _____
 WIDTH _____
 HEIGHT _____
 EXHAUST-CFM _____
 DUCT SIZE _____
 S.P. _____
 H.W. INLET SIZE _____
 DRAIN SIZE _____
 _____ GPM @ 40 PSI
 WATER TEMP 140°F - 180°F
 NOTE: 5 MIN. WASH CYCLE PER 24 HR PERIOD

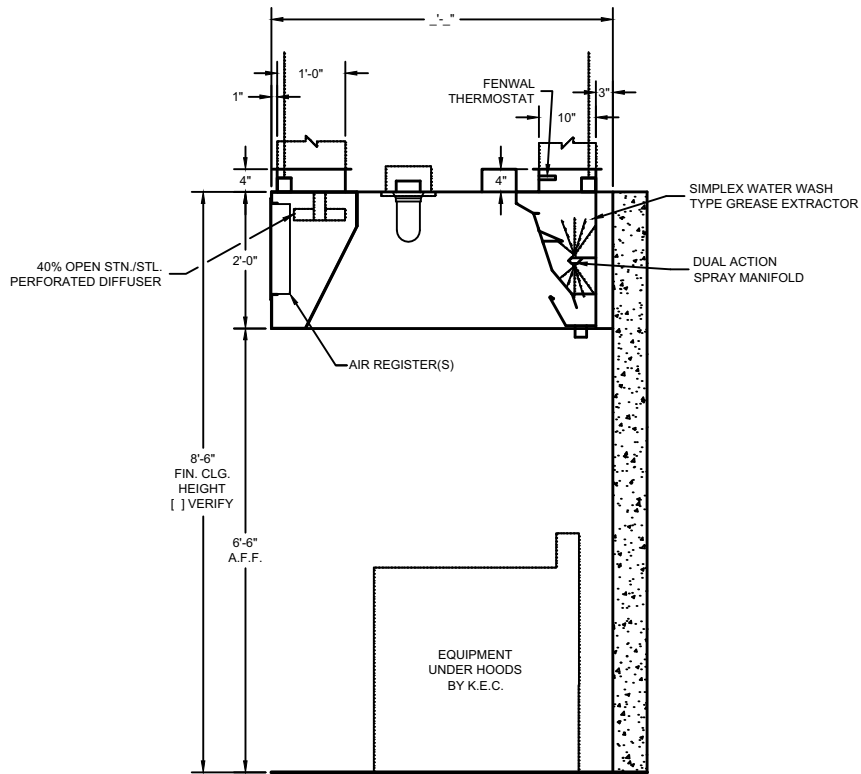

SECTION

DRAWINGS NOT TO SCALE

ENGINEERING DATA

Ventilator Length

Maximum ventilator length in a single section is 14'-0". For lengths greater than 14'-0", join two or more sections. Verify access conditions into building and kitchen space prior to length selection.

Ventilator Hanging Weight

Wt./ lineal ft.	Lbs.	105
-----------------	------	-----

NOTE: Refer to **CADDY AirSystems**

Master Engineering Data Sheet in engineering data section for determining light, medium, and heavy duty cooking equipment, C.F.M. requirements (exhaust and supply), duct collar sizes and static pressure requirements.

Electrical Requirements

Provide 120 volt, single phase, 60 hertz, 15 amp (min.) 24 hour service to **CADDY AirSystems** CPE control panel (refer to CPE engineering cut sheet). Control panel to be fused separately. Light fixtures to be powered by a 120/1/60 circuit.

Mechanical Requirements

The volume of exhaust required is a function of the type of cooking equipment served by the ventilator, and the type and volume of product cooked. Refer to the **CADDY AirSystems** Master Engineering Data Chart to determine exhaust volume, duct collar sizes, static pressure drop, water consumption and ventilator drain sizes.



Model SHW-C-W-ASII Waterwash Ventilator

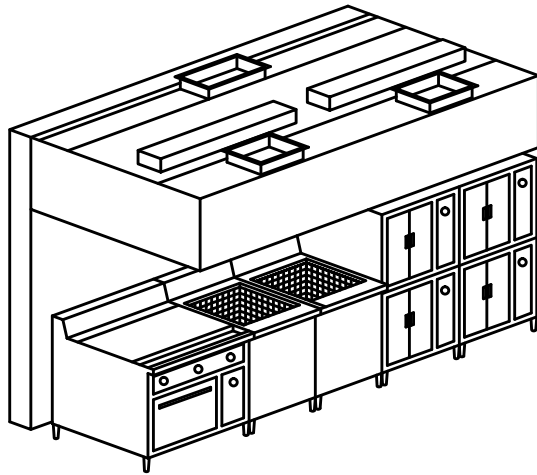

General Specifications

Furnish CADDY *AirSystems* Exhaust Hood Model **SHW-C-W-ASII** as shown on the plans and as described in the following specifications.

General

Exhaust hood shall be constructed of 18 gauge type 300 series stainless steel. All exposed surfaces to have a number # 4 finish. Construction to meet all requirements of NFPA 96 and NSF Standard No.2. To include necessary hanger brackets at front and rear for suspending from building overhead structure.

Description

The CADDY *AirSystems* Model "SHW" Ventilator is a water-wash type and is UL Listed under the standards set forth in UL 710 "Exhaust Hoods for Commercial Cooking Equipment". This ventilator is 95% grease extraction efficient when operated and maintained in accordance with design specifications. This high efficiency is accomplished by utilizing a high velocity centrifugal grease extractor, with the air inlet opening parallel to the cooking equipment it serves. Each ventilator shall have three full-length horizontal baffles for centrifugal grease extraction and shall be equipped with one full-length wash manifold with upper and lower brass spray nozzles for superior extraction. Ventilators shall operate at air quantities as illustrated on plans.

Accessibility and Inspection

Full length removable inspection doors shall be provided so that service can be performed on all interior components.

Automatic Washdown System

Ventilator to be equipped with one full length wash manifold with spray nozzles for automatic detergent injected wash using 140°F to 180°F hot water. Plumbing and electrical components for operation of the automatic wash system to be housed in the CADDY *AirSystems* Model "CPE" control panel.

Plumbing/Electrical

Ventilators to be factory pre-plumbed and pre-wired to a single connection point. Ventilators built in multiple sections to be furnished with unions and junction boxes for field connections by applicable trades.

Make-Up Air (Perimeter Down Discharge)

Up to 80% of the exhaust air may be supplied through this down discharge system. However, the air must be tempered to a minimum of 65°F to avoid discomfort to operations personnel.

Application

Wall mounted canopy style for use over all types of cooking equipment where integral make-up air is required.

Light Fixtures

All light fixtures shall be pre-wired to a single connection point. Ventilators built in multiple sections to be furnished with junction boxes for ease of field connection by the electrical trades. Light bulbs furnished and installed by the Kitchen Equipment Contractor.

Exhaust Fans

Exhaust fans are to be provided and installed by others in compliance with local codes. **Fans should be induced draft, squirrel cage design, equipped with backward inclined blades.**

Fire Protection

NFPA 96 and local codes require a fire extinguishing system for protection of the duct collar and plenum of all ventilators, as well as for the protection of various cooking appliances such as deep fat fryers, griddles, ranges, and broilers, which may be a source of ignition of grease. Consult factory and local fire officials for exact requirements. UL Listed fire protection systems may be pre-piped by Caddy at the time of manufacture, assuring concealment of piping and detectors.

Approvals

Ventilator shall be UL Listed, listed by NSF and be in accordance with all of the recommendations set forth by NFPA 96. All ventilators must meet all applicable codes.



MODEL:

SHW-C-W-ASII---

ADD THE OVERALL LENGTH (IN INCHES) OF THE VENTILATOR AFTER MODEL DESIGNATION

DAMPER TYPE
ND - NO DAMPER
FL - FUSIBLE LINK
T - THERMOSTAT

ADD THE OVERALL WIDTH (IN INCHES) OF THE VENTILATOR AFTER MODEL DESIGNATION

X
EXHAUST DUCT COLLAR LOCATED IN CENTER OR AT ANY POINT ALONG LENGTH OF THE PLENUM

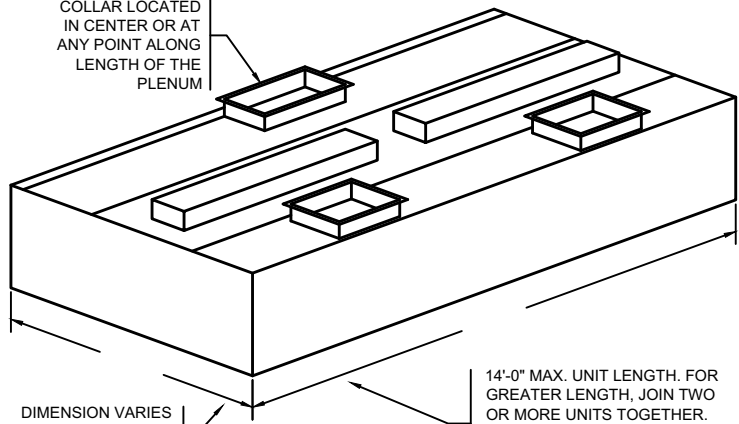

14'-0" MAX. UNIT LENGTH. FOR GREATER LENGTH, JOIN TWO OR MORE UNITS TOGETHER. ALLOW 6" MIN. OVERHANG AT EACH END. IF CHARBROILER IS AT END, OVERHANG 12"

DIMENSION VARIES WITH DEPTH OF THE EQUIPMENT AND REQUIRED OVERHANG

STANDARD LIGHT FIXTURES
 100 WATT INCANDESCENT
 RECESSED INCANDESCENT
 RECESSED FLUORESCENT
 (IF RECESSED FLUORESCENT SPECIFY SIZE)

CONSULT FACTORY FOR NON-STANDARD HEIGHTS
 22" MIN. FRONT OVERHANG
 6" MIN. SIDE OVERHANG
 (12" MIN. SIDE OVERHANG FOR CHARBROILER)

ITEM # _____
 EST. WEIGHT _____
 LENGTH _____
 WIDTH _____
 HEIGHT _____
 EXHAUST-CFM _____
 DUCT SIZE _____
 S.P. _____
 H.W. INLET SIZE _____
 DRAIN SIZE _____
 _____ GPM @ 40 PSI
 WATER TEMP 140°F - 180°F
 NOTE: 5 MIN. WASH CYCLE PER 24 HR PERIOD

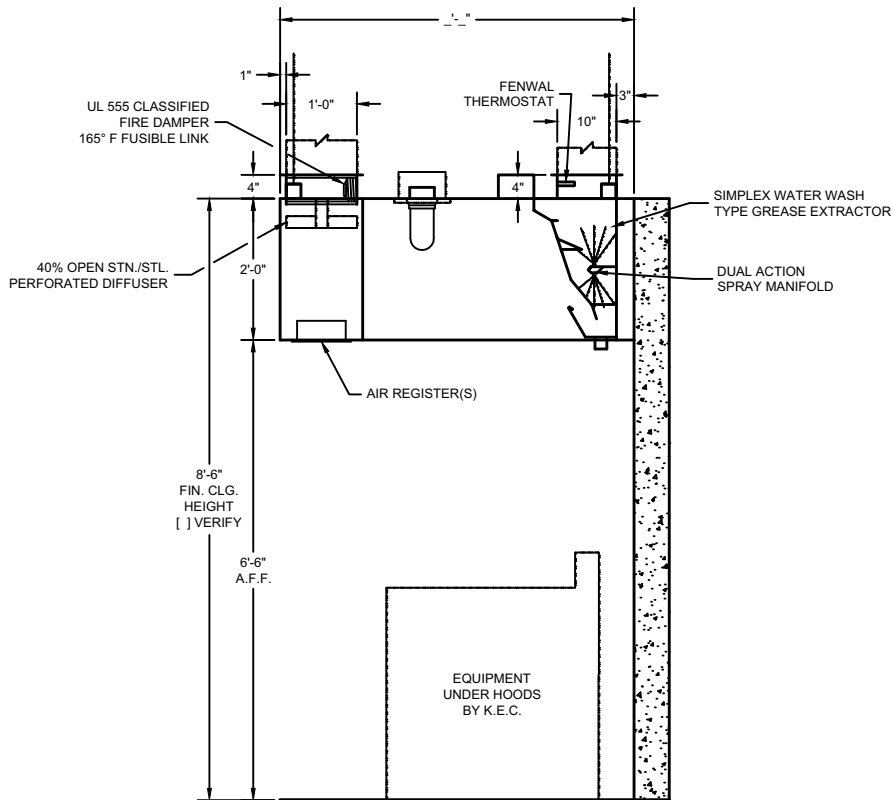

SECTION

DRAWINGS NOT TO SCALE

ENGINEERING DATA

Ventilator Length

Maximum ventilator length in a single section is 14'-0". For lengths greater than 14'-0", join two or more sections. Verify access conditions into building and kitchen space prior to length selection.

Ventilator Hanging Weight

Wt./ lineal ft.	Lbs.	105
-----------------	------	-----

NOTE: Refer to **CADDY AirSystems** Master Engineering Data Sheet in engineering data section for determining light, medium, and heavy duty cooking equipment, C.F.M. requirements (exhaust and supply), duct collar sizes and static pressure requirements.

Electrical Requirements

Provide 120 volt, single phase, 60 hertz, 15 amp (min.) 24 hour service to **CADDY AirSystems** CPE control panel (refer to CPE engineering cut sheet). Control panel to be fused separately. Light fixtures to be powered by a 120/1/60 circuit.

Mechanical Requirements

The volume of exhaust required is a function of the type of cooking equipment served by the ventilator, and the type and volume of product cooked. Refer to the **CADDY AirSystems** Master Engineering Data Chart to determine exhaust volume, duct collar sizes, static pressure drop, water consumption and ventilator drain sizes.



Model SHW-C-W

Waterwash Ventilator With Ceiling Supply Plenum

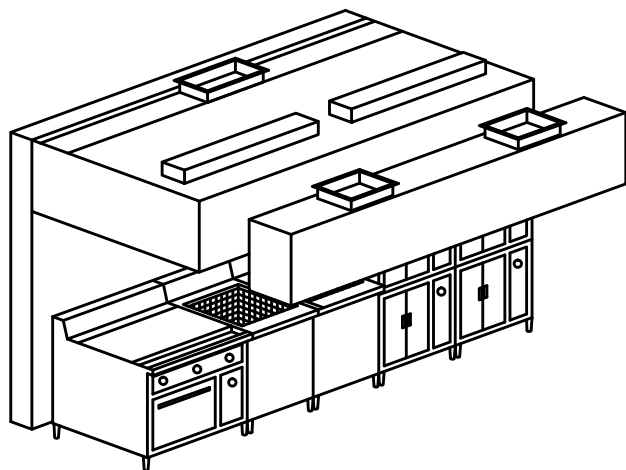

General Specifications

Furnish CADDY *AirSystems* Exhaust Hood Model **SHW-C-W-ASII** as shown on the plans and as described in the following specifications.

General

Exhaust hood shall be constructed of 18 gauge type 300 series stainless steel. All exposed surfaces to have a number # 4 finish. Construction to meet all requirements of NFPA 96 and NSF Standard No.2. To include necessary hanger brackets at front and rear for suspending from building overhead structure.

Description

The CADDY *AirSystems* Model "SHW" Ventilator is a water-wash type and is UL Listed under the standards set forth in UL 710 "Exhaust Hoods for Commercial Cooking Equipment". This ventilator is 95% grease extraction efficient when operated and maintained in accordance with design specifications. This high efficiency is accomplished by utilizing a high velocity centrifugal grease extractor, with the air inlet opening parallel to the cooking equipment it serves. Each ventilator shall have three full-length horizontal baffles for centrifugal grease extraction and shall be equipped with one full-length wash manifold with upper and lower brass spray nozzles for superior extraction. Ventilators shall operate at air quantities as illustrated on plans.

Accessibility and Inspection

Full length removable inspection doors shall be provided so that service can be performed on all interior components.

Automatic Washdown System

Ventilator to be equipped with one full length wash manifold with spray nozzles for automatic detergent injected wash using 140°F to 180°F hot water. Plumbing and electrical components for operation of the automatic wash system to be housed in the CADDY *AirSystems* Model "CPE" control panel.

Plumbing/Electrical

Ventilators to be factory pre-plumbed and pre-wired to a single connection point. Ventilators built in multiple sections to be furnished with unions and junction boxes for field connections by applicable trades.

Make-Up Air (Perimeter Down Discharge)

Up to 80% of the exhaust air may be supplied through this down discharge system. However, the air must be tempered to a minimum of 65°F to avoid discomfort to operations personnel.

Application

Wall mounted canopy style for use over all types of cooking equipment where integral make-up air is required.

Light Fixtures

All light fixtures shall be pre-wired to a single connection point. Ventilators built in multiple sections to be furnished with junction boxes for ease of field connection by the electrical trades. Light bulbs furnished and installed by the Kitchen Equipment Contractor.

Exhaust Fans

Exhaust fans are to be provided and installed by others in compliance with local codes. **Fans should be induced draft, squirrel cage design, equipped with backward inclined blades.**

Fire Protection

NFPA 96 and local codes require a fire extinguishing system for protection of the duct collar and plenum of all ventilators, as well as for the protection of various cooking appliances such as deep fat fryers, griddles, ranges, and broilers, which may be a source of ignition of grease. Consult factory and local fire officials for exact requirements. UL Listed fire protection systems may be pre-piped by Caddy at the time of manufacture, assuring concealment of piping and detectors.

Approvals

Ventilator shall be UL Listed, listed by NSF and be in accordance with all of the recommendations set forth by NFPA 96. All ventilators must meet all applicable codes.



MODEL:

SHW-C-W---

ADD THE OVERALL LENGTH (IN INCHES) OF THE VENTILATOR AFTER MODEL DESIGNATION

DAMPER TYPE
ND - NO DAMPER
FL - FUSIBLE LINK
T - THERMOSTAT

ADD THE OVERALL WIDTH (IN INCHES) OF THE VENTILATOR AFTER MODEL DESIGNATION

X
EXHAUST DUCT COLLAR LOCATED IN CENTER OR AT ANY POINT ALONG LENGTH OF THE PLENUM

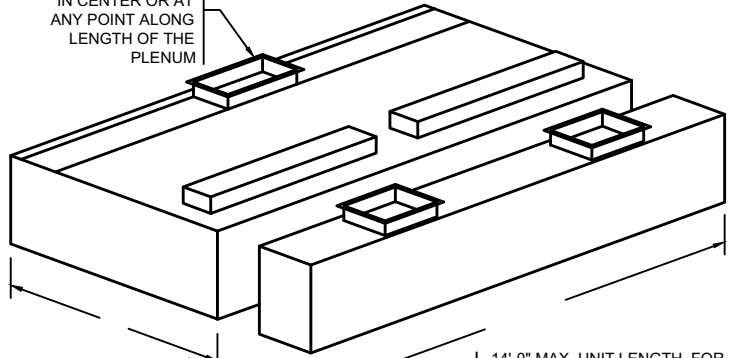

DIMENSION VARIES WITH DEPTH OF THE EQUIPMENT AND REQUIRED OVERHANG

14'-0" MAX. UNIT LENGTH. FOR GREATER LENGTH, JOIN TWO OR MORE UNITS TOGETHER. ALLOW 6" MIN. OVERHANG AT EACH END. IF CHARBROILER IS AT END, OVERHANG 12"

STANDARD LIGHT FIXTURES
 100 WATT INCANDESCENT
 RECESSED INCANDESCENT
 RECESSED FLUORESCENT
 (IF RECESSED FLUORESCENT SPECIFY SIZE)

CONSULT FACTORY FOR NON-STANDARD HEIGHTS
 22" MIN. FRONT OVERHANG
 6" MIN. SIDE OVERHANG
 (12" MIN. SIDE OVERHANG FOR CHARBROILER)

ITEM # _____
 EST. WEIGHT _____
 LENGTH _____
 WIDTH _____
 HEIGHT _____
 EXHAUST-CFM _____
 DUCT SIZE _____
 S.P. _____
 H.W. INLET SIZE _____
 DRAIN SIZE _____
 _____ GPM @ 40 PSI
 WATER TEMP 140°F - 180°F
 NOTE: 5 MIN. WASH CYCLE PER 24 HR PERIOD

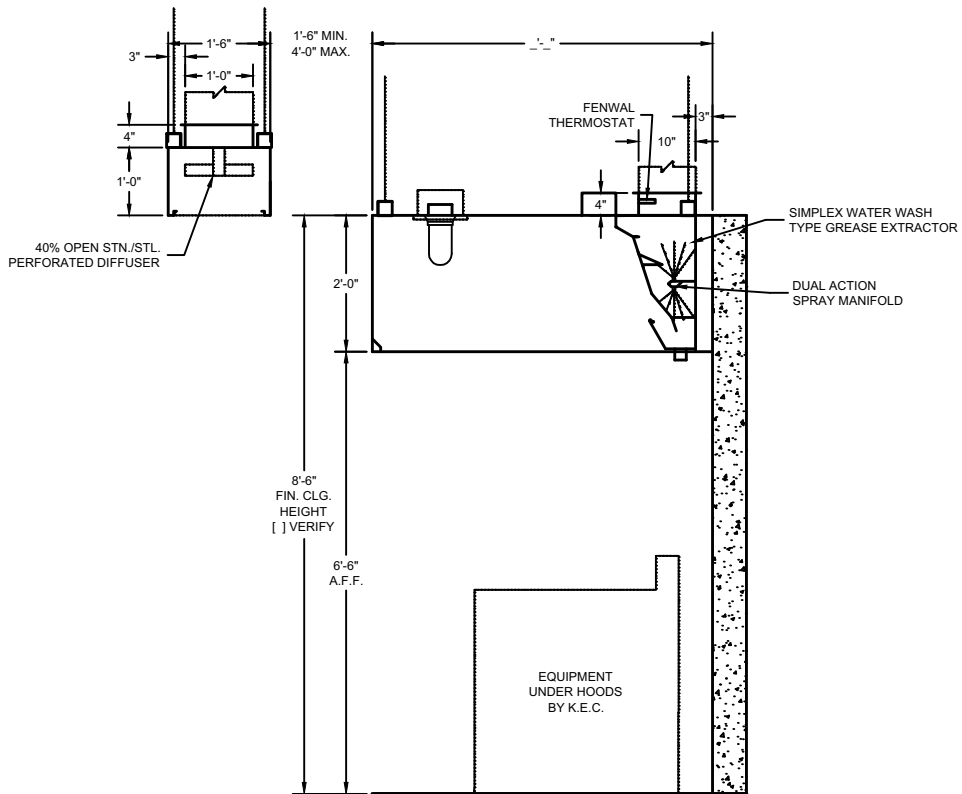

SECTION

DRAWINGS NOT TO SCALE

ENGINEERING DATA

Ventilator Length

Maximum ventilator length in a single section is 14'-0". For lengths greater than 14'-0", join two or more sections. Verify access conditions into building and kitchen space prior to length selection.

Ventilator Hanging Weight

Wt./ lineal ft.	Lbs.	105
-----------------	------	-----

NOTE: Refer to CADDY AirSystems

Master Engineering Data Sheet in engineering data section for determining light, medium, and heavy duty cooking equipment, C.F.M. requirements (exhaust and supply), duct collar sizes and static pressure requirements.

Electrical Requirements

Provide 120 volt, single phase, 60 hertz, 15 amp (min.) 24 hour service to **CADDY AirSystems** CPE control panel (refer to CPE engineering cut sheet). Control panel to be fused separately. Light fixtures to be powered by a 120/1/60 circuit.

Mechanical Requirements

The volume of exhaust required is a function of the type of cooking equipment served by the ventilator, and the type and volume of product cooked. Refer to the **CADDY AirSystems** Master Engineering Data Chart to determine exhaust volume, duct collar sizes, static pressure drop, water consumption and ventilator drain sizes.





CADDY CORPORATION

Food Service Equipment

Air Systems

Commercial Kitchen Exhaust Systems

Model SHW

Single Island Style

Model SHW-C-I Waterwash Ventilator

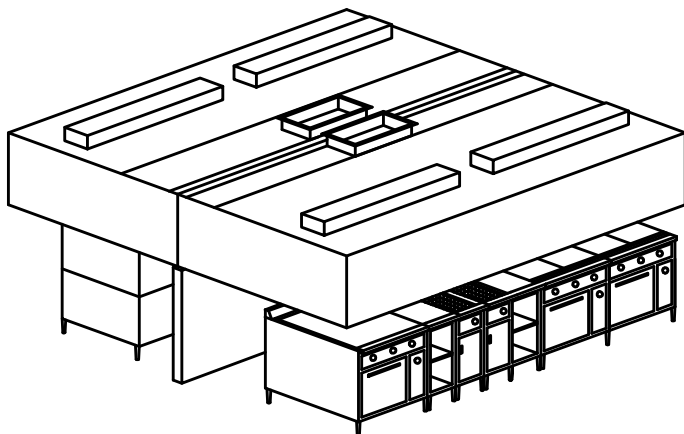

General Specifications

Furnish CADDY *AirSystems* Exhaust Hood Model **SHW-C-I** as shown on the plans and as described in the following specifications.

General

Exhaust hood shall be constructed of 18 gauge type 300 series stainless steel. All exposed surfaces to have a number # 4 finish. Construction to meet all requirements of NFPA 96 and NSF Standard No.2. To include necessary hanger brackets at front and rear for suspending from building overhead structure.

Description

The CADDY *AirSystems* Model "SHW" Ventilator is a water-wash type and is UL Listed under the standards set forth in UL 710 "Exhaust Hoods for Commercial Cooking Equipment". This ventilator is 95% grease extraction efficient when operated and maintained in accordance with design specifications. This high efficiency is accomplished by utilizing a high velocity centrifugal grease extractor, with the air inlet opening parallel to the cooking equipment it serves. Each ventilator shall have three full-length horizontal baffles for centrifugal grease extraction and shall be equipped with one full-length wash manifold with upper and lower brass spray nozzles for superior extraction. Ventilators shall operate at air quantities as illustrated on plans.

Accessibility and Inspection

Full length removable inspection doors shall be provided so that service can be performed on all interior components.

Automatic Washdown System

Ventilator to be equipped with one full length wash manifold with spray nozzles for automatic detergent injected wash using 140°F to 180°F hot water. Plumbing and electrical components for operation of the automatic wash system to be housed in the CADDY *AirSystems* Model "CPE" control panel.

Plumbing/Electrical

Ventilators to be factory pre-plumbed and pre-wired to a single connection point. Ventilators built in multiple sections to be furnished with unions and junction boxes for field connections by applicable trades.

Application

Island style cooking applications for use over all types of cooking equipment.

Light Fixtures

All light fixtures shall be pre-wired to a single connection point. Ventilators built in multiple sections to be furnished with junction boxes for ease of field connection by the electrical trades. Light bulbs furnished and installed by the Kitchen Equipment Contractor.

Exhaust Fans

Exhaust fans are to be provided and installed by others in compliance with local codes. **Fans should be induced draft, squirrel cage design, equipped with backward inclined blades.**

Fire Protection

NFPA 96 and local codes require a fire extinguishing system for protection of the duct collar and plenum of all ventilators, as well as for the protection of various cooking appliances such as deep fat fryers, griddles, ranges, and broilers, which may be a source of ignition of grease. Consult factory and local fire officials for exact requirements. UL Listed fire protection systems may be pre-piped by Caddy at the time of manufacture, assuring concealment of piping and detectors.

Approvals

Ventilator shall be UL Listed, listed by NSF and be in accordance with all of the recommendations set forth by NFPA 96. All ventilators must meet all applicable codes.



MODEL:

SHW-C-I---

ADD THE OVERALL LENGTH (IN INCHES) OF THE VENTILATOR AFTER MODEL DESIGNATION

DAMPER TYPE
ND - NO DAMPER
FL - FUSIBLE LINK
T - THERMOSTAT

ADD THE OVERALL WIDTH (IN INCHES) OF THE VENTILATOR AFTER MODEL DESIGNATION

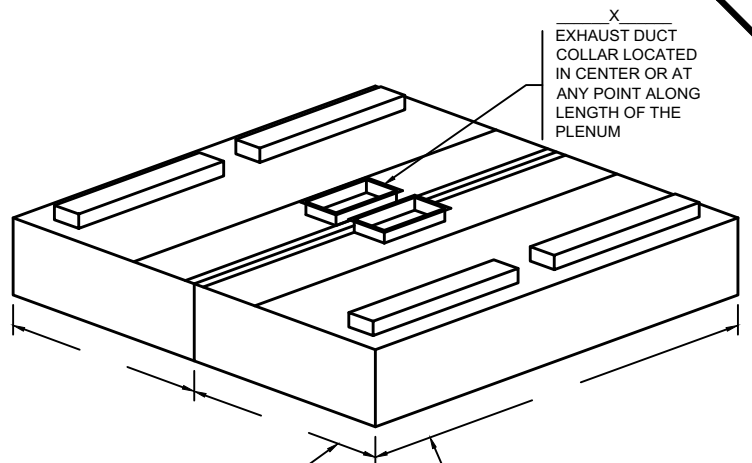

X
EXHAUST DUCT COLLAR LOCATED IN CENTER OR AT ANY POINT ALONG LENGTH OF THE PLENUM

DIMENSION VARIES WITH DEPTH OF THE EQUIPMENT AND REQUIRED OVERHANG

14'-0" MAX. UNIT LENGTH. FOR GREATER LENGTH, JOIN TWO OR MORE UNITS TOGETHER. ALLOW 6" MIN. OVERHANG AT EACH END. IF CHARBROILER IS AT END, OVERHANG 12"

STANDARD LIGHT FIXTURES
 100 WATT INCANDESCENT
 RECESSED INCANDESCENT
 RECESSED FLUORESCENT
 (IF RECESSED FLUORESCENT SPECIFY SIZE)

CONSULT FACTORY FOR NON-STANDARD HEIGHTS
 12" MIN. FRONT OVERHANG
 6" MIN. SIDE OVERHANG (12" MIN. SIDE OVERHANG FOR CHARBROILER)

ITEM # _____
 EST. WEIGHT _____
 LENGTH _____
 WIDTH _____
 HEIGHT _____
 EXHAUST-CFM _____
 DUCT SIZE _____
 S.P. _____
 H.W. INLET SIZE _____
 DRAIN SIZE _____
 _____ GPM @ 40 PSI
 WATER TEMP 140°F - 180°F
 NOTE: 5 MIN. WASH CYCLE PER 24 HR PERIOD

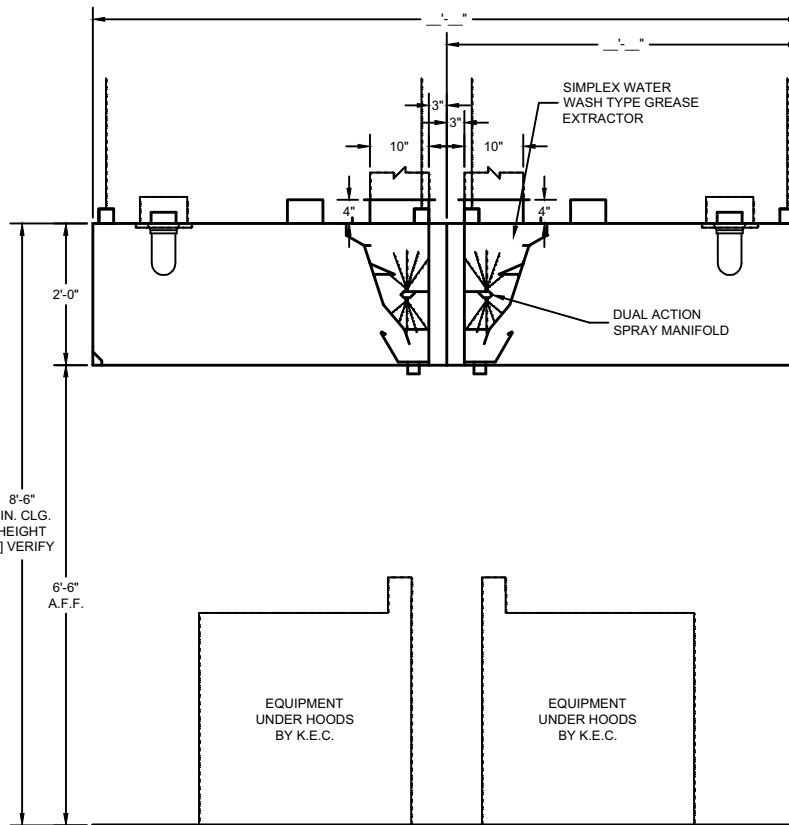

SIMPLEX WATER WASH TYPE GREASE EXTRACTOR

DUAL ACTION SPRAY MANIFOLD

8'-6" FIN. CLG. HEIGHT [] VERIFY
 6'-6" A.F.F.

EQUIPMENT UNDER HOODS BY K.E.C.

EQUIPMENT UNDER HOODS BY K.E.C.

SECTION

DRAWINGS NOT TO SCALE

ENGINEERING DATA

Ventilator Length

Maximum ventilator length in a single section is 14'-0". For lengths greater than 14'-0", join two or more sections. Verify access conditions into building and kitchen space prior to length selection.

Ventilator Hanging Weight

Wt./lineal ft.	Lbs.	90

NOTE: Refer to CADDY AirSystems

Master Engineering Data Sheet in engineering data section for determining light, medium, and heavy duty cooking equipment, C.F.M. requirements (exhaust and supply), duct collar sizes and static pressure requirements.

Electrical Requirements

Provide 120 volt, single phase, 60 hertz, 15 amp (min.) 24 hour service to **CADDY AirSystems** CPE control panel (refer to CPE engineering cut sheet). Control panel to be fused separately. Light fixtures to be powered by a 120/1/60 circuit.

Mechanical Requirements

The volume of exhaust required is a function of the type of cooking equipment served by the ventilator, and the type and volume of product cooked. Refer to the **CADDY AirSystems** Master Engineering Data Chart to determine exhaust volume, duct collar sizes, static pressure drop, water consumption and ventilator drain sizes.



Model SHW-C-I-PA Waterwash Ventilator

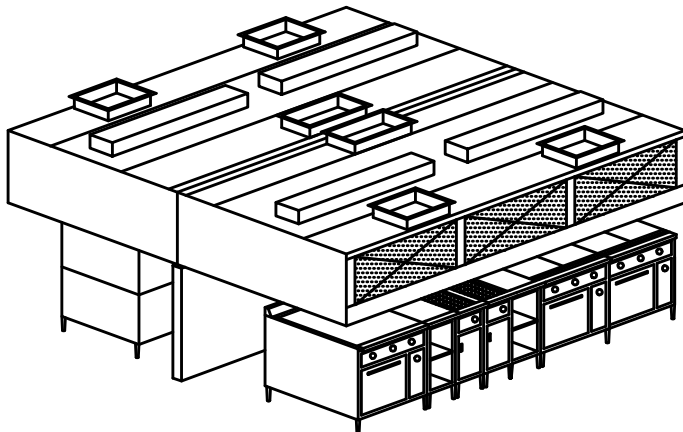

General Specifications

Furnish CADDY *AirSystems* Exhaust Hood Model **SHW-C-I-PA** as shown on the plans and as described in the following specifications.

General

Exhaust hood shall be constructed of 18 gauge type 300 series stainless steel. All exposed surfaces to have a number # 4 finish. Construction to meet all requirements of NFPA 96 and NSF Standard No.2. To include necessary hanger brackets at front and rear for suspending from building overhead structure.

Description

The CADDY *AirSystems* Model "SHW" Ventilator is a water-wash type and is UL Listed under the standards set forth in UL 710 "Exhaust Hoods for Commercial Cooking Equipment". This ventilator is 95% grease extraction efficient when operated and maintained in accordance with design specifications. This high efficiency is accomplished by utilizing a high velocity centrifugal grease extractor, with the air inlet opening parallel to the cooking equipment it serves. Each ventilator shall have three full-length horizontal baffles for centrifugal grease extraction and shall be equipped with one full-length wash manifold with upper and lower brass spray nozzles for superior extraction. Ventilators shall operate at air quantities as illustrated on plans.

Accessibility and Inspection

Full length removable inspection doors shall be provided so that service can be performed on all interior components.

Automatic Washdown System

Ventilator to be equipped with one full length wash manifold with spray nozzles for automatic detergent injected wash using 140°F to 180°F hot water. Plumbing and electrical components for operation of the automatic wash system to be housed in the CADDY *AirSystems* Model "CPE" control panel.

Plumbing/Electrical

Ventilators to be factory pre-plumbed and pre-wired to a single connection point. Ventilators built in multiple sections to be furnished with unions and junction boxes for field connections by applicable trades.

Make-Up Air (Front Face Discharge)

Ventilator shall have 40% open stainless steel perforated screens along front face for face discharge of tempered make-up air. This type of make-up air is the most common and advantageous method of bringing air into the kitchen via the kitchen exhaust ventilator. Typically supply volume is 80%, or more depending upon the desired air balance. Supply air temperature should range from 60°F - 65°F, but may be as low as 50°F, depending on air volume, distribution, internal heat load, and desired ambient room temperature.

Application

Island style cooking applications for use over all types of cooking equipment where integral MUA is required.

Light Fixtures

All light fixtures shall be pre-wired to a single connection point. Ventilators built in multiple sections to be furnished with junction boxes for ease of field connection by the electrical trades. Light bulbs furnished and installed by the Kitchen Equipment Contractor.

Exhaust Fans

Exhaust fans are to be provided and installed by others in compliance with local codes. **Fans should be induced draft, squirrel cage design, equipped with backward inclined blades.**

Fire Protection

NFPA 96 and local codes require a fire extinguishing system for protection of the duct collar and plenum of all ventilators, as well as for the protection of various cooking appliances such as deep fat fryers, griddles, ranges, and broilers, which may be a source of ignition of grease. Consult factory and local fire officials for exact requirements. UL Listed fire protection systems may be pre-piped by Caddy at the time of manufacture, assuring concealment of piping and detectors.

Approvals

Ventilator shall be UL Listed, listed by NSF and be in accordance with all of the recommendations set forth by NFPA 96. All ventilators must meet all applicable codes.



MODEL:

SHW-C-I-PA---

ADD THE OVERALL LENGTH (IN INCHES) OF THE VENTILATOR AFTER MODEL DESIGNATION

DAMPER TYPE
ND - NO DAMPER
FL - FUSIBLE LINK
T - THERMOSTAT

ADD THE OVERALL WIDTH (IN INCHES) OF THE VENTILATOR AFTER MODEL DESIGNATION

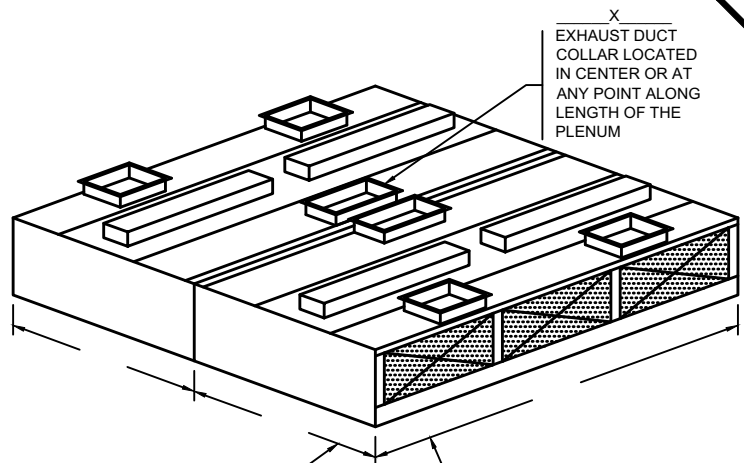

X
EXHAUST DUCT COLLAR LOCATED IN CENTER OR AT ANY POINT ALONG LENGTH OF THE PLENUM

DIMENSION VARIES WITH DEPTH OF THE EQUIPMENT AND REQUIRED OVERHANG

14'-0" MAX. UNIT LENGTH. FOR GREATER LENGTH, JOIN TWO OR MORE UNITS TOGETHER. ALLOW 6" MIN. OVERHANG AT EACH END. IF CHARBROILER IS AT END, OVERHANG 12"

STANDARD LIGHT FIXTURES
 100 WATT INCANDESCENT
 RECESSED INCANDESCENT
 RECESSED FLUORESCENT
 (IF RECESSED FLUORESCENT SPECIFY SIZE)

CONSULT FACTORY FOR NON-STANDARD HEIGHTS

12" MIN. FRONT OVERHANG

6" MIN. SIDE OVERHANG
 (12" MIN. SIDE OVERHANG FOR CHARBROILER)

- ITEM # _____
- EST. WEIGHT _____
- LENGTH _____
- WIDTH _____
- HEIGHT _____
- EXHAUST-CFM _____
- DUCT SIZE _____
- S.P. _____
- H.W. INLET SIZE _____
- DRAIN SIZE _____

___ GPM @ 40 PSI

WATER TEMP 140°F - 180°F

NOTE: 5 MIN. WASH CYCLE PER 24 HR PERIOD

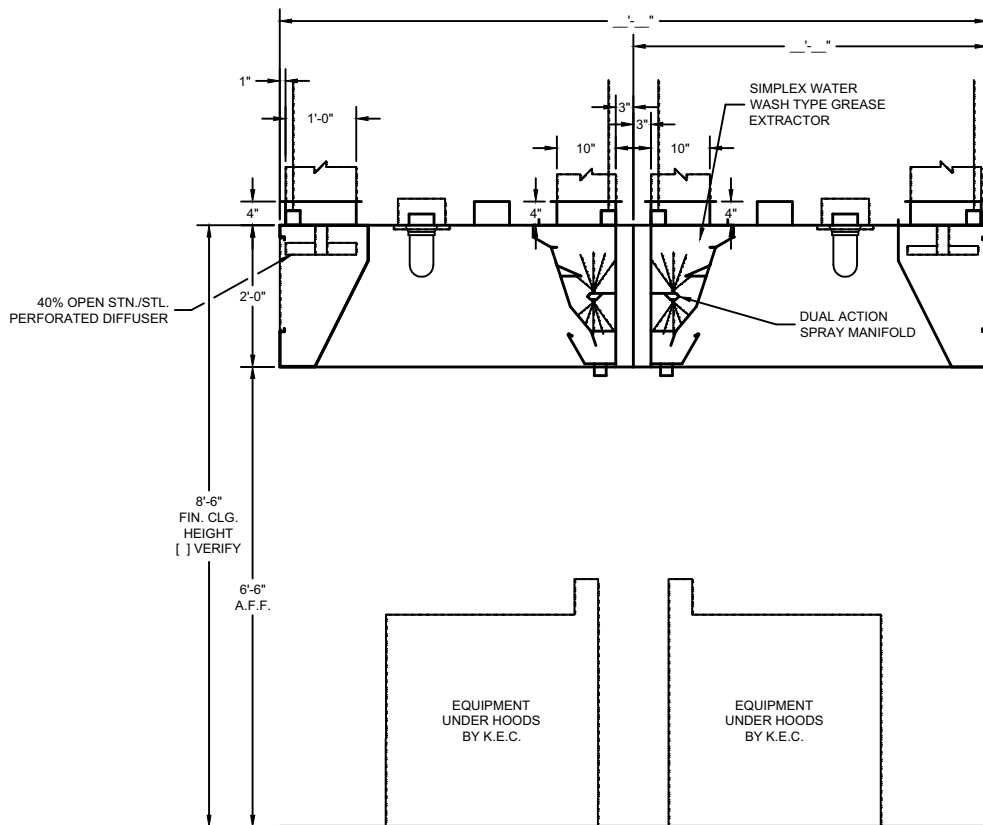

40% OPEN STN./STL. PERFORATED DIFFUSER

SIMPLEX WATER WASH TYPE GREASE EXTRACTOR

DUAL ACTION SPRAY MANIFOLD

8'-6" FIN. CLG. HEIGHT
 [] VERIFY

6'-6" A.F.F.

EQUIPMENT UNDER HOODS BY K.E.C.

EQUIPMENT UNDER HOODS BY K.E.C.

SECTION

DRAWINGS NOT TO SCALE

ENGINEERING DATA

Ventilator Length

Maximum ventilator length in a single section is 14'-0". For lengths greater than 14'-0", join two or more sections. Verify access conditions into building and kitchen space prior to length selection.

Ventilator Hanging Weight

Wt./lineal ft.	Lbs.	105
----------------	------	-----

NOTE: Refer to CADDY AirSystems

Master Engineering Data Sheet in engineering data section for determining light, medium, and heavy duty cooking equipment, C.F.M. requirements (exhaust and supply), duct collar sizes and static pressure requirements.

Electrical Requirements

Provide 120 volt, single phase, 60 hertz, 15 amp (min.) 24 hour service to **CADDY AirSystems** CPE control panel (refer to CPE engineering cut sheet). Control panel to be fused separately. Light fixtures to be powered by a 120/1/60 circuit.

Mechanical Requirements

The volume of exhaust required is a function of the type of cooking equipment served by the ventilator, and the type and volume of product cooked. Refer to the **CADDY AirSystems** Master Engineering Data Chart to determine exhaust volume, duct collar sizes, static pressure drop, water consumption and ventilator drain sizes.



Model SHW-C-I-ASI Waterwash Ventilator

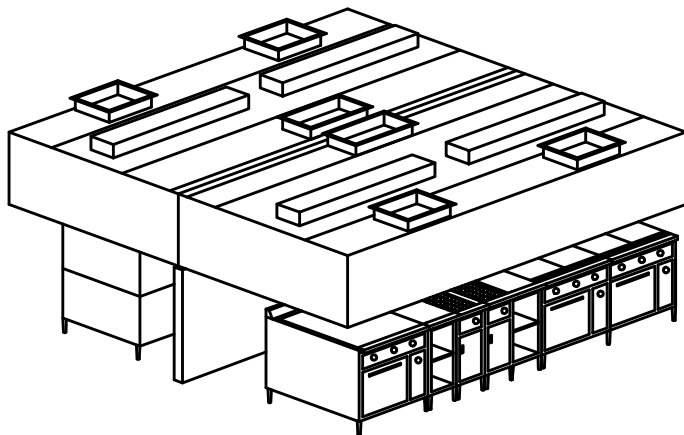

General Specifications

Furnish CADDY *AirSystems* Exhaust Hood Model **SHW-C-I-ASI** as shown on the plans and as described in the following specifications.

General

Exhaust hood shall be constructed of 18 gauge type 300 series stainless steel. All exposed surfaces to have a number # 4 finish. Construction to meet all requirements of NFPA 96 and NSF Standard No.2. To include necessary hanger brackets at front and rear for suspending from building overhead structure.

Description

The CADDY *AirSystems* Model "SHW" Ventilator is a water-wash type and is UL Listed under the standards set forth in UL 710 "Exhaust Hoods for Commercial Cooking Equipment". This ventilator is 95% grease extraction efficient when operated and maintained in accordance with design specifications. This high efficiency is accomplished by utilizing a high velocity centrifugal grease extractor, with the air inlet opening parallel to the cooking equipment it serves. Each ventilator shall have three full-length horizontal baffles for centrifugal grease extraction and shall be equipped with one full-length wash manifold with upper and lower brass spray nozzles for superior extraction. Ventilators shall operate at air quantities as illustrated on plans.

Accessibility and Inspection

Full length removable inspection doors shall be provided so that service can be performed on all interior components.

Automatic Washdown System

Ventilator to be equipped with one full length wash manifold with spray nozzles for automatic detergent injected wash using 140°F to 180°F hot water. Plumbing and electrical components for operation of the automatic wash system to be housed in the CADDY *AirSystems* Model "CPE" control panel.

Plumbing/Electrical

Ventilators to be factory pre-plumbed and pre-wired to a single connection point. Ventilators built in multiple sections to be furnished with unions and junction boxes for field connections by applicable trades.

Make-Up Air (Internal Discharge)

Ventilator shall have a fully insulated supply plenum, with duct collar/fire damper assemblies, and air registers internally mounted for discharging untempered make-up air directly into canopy of ventilator. The amount of make-up air supplied through this design is directly related to the type of cooking equipment located beneath the hood. The percentage of supply air distributed will vary as a function of the thermal currents generated by each individual appliance. When specifying this style, consult factory for specific supply volumes. This air may be untempered in most areas, depending upon climatic conditions and the type of cooking equipment. If the winter design temperature is below 10 degrees F, consult factory for air supply volumes and design considerations.

Application

Island style cooking applications for use over all types of cooking equipment where integral make-up air is required.

Light Fixtures

All light fixtures shall be pre-wired to a single connection point. Ventilators built in multiple sections to be furnished with junction boxes for ease of field connection by the electrical trades. Light bulbs furnished and installed by the Kitchen Equipment Contractor.

Exhaust Fans

Exhaust fans are to be provided and installed by others in compliance with local codes. **Fans should be induced draft, squirrel cage design, equipped with backward inclined blades.**

Fire Protection

NFPA 96 and local codes require a fire extinguishing system for protection of the duct collar and plenum of all ventilators, as well as for the protection of various cooking appliances such as deep fat fryers, griddles, ranges, and broilers, which may be a source of ignition of grease. Consult factory and local fire officials for exact requirements. UL Listed fire protection systems may be pre-piped by Caddy at the time of manufacture, assuring concealment of piping and detectors.

Approvals

Ventilator shall be UL Listed, listed by NSF and be in accordance with all of the recommendations set forth by NFPA 96. All ventilators must meet all applicable codes.



MODEL:

SHW-C-I-ASI---

ADD THE OVERALL LENGTH (IN INCHES) OF THE VENTILATOR AFTER MODEL DESIGNATION

DAMPER TYPE
ND - NO DAMPER
FL - FUSIBLE LINK
T - THERMOSTAT

ADD THE OVERALL WIDTH (IN INCHES) OF THE VENTILATOR AFTER MODEL DESIGNATION

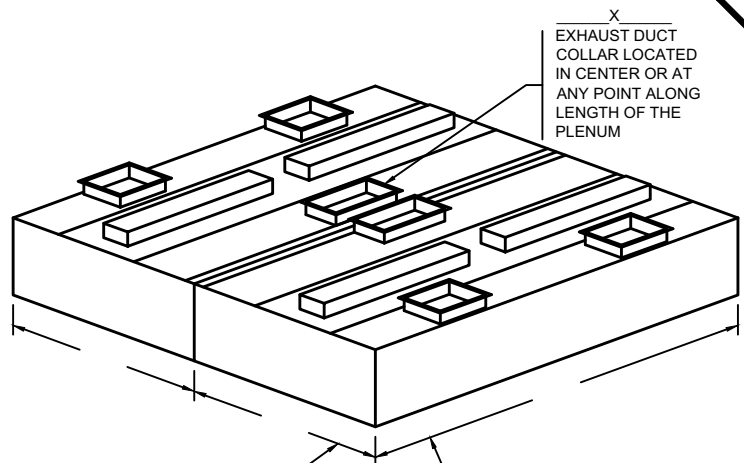

X
EXHAUST DUCT COLLAR LOCATED IN CENTER OR AT ANY POINT ALONG LENGTH OF THE PLENUM

DIMENSION VARIES WITH DEPTH OF THE EQUIPMENT AND REQUIRED OVERHANG

14'-0" MAX. UNIT LENGTH. FOR GREATER LENGTH, JOIN TWO OR MORE UNITS TOGETHER. ALLOW 6" MIN. OVERHANG AT EACH END. IF CHARBROILER IS AT END, OVERHANG 12"

STANDARD LIGHT FIXTURES
 100 WATT INCANDESCENT
 RECESSED INCANDESCENT
 RECESSED FLUORESCENT
 (IF RECESSED FLUORESCENT SPECIFY SIZE)

CONSULT FACTORY FOR NON-STANDARD HEIGHTS
 22" MIN. FRONT OVERHANG
 6" MIN. SIDE OVERHANG
 (12" MIN. SIDE OVERHANG FOR CHARBROILER)

ITEM # _____
 EST. WEIGHT _____
 LENGTH _____
 WIDTH _____
 HEIGHT _____
 EXHAUST-CFM _____
 DUCT SIZE _____
 S.P. _____
 H.W. INLET SIZE _____
 DRAIN SIZE _____
 _____ GPM @ 40 PSI
 WATER TEMP 140°F - 180°F
 NOTE: 5 MIN. WASH CYCLE PER 24 HR PERIOD

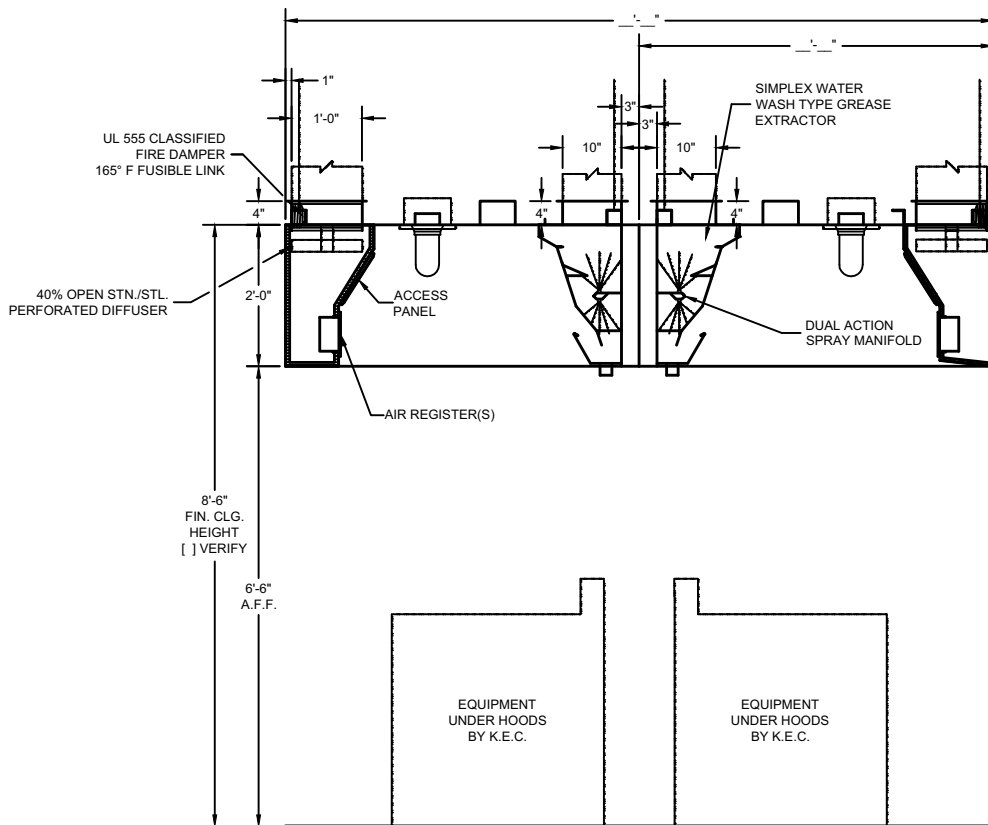

UL 555 CLASSIFIED FIRE DAMPER
165° F FUSIBLE LINK

40% OPEN STN./STL. PERFORATED DIFFUSER

ACCESS PANEL

AIR REGISTER(S)

SIMPLEX WATER WASH TYPE GREASE EXTRACTOR

DUAL ACTION SPRAY MANIFOLD

8'-6" FIN. CLG. HEIGHT [] VERIFY

6'-6" A.F.F.

EQUIPMENT UNDER HOODS BY K.E.C.

EQUIPMENT UNDER HOODS BY K.E.C.

SECTION

DRAWINGS NOT TO SCALE

ENGINEERING DATA

Ventilator Length

Maximum ventilator length in a single section is 14'-0". For lengths greater than 14'-0", join two or more sections. Verify access conditions into building and kitchen space prior to length selection.

Ventilator Hanging Weight

Wt./ lineal ft.	Lbs.	105
-----------------	------	-----

NOTE: Refer to CADDY AirSystems

Master Engineering Data Sheet in engineering data section for determining light, medium, and heavy duty cooking equipment, C.F.M. requirements (exhaust and supply), duct collar sizes and static pressure requirements.

Electrical Requirements

Provide 120 volt, single phase, 60 hertz, 15 amp (min.) 24 hour service to CADDY AirSystems CPE control panel (refer to CPE engineering cut sheet). Control panel to be fused separately. Light fixtures to be powered by a 120/1/60 circuit.

Mechanical Requirements

The volume of exhaust required is a function of the type of cooking equipment served by the ventilator, and the type and volume of product cooked. Refer to the CADDY AirSystems Master Engineering Data Chart to determine exhaust volume, duct collar sizes, static pressure drop, water consumption and ventilator drain sizes.



Model SHW-C-I-AA Waterwash Ventilator

ITEM NO:

PROJECT:

LOCATION:

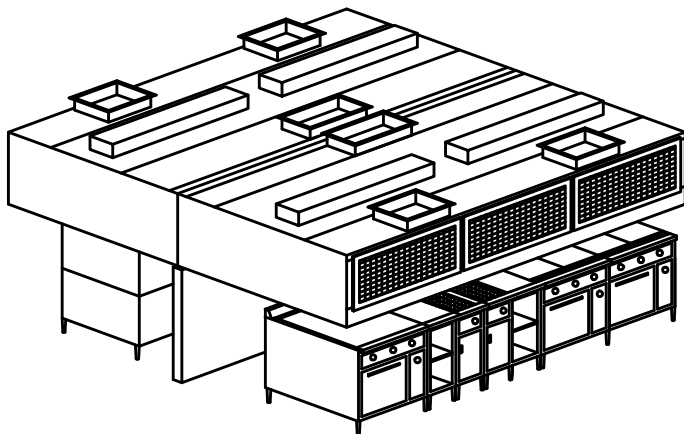

General Specifications

Furnish CADDY *AirSystems* Exhaust Hood Model **SHW-C-I-AA** as shown on the plans and as described in the following specifications.

General

Exhaust hood shall be constructed of 18 gauge type 300 series stainless steel. All exposed surfaces to have a number # 4 finish. Construction to meet all requirements of NFPA 96 and NSF Standard No.2. To include necessary hanger brackets at front and rear for suspending from building overhead structure.

Description

The CADDY *AirSystems* Model "SHW" Ventilator is a water-wash type and is UL Listed under the standards set forth in UL 710 "Exhaust Hoods for Commercial Cooking Equipment". This ventilator is 95% grease extraction efficient when operated and maintained in accordance with design specifications. This high efficiency is accomplished by utilizing a high velocity centrifugal grease extractor, with the air inlet opening parallel to the cooking equipment it serves. Each ventilator shall have three full-length horizontal baffles for centrifugal grease extraction and shall be equipped with one full-length wash manifold with upper and lower brass spray nozzles for superior extraction. Ventilators shall operate at air quantities as illustrated on plans.

Accessibility and Inspection

Full length removable inspection doors shall be provided so that service can be performed on all interior components.

Automatic Washdown System

Ventilator to be equipped with one full length wash manifold with spray nozzles for automatic detergent injected wash using 140°F to 180°F hot water. Plumbing and electrical components for operation of the automatic wash system to be housed in the CADDY *AirSystems* Model "CPE" control panel.

Plumbing/Electrical

Ventilators to be factory pre-plumbed and pre-wired to a single connection point. Ventilators built in multiple sections to be furnished with unions and junction boxes for field connections by applicable trades.

Make-Up Air (Front Face Register Discharge)

Ventilator shall have air registers along front face for discharge of tempered make-up air. Supply volume is 80%, or designed to the desired air balance.

Application

Island style cooking applications for use over all types of cooking equipment where integral make-up air is required.

Light Fixtures

All light fixtures shall be pre-wired to a single connection point. Ventilators built in multiple sections to be furnished with junction boxes for ease of field connection by the electrical trades. Light bulbs furnished and installed by the Kitchen Equipment Contractor.

Exhaust Fans

Exhaust fans are to be provided and installed by others in compliance with local codes. **Fans should be induced draft, squirrel cage design, equipped with backward inclined blades.**

Fire Protection

NFPA 96 and local codes require a fire extinguishing system for protection of the duct collar and plenum of all ventilators, as well as for the protection of various cooking appliances such as deep fat fryers, griddles, ranges, and broilers, which may be a source of ignition of grease. Consult factory and local fire officials for exact requirements. UL Listed fire protection systems may be pre-piped by Caddy at the time of manufacture, assuring concealment of piping and detectors.

Approvals

Ventilator shall be UL Listed, listed by NSF and be in accordance with all of the recommendations set forth by NFPA 96. All ventilators must meet all applicable codes.

 **CADDY CORPORATION**
509 Sharptown Road P.O. Box 345
Bridgeport, NJ 08014-0345
Tel: 856-467-4222 Fax: 856-467-5511
internet: www.caddycorp.com



MODEL:

SHW-C-I-AA---

ADD THE OVERALL LENGTH (IN INCHES) OF THE VENTILATOR AFTER MODEL DESIGNATION

DAMPER TYPE
ND - NO DAMPER
FL - FUSIBLE LINK
T - THERMOSTAT

ADD THE OVERALL WIDTH (IN INCHES) OF THE VENTILATOR AFTER MODEL DESIGNATION

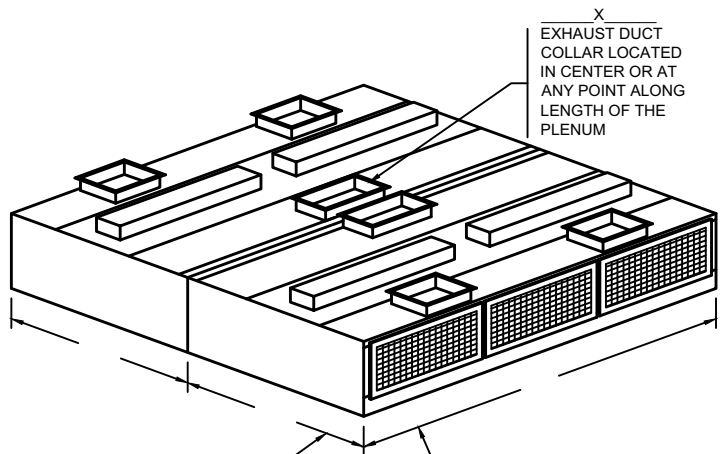

X
EXHAUST DUCT COLLAR LOCATED IN CENTER OR AT ANY POINT ALONG LENGTH OF THE PLENUM

DIMENSION VARIES WITH DEPTH OF THE EQUIPMENT AND REQUIRED OVERHANG

14'-0" MAX. UNIT LENGTH. FOR GREATER LENGTH, JOIN TWO OR MORE UNITS TOGETHER. ALLOW 6" MIN. OVERHANG AT EACH END. IF CHARBROILER IS AT END, OVERHANG 12"

STANDARD LIGHT FIXTURES
 100 WATT INCANDESCENT
 RECESSED INCANDESCENT
 RECESSED FLUORESCENT
 (IF RECESSED FLUORESCENT SPECIFY SIZE)

CONSULT FACTORY FOR NON-STANDARD HEIGHTS
 12" MIN. FRONT OVERHANG
 6" MIN. SIDE OVERHANG
 (12" MIN. SIDE OVERHANG FOR CHARBROILER)

ITEM # _____
 EST. WEIGHT _____
 LENGTH _____
 WIDTH _____
 HEIGHT _____
 EXHAUST-CFM _____
 DUCT SIZE _____
 S.P. _____
 H.W. INLET SIZE _____
 DRAIN SIZE _____
 _____ GPM @ 40 PSI
 WATER TEMP 140°F - 180°F
 NOTE: 5 MIN. WASH CYCLE PER 24 HR PERIOD

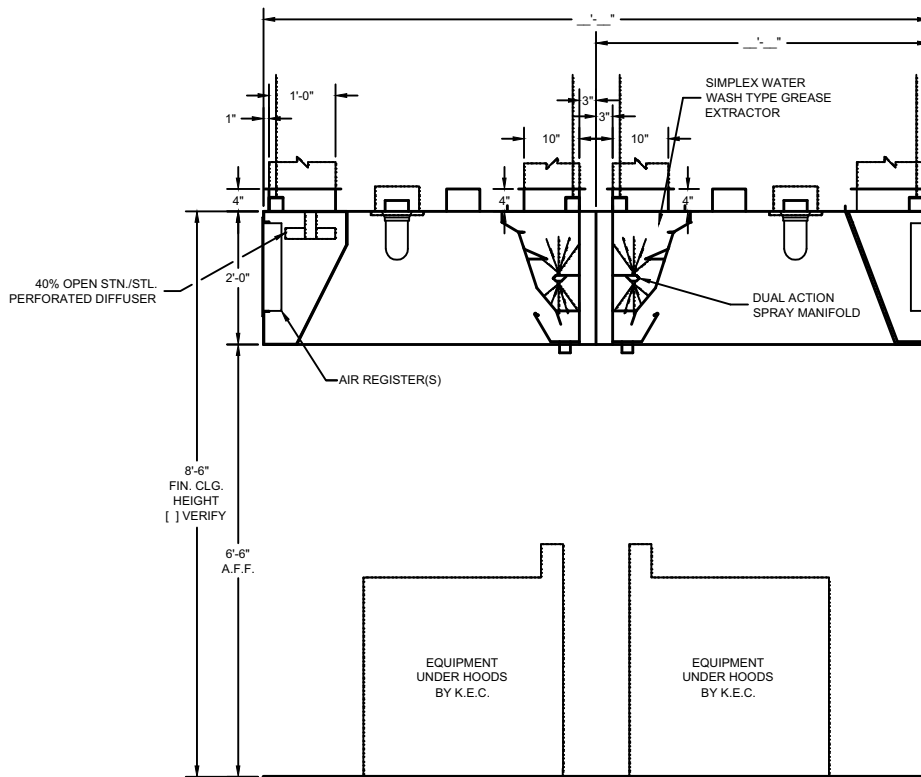

SECTION

DRAWINGS NOT TO SCALE

ENGINEERING DATA

Ventilator Length

Maximum ventilator length in a single section is 14'-0". For lengths greater than 14'-0", join two or more sections. Verify access conditions into building and kitchen space prior to length selection.

Ventilator Hanging Weight

Wt./ lineal ft.	Lbs.	105
-----------------	------	-----

NOTE: Refer to CADDY AirSystems

Master Engineering Data Sheet in engineering data section for determining light, medium, and heavy duty cooking equipment, C.F.M. requirements (exhaust and supply), duct collar sizes and static pressure requirements.

Electrical Requirements

Provide 120 volt, single phase, 60 hertz, 15 amp (min.) 24 hour service to CADDY AirSystems CPE control panel (refer to CPE engineering cut sheet). Control panel to be fused separately. Light fixtures to be powered by a 120/1/60 circuit.

Mechanical Requirements

The volume of exhaust required is a function of the type of cooking equipment served by the ventilator, and the type and volume of product cooked. Refer to the CADDY AirSystems Master Engineering Data Chart to determine exhaust volume, duct collar sizes, static pressure drop, water consumption and ventilator drain sizes.



Model SHW-C-I-ASII Waterwash Ventilator

ITEM NO:

PROJECT:

LOCATION:

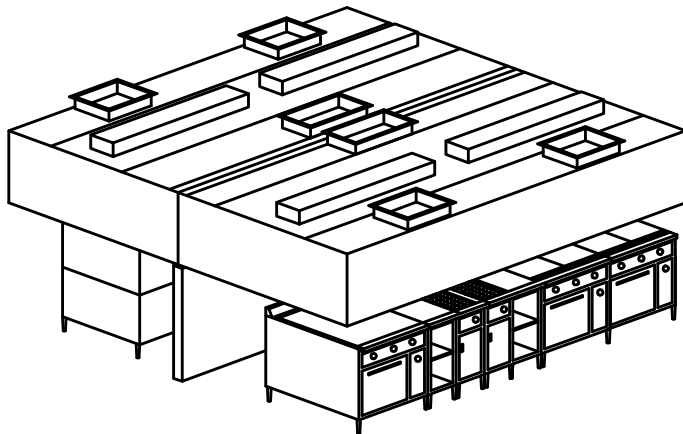

General Specifications

Furnish CADDY *AirSystems* Exhaust Hood Model **SHW-C-I-ASII** as shown on the plans and as described in the following specifications.

General

Exhaust hood shall be constructed of 18 gauge type 300 series stainless steel with all exposed surfaces a number 4 finish. Construction to meet all requirements of NFPA 96 and NSF Standard No.2. To include necessary hanger brackets at front and rear for suspending from building overhead structure.

Description

The CADDY *AirSystems* Model "SHW" Ventilator is a water-wash ventilator that is UL Listed under the standards set forth in UL 710 "Exhaust Hoods for Commercial Cooking Equipment". Each ventilator shall be a high velocity centrifugal grease extractor, with the air inlet opening parallel to the cooking equipment it serves. Each ventilator shall have three full-length horizontal baffles for centrifugal grease extraction. Each ventilator shall be equipped with one full-length wash manifold with upper and lower brass spray nozzles for superior extraction chamber cleaning action. Each ventilator shall have a grease extraction efficiency of 95% when operated within design parameters. This efficiency shall be achieved without the use of filters, cartridges, or constant running water. Ventilators shall operate at air quantities as illustrated on plans.

Accessibility and Inspection

Full length removable inspection doors shall be provided so that service can be performed on all interior components.

Automatic Washdown System

Ventilator to be equipped with one full length wash manifold with spray nozzles for automatic detergent injected wash using 140°F to 180°F hot water. Plumbing and electrical components for operation of the automatic wash system to be housed in the CADDY *AirSystems* Model "CPE" control panel.

Plumbing/Electrical

Ventilators to be factory pre-plumbed and pre-wired to a single connection point. Ventilators built in multiple sections to be furnished with unions and junction boxes for field connections by applicable trades.

Make-Up Air (Perimeter Down Discharge)

Ventilator shall have air registers along perimeter for down discharge of tempered make-up. Supply volume is 80% or designed to the desired air balance.

Application

Island style cooking applications for use over all types of cooking equipment where integral make-up air is required.

Light Fixtures

All light fixtures shall be pre-wired to a single connection point. Ventilators built in multiple sections to be furnished with junction boxes for ease of field connection by the electrical trades. Light bulbs furnished and installed by the Kitchen Equipment Contractor.

Exhaust Fans

Exhaust fans are to be provided and installed by others in compliance with local codes. **Fans should be induced draft, squirrel cage design, equipped with backward inclined blades.**

Fire Protection

NFPA 96 and local codes require a fire extinguishing system for protection of the duct collar and plenum of all ventilators, as well as for the protection of various cooking appliances such as deep fat fryers, griddles, ranges, and broilers, which may be a source of ignition of grease. Consult factory and local fire officials for exact requirements. UL Listed fire protection systems may be pre-piped by Caddy at the time of manufacture, assuring concealment of piping and detectors.

Approvals

Ventilator shall be UL Listed, listed by NSF and be in accordance with all of the recommendations set forth by NFPA 96. All ventilators must meet all applicable codes.



MODEL:

SHW-C-I-ASII---

ADD THE OVERALL LENGTH (IN INCHES) OF THE VENTILATOR AFTER MODEL DESIGNATION

DAMPER TYPE
ND - NO DAMPER
FL - FUSIBLE LINK
T - THERMOSTAT

ADD THE OVERALL WIDTH (IN INCHES) OF THE VENTILATOR AFTER MODEL DESIGNATION

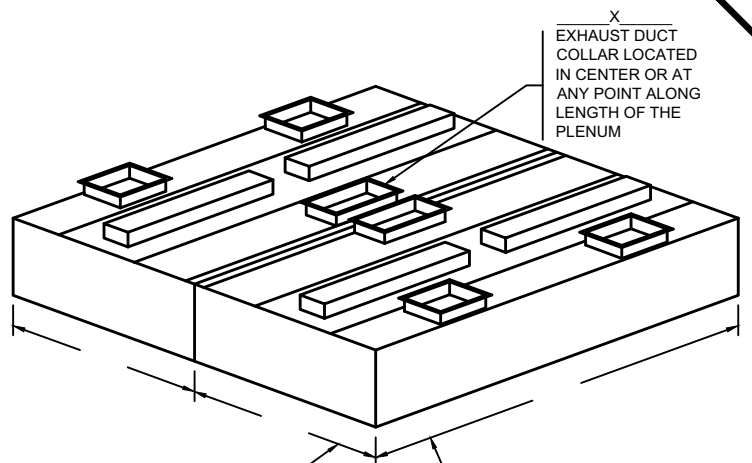

X
EXHAUST DUCT COLLAR LOCATED IN CENTER OR AT ANY POINT ALONG LENGTH OF THE PLENUM

DIMENSION VARIES WITH DEPTH OF THE EQUIPMENT AND REQUIRED OVERHANG

14'-0" MAX. UNIT LENGTH. FOR GREATER LENGTH, JOIN TWO OR MORE UNITS TOGETHER. ALLOW 6" MIN. OVERHANG AT EACH END. IF CHARBROILER IS AT END, OVERHANG 12"

STANDARD LIGHT FIXTURES
 100 WATT INCANDESCENT
 RECESSED INCANDESCENT
 RECESSED FLUORESCENT
 (IF RECESSED FLUORESCENT SPECIFY SIZE)

CONSULT FACTORY FOR NON-STANDARD HEIGHTS
 22" MIN. FRONT OVERHANG
 6" MIN. SIDE OVERHANG (12" MIN. SIDE OVERHANG FOR CHARBROILER)

ITEM # _____
 EST. WEIGHT _____
 LENGTH _____
 WIDTH _____
 HEIGHT _____
 EXHAUST-CFM _____
 DUCT SIZE _____
 S.P. _____
 H.W. INLET SIZE _____
 DRAIN SIZE _____
 _____ GPM @ 40 PSI
 WATER TEMP 140°F - 180°F
 NOTE: 5 MIN. WASH CYCLE PER 24 HR PERIOD

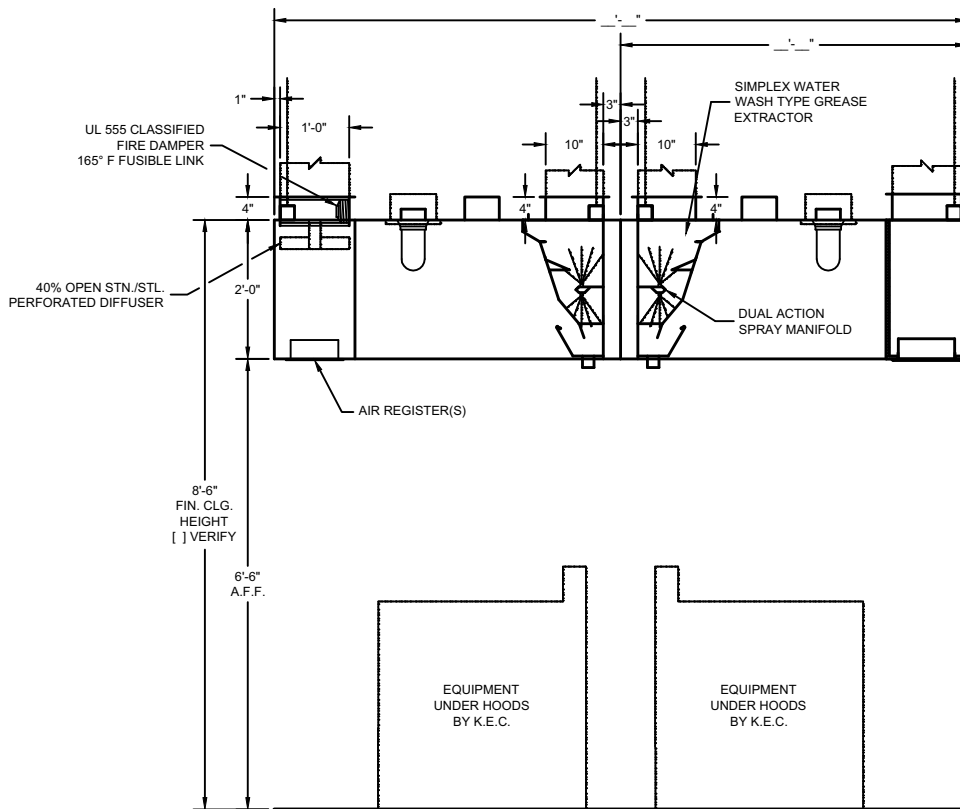

SECTION

DRAWINGS NOT TO SCALE

ENGINEERING DATA

Ventilator Length

Maximum ventilator length in a single section is 14'-0". For lengths greater than 14'-0", join two or more sections. Verify access conditions into building and kitchen space prior to length selection.

Ventilator Hanging Weight

Wt./ lineal ft.	Lbs.	105
-----------------	------	-----

NOTE: Refer to **CADDY AirSystems** Master Engineering Data Sheet in engineering data section for determining light, medium, and heavy duty cooking equipment, C.F.M. requirements (exhaust and supply), duct collar sizes and static pressure requirements.

Electrical Requirements

Provide 120 volt, single phase, 60 hertz, 15 amp (min.) 24 hour service to **CADDY AirSystems** CPE control panel (refer to CPE engineering cut sheet). Control panel to be fused separately. Light fixtures to be powered by a 120/1/60 circuit.

Mechanical Requirements

The volume of exhaust required is a function of the type of cooking equipment served by the ventilator, and the type and volume of product cooked. Refer to the **CADDY AirSystems** Master Engineering Data Chart to determine exhaust volume, duct collar sizes, static pressure drop, water consumption and ventilator drain sizes.



Model SHW-C-I

Waterwash Ventilator With Ceiling Supply Plenum

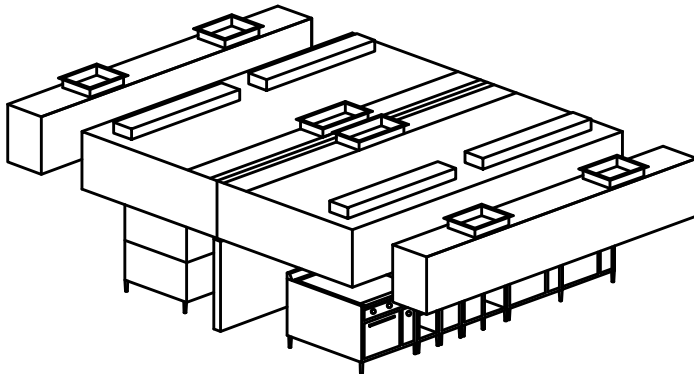

General Specifications

Furnish CADDY *AirSystems* Exhaust Hood Model **SHW-C-I-ASII** as shown on the plans and as described in the following specifications.

General

Exhaust hood shall be constructed of 18 gauge type 300 series stainless steel with all exposed surfaces a number 4 finish. Construction to meet all requirements of NFPA 96 and NSF Standard No.2. To include necessary hanger brackets at front and rear for suspending from building overhead structure.

Description

The CADDY *AirSystems* Model "SHW" Ventilator is a water-wash ventilator that is UL Listed under the standards set forth in UL 710 "Exhaust Hoods for Commercial Cooking Equipment". Each ventilator shall be a high velocity centrifugal grease extractor, with the air inlet opening parallel to the cooking equipment it serves. Each ventilator shall have three full-length horizontal baffles for centrifugal grease extraction. Each ventilator shall be equipped with one full-length wash manifold with upper and lower brass spray nozzles for superior extraction chamber cleaning action. Each ventilator shall have a grease extraction efficiency of 95% when operated within design parameters. This efficiency shall be achieved without the use of filters, cartridges, or constant running water. Ventilators shall operate at air quantities as illustrated on plans.

Accessibility and Inspection

Full length removable inspection doors shall be provided so that service can be performed on all interior components.

Automatic Washdown System

Ventilator to be equipped with one full length wash manifold with spray nozzles for automatic detergent injected wash using 140°F to 180°F hot water. Plumbing and electrical components for operation of the automatic wash system to be housed in the CADDY *AirSystems* Model "CPE" control panel.

Plumbing/Electrical

Ventilators to be factory pre-plumbed and pre-wired to a single connection point. Ventilators built in multiple sections to be furnished with unions and junction boxes for filed connections by applicable trades.

Make-Up Air (Perimeter Down Discharge)

Ventilator shall have air registers along perimeter for down discharge of tempered make-up. Supply volume is 80% or designed to the desired air balance.

Application

Island style cooking applications for use over all types of cooking equipment where integral make-up air is required.

Light Fixtures

All light fixtures shall be pre-wired to a single connection point. Ventilators built in multiple sections to be furnished with junction boxes for ease of field connection by the electrical trades. Light bulbs furnished and installed by the Kitchen Equipment Contractor.

Exhaust Fans

Exhaust fans are to be provided and installed by others in compliance with local codes. **Fans should be induced draft, squirrel cage design, equipped with backward inclined blades.**

Fire Protection

NFPA 96 and local codes require a fire extinguishing system for protection of the duct collar and plenum of all ventilators, as well as for the protection of various cooking appliances such as deep fat fryers, griddles, ranges, and broilers, which may be a source of ignition of grease. Consult factory and local fire officials for exact requirements. UL Listed fire protection systems may be pre-piped by Caddy at the time of manufacture, assuring concealment of piping and detectors.

Approvals

Ventilator shall be UL Listed, listed by NSF and be in accordance with all of the recommendations set forth by NFPA 96. All ventilators must meet all applicable codes.



MODEL:

SHW-C-I---

ADD THE OVERALL LENGTH (IN INCHES) OF THE VENTILATOR AFTER MODEL DESIGNATION

DAMPER TYPE
ND - NO DAMPER
FL - FUSIBLE LINK
T - THERMOSTAT

ADD THE OVERALL WIDTH (IN INCHES) OF THE VENTILATOR AFTER MODEL DESIGNATION

X
EXHAUST DUCT COLLAR LOCATED IN CENTER OR AT ANY POINT ALONG LENGTH OF THE PLENUM

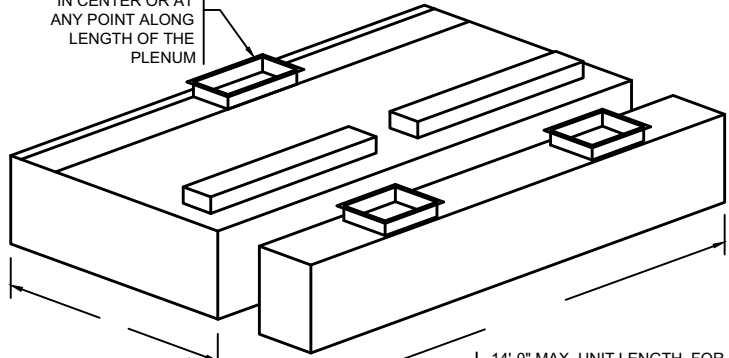

14'-0" MAX. UNIT LENGTH. FOR GREATER LENGTH, JOIN TWO OR MORE UNITS TOGETHER. ALLOW 6" MIN. OVERHANG AT EACH END. IF CHARBROILER IS AT END, OVERHANG 12"

DIMENSION VARIES WITH DEPTH OF THE EQUIPMENT AND REQUIRED OVERHANG

STANDARD LIGHT FIXTURES
 100 WATT INCANDESCENT
 RECESSED INCANDESCENT
 RECESSED FLUORESCENT
 (IF RECESSED FLUORESCENT SPECIFY SIZE)

CONSULT FACTORY FOR NON-STANDARD HEIGHTS
 22" MIN. FRONT OVERHANG
 6" MIN. SIDE OVERHANG (12" MIN. SIDE OVERHANG FOR CHARBROILER)

ITEM # _____
 EST. WEIGHT _____
 LENGTH _____
 WIDTH _____
 HEIGHT _____
 EXHAUST-CFM _____
 DUCT SIZE _____
 S.P. _____
 H.W. INLET SIZE _____
 DRAIN SIZE _____
 _____ GPM @ 40 PSI
 WATER TEMP 140°F - 180°F
 NOTE: 5 MIN. WASH CYCLE PER 24 HR PERIOD

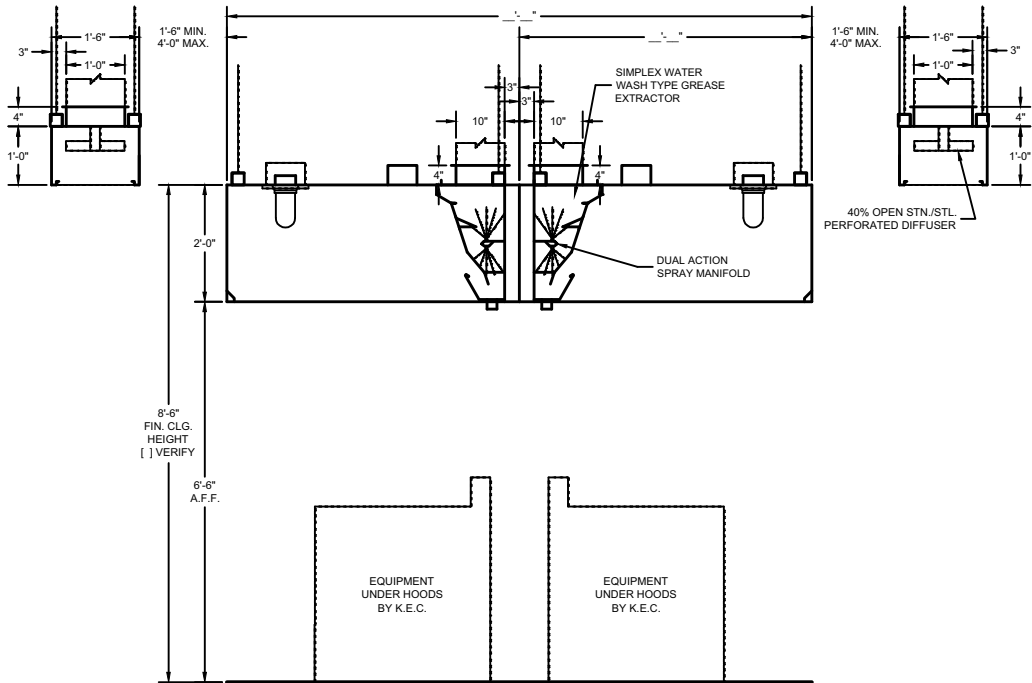

SECTION

DRAWINGS NOT TO SCALE

ENGINEERING DATA

Ventilator Length

Maximum ventilator length in a single section is 14'-0". For lengths greater than 14'-0", join two or more sections. Verify access conditions into building and kitchen space prior to length selection.

Ventilator Hanging Weight

Wt./ lineal ft.	Lbs.	105
-----------------	------	-----

NOTE: Refer to CADDY AirSystems

Master Engineering Data Sheet in engineering data section for determining light, medium, and heavy duty cooking equipment, C.F.M. requirements (exhaust and supply), duct collar sizes and static pressure requirements.

Electrical Requirements

Provide 120 volt, single phase, 60 hertz, 15 amp (min.) 24 hour service to **CADDY AirSystems** CPE control panel (refer to CPE engineering cut sheet). Control panel to be fused separately. Light fixtures to be powered by a 120/1/60 circuit.

Mechanical Requirements

The volume of exhaust required is a function of the type of cooking equipment served by the ventilator, and the type and volume of product cooked. Refer to the **CADDY AirSystems** Master Engineering Data Chart to determine exhaust volume, duct collar sizes, static pressure drop, water consumption and ventilator drain sizes.





CADDY CORPORATION

Food Service Equipment

Air Systems

Commercial Kitchen Exhaust Systems

Model SHW

Double Island Style

Model SHW-C-II Waterwash Ventilator

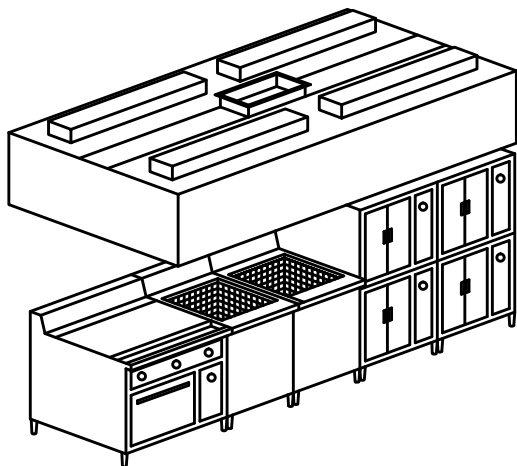

General Specifications

Furnish CADDY *AirSystems* Exhaust Hood Model **SHW-C-II** as shown on the plans and as described in the following specifications.

General

Exhaust hood shall be constructed of 18 gauge type 300 series stainless steel with all exposed surfaces a number 4 finish. Construction to meet all requirements of NFPA 96 and NSF Standard No.2. To include necessary hanger brackets at front and rear for suspending from building overhead structure.

Description

The CADDY *AirSystems* Model "SHW" Ventilator is a water-wash ventilator that is UL Listed under the standards set forth in UL 710 "Exhaust Hoods for Commercial Cooking Equipment". Each ventilator shall be a high velocity centrifugal grease extractor, with the air inlet opening parallel to the cooking equipment it serves. Each ventilator shall have three full-length horizontal baffles for centrifugal grease extraction. Each ventilator shall be equipped with one full-length wash manifold with upper and lower brass spray nozzles for superior extraction chamber cleaning action. Each ventilator shall have a grease extraction efficiency of 95% when operated within design parameters. This efficiency shall be achieved without the use of filters, cartridges, or constant running water. Ventilators shall operate at air quantities as illustrated on plans.

Accessibility and Inspection

Full length removable inspection doors shall be provided so that service can be performed on all interior components.

Automatic Washdown System

Ventilator to be equipped with one full length wash manifold with spray nozzles for automatic detergent injected wash using 140°F to 180°F hot water. Plumbing and electrical components for operation of the automatic wash system to be housed in the CADDY *AirSystems* Model "CPE" control panel.

Plumbing/Electrical

Ventilators to be factory pre-plumbed and pre-wired to a single connection point. Ventilators built in multiple sections to be furnished with unions and junction boxes for field connections by applicable trades.

Application

Island mounted exhaust-only canopy style for use over all types of cooking equipment.

Light Fixtures

All light fixtures shall be pre-wired to a single connection point. Ventilators built in multiple sections to be furnished with junction boxes for ease of field connection by the electrical trades. Light bulbs furnished and installed by the Kitchen Equipment Contractor.

Exhaust Fans

Exhaust fans are to be provided and installed by others in compliance with local codes. **Fans should be induced draft, squirrel cage design, equipped with backward inclined blades.**

Fire Protection

NFPA 96 and local codes require a fire extinguishing system for protection of the duct collar and plenum of all ventilators, as well as for the protection of various cooking appliances such as deep fat fryers, griddles, ranges, and broilers, which may be a source of ignition of grease. Consult factory and local fire officials for exact requirements. UL Listed fire protection systems may be pre-piped by Caddy at the time of manufacture, assuring concealment of piping and detectors.

Approvals

Ventilator shall be UL Listed, listed by NSF and be in accordance with all of the recommendations set forth by NFPA 96. All ventilators must meet all applicable codes.



MODEL:

SHW-C-II---

ADD THE OVERALL LENGTH (IN INCHES) OF THE VENTILATOR AFTER MODEL DESIGNATION

DAMPER TYPE
ND - NO DAMPER
FL - FUSIBLE LINK
T - THERMOSTAT

ADD THE OVERALL WIDTH (IN INCHES) OF THE VENTILATOR AFTER MODEL DESIGNATION

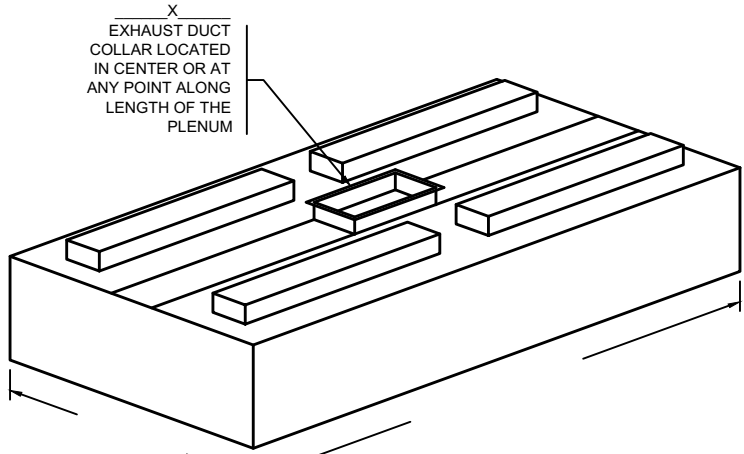

X
EXHAUST DUCT COLLAR LOCATED IN CENTER OR AT ANY POINT ALONG LENGTH OF THE PLENUM

STANDARD LIGHT FIXTURES
 100 WATT INCANDESCENT
 RECESSED INCANDESCENT
 RECESSED FLUORESCENT
 (IF RECESSED FLUORESCENT SPECIFY SIZE)

CONSULT FACTORY FOR NON-STANDARD HEIGHTS
 12" MIN. FRONT OVERHANG
 6" MIN. SIDE OVERHANG
 (12" MIN. SIDE OVERHANG FOR CHARBROILER)

ITEM # _____
 EST. WEIGHT _____
 LENGTH _____
 WIDTH _____
 HEIGHT _____
 EXHAUST-CFM _____
 DUCT SIZE _____
 S.P. _____
 H.W. INLET SIZE _____
 DRAIN SIZE _____
 _____ GPM @ 40 PSI
 WATER TEMP 140°F - 180°F
 NOTE: 5 MIN. WASH CYCLE PER 24 HR PERIOD

DIMENSION VARIES WITH DEPTH OF THE EQUIPMENT AND REQUIRED OVERHANG

14'-0" MAX. UNIT LENGTH. FOR GREATER LENGTH, JOIN TWO OR MORE UNITS TOGETHER. ALLOW 6" MIN. OVERHANG AT EACH END. IF CHARBROILER IS AT END, OVERHANG 12"

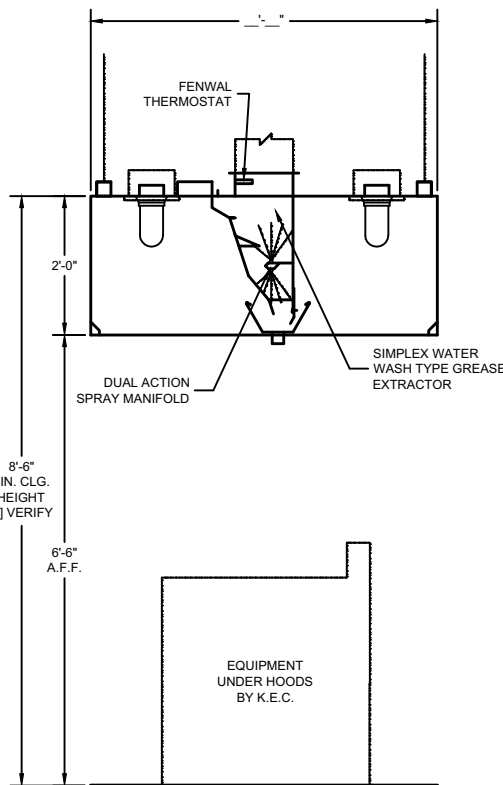

SECTION

DRAWINGS NOT TO SCALE

ENGINEERING DATA

Ventilator Length

Maximum ventilator length in a single section is 14'-0". For lengths greater than 14'-0", join two or more sections. Verify access conditions into building and kitchen space prior to length selection.

Ventilator Hanging Weight

Wt./ lineal ft.	Lbs.	90

NOTE: Refer to **CADDY AirSystems** Master Engineering Data Sheet in engineering data section for determining light, medium, and heavy duty cooking equipment, C.F.M. requirements (exhaust and supply), duct collar sizes and static pressure requirements.

Electrical Requirements

Provide 120 volt, single phase, 60 hertz, 15 amp (min.) 24 hour service to **CADDY AirSystems** CPE control panel (refer to CPE engineering cut sheet). Control panel to be fused separately. Light fixtures to be powered by a 120/1/60 circuit.

Mechanical Requirements

The volume of exhaust required is a function of the type of cooking equipment served by the ventilator, and the type and volume of product cooked. Refer to the **CADDY AirSystems** Master Engineering Data Chart to determine exhaust volume, duct collar sizes, static pressure drop, water consumption and ventilator drain sizes.



Model SHW-C-II-PA Waterwash Ventilator

ITEM NO:

PROJECT:

LOCATION:

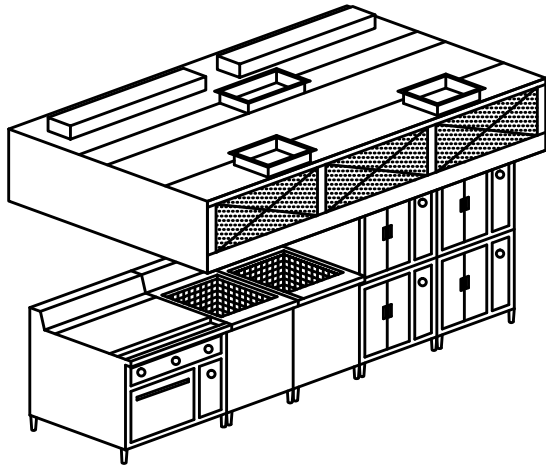

General Specifications

Furnish CADDY *AirSystems* Exhaust Hood Model **SHW-C-II-PA** as shown on the plans and as described in the following specifications.

General

Exhaust hood shall be constructed of 18 gauge type 300 series stainless steel with all exposed surfaces a number 4 finish. Construction to meet all requirements of NFPA 96 and NSF Standard No.2. To include necessary hanger brackets at front and rear for suspending from building overhead structure.

Description

The CADDY *AirSystems* Model "SHW" Ventilator is a water-wash ventilator that is UL Listed under the standards set forth in UL 710 "Exhaust Hoods for Commercial Cooking Equipment". Each ventilator shall be a high velocity centrifugal grease extractor, with the air inlet opening parallel to the cooking equipment it serves. Each ventilator shall have three full-length horizontal baffles for centrifugal grease extraction. Each ventilator shall be equipped with one full-length wash manifold with upper and lower brass spray nozzles for superior extraction chamber cleaning action. Each ventilator shall have a grease extraction efficiency of 95% when operated within design parameters. This efficiency shall be achieved without the use of filters, cartridges, or constant running water. Ventilators shall operate at air quantities as illustrated on plans.

Accessibility and Inspection

Full length removable inspection doors shall be provided so that service can be performed on all interior components.

Automatic Washdown System

Ventilator to be equipped with one full length wash manifold with spray nozzles for automatic detergent injected wash using 140°F to 180°F hot water. Plumbing and electrical components for operation of the automatic wash system to be housed in the CADDY *AirSystems* Model "CPE" control panel.

Plumbing/Electrical

Ventilators to be factory pre-plumbed and pre-wired to a single connection point. Ventilators built in multiple sections to be furnished with unions and junction boxes for filed connections by applicable trades.

Make-Up Air (Front Face Discharge)

Ventilator shall have 40% open stainless steel perforated screens along front face for discharge of tempered make-up air. Supply volume is 80% or designed to the desired air balance.

Application

Island style cooking applications for use over all types of cooking equipment where integral make-up air is required.

Light Fixtures

All light fixtures shall be pre-wired to a single connection point. Ventilators built in multiple sections to be furnished with junction boxes for ease of field connection by the electrical trades. Light bulbs furnished and installed by the Kitchen Equipment Contractor.

Exhaust Fans

Exhaust fans are to be provided and installed by others in compliance with local codes. **Fans should be induced draft, squirrel cage design, equipped with backward inclined blades.**

Fire Protection

NFPA 96 and local codes require a fire extinguishing system for protection of the duct collar and plenum of all ventilators, as well as for the protection of various cooking appliances such as deep fat fryers, griddles, ranges, and broilers, which may be a source of ignition of grease. Consult factory and local fire officials for exact requirements. UL Listed fire protection systems may be pre-piped by Caddy at the time of manufacture, assuring concealment of piping and detectors.

Approvals

Ventilator shall be UL Listed, listed by NSF and be in accordance with all of the recommendations set forth by NFPA 96. All ventilators must meet all applicable codes.





MODEL:

SHW-C-II-PA---

ADD THE OVERALL LENGTH (IN INCHES) OF THE VENTILATOR AFTER MODEL DESIGNATION

DAMPER TYPE
ND - NO DAMPER
FL - FUSIBLE LINK
T - THERMOSTAT

ADD THE OVERALL WIDTH (IN INCHES) OF THE VENTILATOR AFTER MODEL DESIGNATION

X
EXHAUST DUCT COLLAR LOCATED IN CENTER OR AT ANY POINT ALONG LENGTH OF THE PLENUM

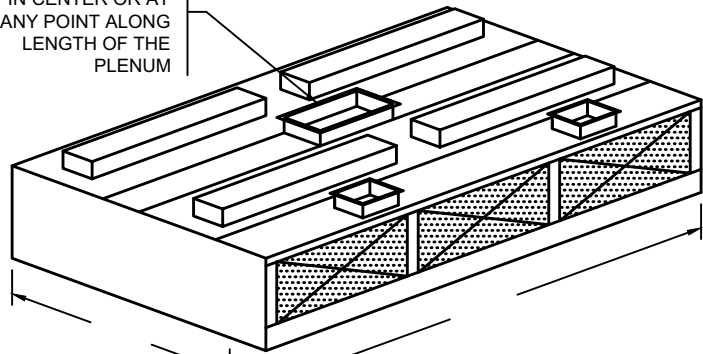

DIMENSION VARIES WITH DEPTH OF THE EQUIPMENT AND REQUIRED OVERHANG

14'-0" MAX. UNIT LENGTH. FOR GREATER LENGTH, JOIN TWO OR MORE UNITS TOGETHER. ALLOW 6" MIN. OVERHANG AT EACH END. IF CHARBROILER IS AT END, OVERHANG 12"

STANDARD LIGHT FIXTURES
 100 WATT INCANDESCENT
 RECESSED INCANDESCENT
 RECESSED FLUORESCENT
 (IF RECESSED FLUORESCENT SPECIFY SIZE)

CONSULT FACTORY FOR NON-STANDARD HEIGHTS
 12" MIN. FRONT OVERHANG
 6" MIN. SIDE OVERHANG (12" MIN. SIDE OVERHANG FOR CHARBROILER)

ITEM # _____
 EST. WEIGHT _____
 LENGTH _____
 WIDTH _____
 HEIGHT _____
 EXHAUST-CFM _____
 DUCT SIZE _____
 S.P. _____
 H.W. INLET SIZE _____
 DRAIN SIZE _____

____ GPM @ 40 PSI
 WATER TEMP 140°F - 180°F
 NOTE: 5 MIN. WASH CYCLE PER 24 HR PERIOD

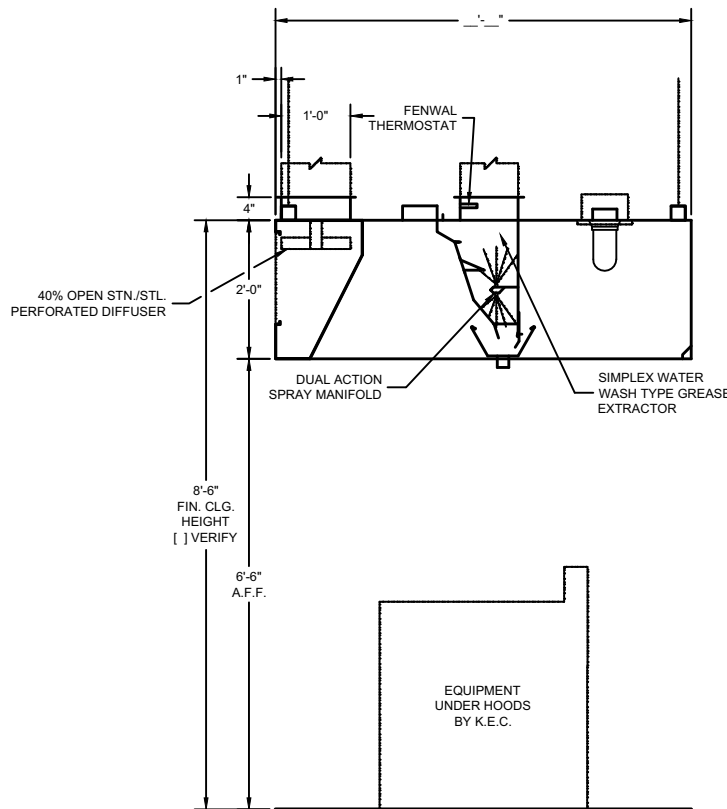

SECTION

DRAWINGS NOT TO SCALE

ENGINEERING DATA

Ventilator Length

Maximum ventilator length in a single section is 14'-0". For lengths greater than 14'-0", join two or more sections. Verify access conditions into building and kitchen space prior to length selection.

Ventilator Hanging Weight

Wt./ lineal ft.	Lbs.	105
-----------------	------	-----

NOTE: Refer to **CADDY AirSystems**

Master Engineering Data Sheet in engineering data section for determining light, medium, and heavy duty cooking equipment, C.F.M. requirements (exhaust and supply), duct collar sizes and static pressure requirements.

Electrical Requirements

Provide 120 volt, single phase, 60 hertz, 15 amp (min.) 24 hour service to **CADDY AirSystems** CPE control panel (refer to CPE engineering cut sheet). Control panel to be fused separately. Light fixtures to be powered by a 120/1/60 circuit.

Mechanical Requirements

The volume of exhaust required is a function of the type of cooking equipment served by the ventilator, and the type and volume of product cooked. Refer to the **CADDY AirSystems** Master Engineering Data Chart to determine exhaust volume, duct collar sizes, static pressure drop, water consumption and ventilator drain sizes.



Model SHW-C-II-ASI Waterwash Ventilator

ITEM NO:

PROJECT:

LOCATION:

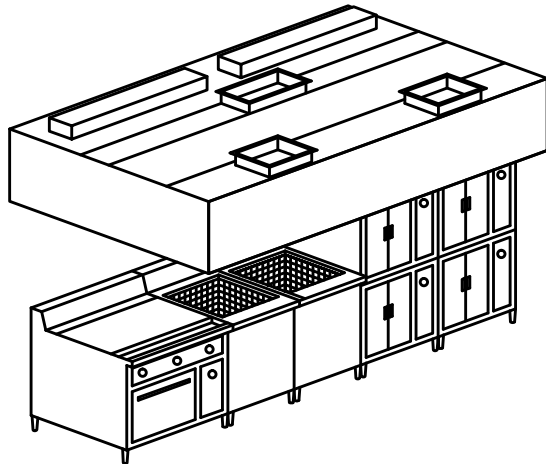

General Specifications

Furnish CADDY *AirSystems* Exhaust Hood Model **SHW-C-II-ASI** as shown on the plans and as described in the following specifications.

General

Exhaust hood shall be constructed of 18 gauge type 300 series stainless steel with all exposed surfaces a number 4 finish. Construction to meet all requirements of NFPA 96 and NSF Standard No.2. To include necessary hanger brackets at front and rear for suspending from building overhead structure.

Description

The CADDY *AirSystems* Model "SHW" Ventilator is a water-wash ventilator that is UL Listed under the standards set forth in UL 710 "Exhaust Hoods for Commercial Cooking Equipment". Each ventilator shall be a high velocity centrifugal grease extractor, with the air inlet opening parallel to the cooking equipment it serves. Each ventilator shall have three full-length horizontal baffles for centrifugal grease extraction. Each ventilator shall be equipped with one full-length wash manifold with upper and lower brass spray nozzles for superior extraction chamber cleaning action. Each ventilator shall have a grease extraction efficiency of 95% when operated within design parameters. This efficiency shall be achieved without the use of filters, cartridges, or constant running water. Ventilators shall operate at air quantities as illustrated on plans.

Accessibility and Inspection

Full length removable inspection doors shall be provided so that service can be performed on all interior components.

Automatic Washdown System

Ventilator to be equipped with one full length wash manifold with spray nozzles for automatic detergent injected wash using 140°F to 180°F hot water. Plumbing and electrical components for operation of the automatic wash system to be housed in the CADDY *AirSystems* Model "CPE" control panel.

Plumbing/Electrical

Ventilators to be factory pre-plumbed and pre-wired to a single connection point. Ventilators built in multiple sections to be furnished with unions and junction boxes for filed connections by applicable trades.

Make-Up Air (Internal Discharge)

Ventilator shall have a fully insulated supply plenum with duct collar/fire damper assemblies and air registers internally mounted for discharging untempered make-up air directly into canopy of ventilator. The amount of make-up air supplied through this design is directly related to the type of cooking equipment located beneath the hood. The percentage of supply air distributed will vary as a function of the thermal currents generated by each individual appliance. When specifying this style, consult factory for specific supply volumes. This air may be untempered in most areas, depending upon climatic conditions and the type of cooking equipment.

Application

Island style cooking applications for use over all types of cooking equipment where integral make-up air is required.

Light Fixtures

All light fixtures shall be pre-wired to a single connection point. Ventilators built in multiple sections to be furnished with junction boxes for ease of field connection by the electrical trades. Light bulbs furnished and installed by the Kitchen Equipment Contractor.

Exhaust Fans

Exhaust fans are to be provided and installed by others in compliance with local codes. **Fans should be induced draft, squirrel cage design, equipped with backward inclined blades.**

Fire Protection

NFPA 96 and local codes require a fire extinguishing system for protection of the duct collar and plenum of all ventilators, as well as for the protection of various cooking appliances such as deep fat fryers, griddles, ranges, and broilers, which may be a source of ignition of grease. Consult factory and local fire officials for exact requirements. UL Listed fire protection systems may be pre-piped by Caddy at the time of manufacture, assuring concealment of piping and detectors.

Approvals

Ventilator shall be UL Listed, listed by NSF and be in accordance with all of the recommendations set forth by NFPA 96. All ventilators must meet all applicable codes.

 **CADDY CORPORATION**
509 Sharptown Road P.O. Box 345
Bridgeport, NJ 08014-0345
Tel: 856-467-4222 Fax: 856-467-5511
internet: www.caddycorp.com



MODEL:

SHW-C-II-ASI---

ADD THE OVERALL LENGTH (IN INCHES) OF THE VENTILATOR AFTER MODEL DESIGNATION

DAMPER TYPE
ND - NO DAMPER
FL - FUSIBLE LINK
T - THERMOSTAT

ADD THE OVERALL WIDTH (IN INCHES) OF THE VENTILATOR AFTER MODEL DESIGNATION

X
EXHAUST DUCT COLLAR LOCATED IN CENTER OR AT ANY POINT ALONG LENGTH OF THE PLENUM

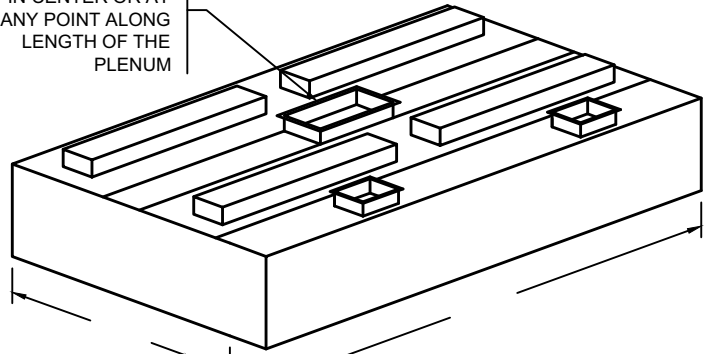

DIMENSION VARIES WITH DEPTH OF THE EQUIPMENT AND REQUIRED OVERHANG

14'-0" MAX. UNIT LENGTH. FOR GREATER LENGTH, JOIN TWO OR MORE UNITS TOGETHER. ALLOW 6" MIN. OVERHANG AT EACH END. IF CHARBROILER IS AT END, OVERHANG 12"

STANDARD LIGHT FIXTURES
 100 WATT INCANDESCENT
 RECESSED INCANDESCENT
 RECESSED FLUORESCENT
 (IF RECESSED FLUORESCENT SPECIFY SIZE)

CONSULT FACTORY FOR NON-STANDARD HEIGHTS
 22" MIN. FRONT OVERHANG
 6" MIN. SIDE OVERHANG
 (12" MIN. SIDE OVERHANG FOR CHARBROILER)

ITEM # _____
 EST. WEIGHT _____
 LENGTH _____
 WIDTH _____
 HEIGHT _____
 EXHAUST-CFM _____
 DUCT SIZE _____
 S.P. _____
 H.W. INLET SIZE _____
 DRAIN SIZE _____
 _____ GPM @ 40 PSI
 WATER TEMP 140°F - 180°F
 NOTE: 5 MIN. WASH CYCLE PER 24 HR PERIOD

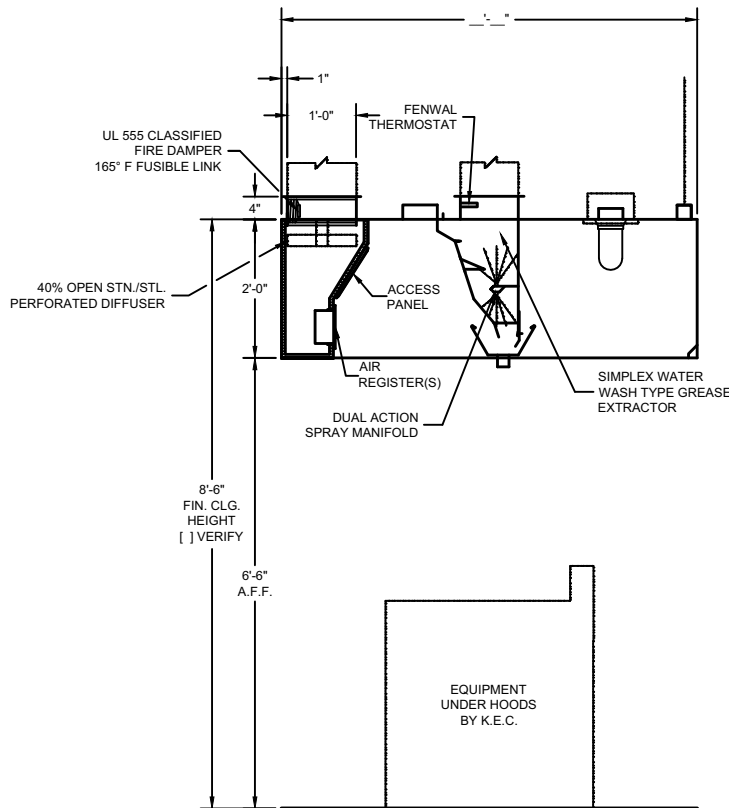

SECTION

DRAWINGS NOT TO SCALE

ENGINEERING DATA

Ventilator Length

Maximum ventilator length in a single section is 14'-0". For lengths greater than 14'-0", join two or more sections. Verify access conditions into building and kitchen space prior to length selection.

Ventilator Hanging Weight

Wt./ lineal ft.	Lbs.	105
-----------------	------	-----

NOTE: Refer to **CADDY AirSystems**

Master Engineering Data Sheet in engineering data section for determining light, medium, and heavy duty cooking equipment, C.F.M. requirements (exhaust and supply), duct collar sizes and static pressure requirements.

Electrical Requirements

Provide 120 volt, single phase, 60 hertz, 15 amp (min.) 24 hour service to **CADDY AirSystems** CPE control panel (refer to CPE engineering cut sheet). Control panel to be fused separately. Light fixtures to be powered by a 120/1/60 circuit.

Mechanical Requirements

The volume of exhaust required is a function of the type of cooking equipment served by the ventilator, and the type and volume of product cooked. Refer to the **CADDY AirSystems** Master Engineering Data Chart to determine exhaust volume, duct collar sizes, static pressure drop, water consumption and ventilator drain sizes.



Model SHW-C-II-AA Waterwash Ventilator

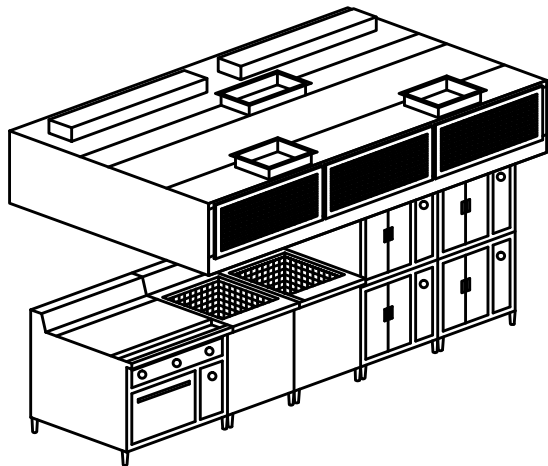

General Specifications

Furnish CADDY *AirSystems* Exhaust Hood Model **SHW-C-II-AA** as shown on the plans and as described in the following specifications.

General

Exhaust hood shall be constructed of 18 gauge type 300 series stainless steel with all exposed surfaces a number 4 finish. Construction to meet all requirements of NFPA 96 and NSF Standard No.2. To include necessary hanger brackets at front and rear for suspending from building overhead structure.

Description

The CADDY *AirSystems* Model "SHW" Ventilator is a water-wash ventilator that is UL Listed under the standards set forth in UL 710 "Exhaust Hoods for Commercial Cooking Equipment". Each ventilator shall be a high velocity centrifugal grease extractor, with the air inlet opening parallel to the cooking equipment it serves. Each ventilator shall have three full-length horizontal baffles for centrifugal grease extraction. Each ventilator shall be equipped with one full-length wash manifold with upper and lower brass spray nozzles for superior extraction chamber cleaning action. Each ventilator shall have a grease extraction efficiency of 95% when operated within design parameters. This efficiency shall be achieved without the use of filters, cartridges, or constant running water. Ventilators shall operate at air quantities as illustrated on plans.

Accessibility and Inspection

Full length removable inspection doors shall be provided so that service can be performed on all interior components.

Automatic Washdown System

Ventilator to be equipped with one full length wash manifold with spray nozzles for automatic detergent injected wash using 140°F to 180°F hot water. Plumbing and electrical components for operation of the automatic wash system to be housed in the CADDY *AirSystems* Model "CPE" control panel.

Plumbing/Electrical

Ventilators to be factory pre-plumbed and pre-wired to a single connection point. Ventilators built in multiple sections to be furnished with unions and junction boxes for field connections by applicable trades.

Make-Up Air (Front Face Register Discharge)

Ventilator shall have air registers along front face for discharge of tempered make-up air. Supply volume is 80%, or designed to the desired air balance.

Application

Island style cooking applications for use over all types of cooking equipment where integral make-up air is required.

Light Fixtures

All light fixtures shall be pre-wired to a single connection point. Ventilators built in multiple sections to be furnished with junction boxes for ease of field connection by the electrical trades. Light bulbs furnished and installed by the Kitchen Equipment Contractor.

Exhaust Fans

Exhaust fans are to be provided and installed by others in compliance with local codes. **Fans should be induced draft, squirrel cage design, equipped with backward inclined blades.**

Fire Protection

NFPA 96 and local codes require a fire extinguishing system for protection of the duct collar and plenum of all ventilators, as well as for the protection of various cooking appliances such as deep fat fryers, griddles, ranges, and broilers, which may be a source of ignition of grease. Consult factory and local fire officials for exact requirements. UL Listed fire protection systems may be pre-piped by Caddy at the time of manufacture, assuring concealment of piping and detectors.

Approvals

Ventilator shall be UL Listed, listed by NSF and be in accordance with all of the recommendations set forth by NFPA 96. All ventilators must meet all applicable codes.



MODEL:

SHW-C-II-AA---

ADD THE OVERALL LENGTH (IN INCHES) OF THE VENTILATOR AFTER MODEL DESIGNATION

DAMPER TYPE
ND - NO DAMPER
FL - FUSIBLE LINK
T - THERMOSTAT

ADD THE OVERALL WIDTH (IN INCHES) OF THE VENTILATOR AFTER MODEL DESIGNATION

X
EXHAUST DUCT COLLAR LOCATED IN CENTER OR AT ANY POINT ALONG LENGTH OF THE PLENUM

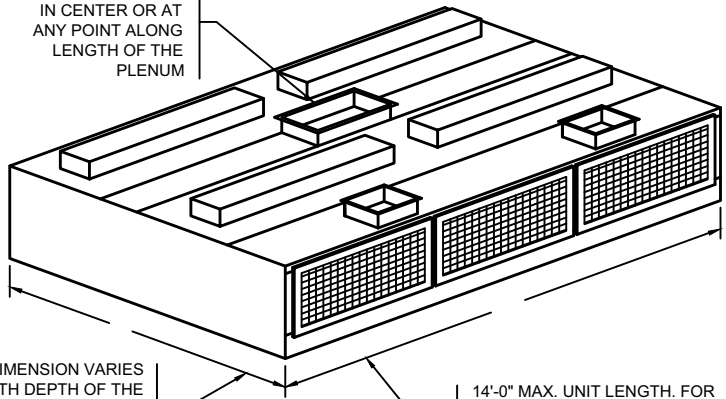

DIMENSION VARIES WITH DEPTH OF THE EQUIPMENT AND REQUIRED OVERHANG

14'-0" MAX. UNIT LENGTH. FOR GREATER LENGTH, JOIN TWO OR MORE UNITS TOGETHER. ALLOW 6" MIN. OVERHANG AT EACH END. IF CHARBROILER IS AT END, OVERHANG 12"

STANDARD LIGHT FIXTURES
 100 WATT INCANDESCENT
 RECESSED INCANDESCENT
 RECESSED FLUORESCENT
 (IF RECESSED FLUORESCENT SPECIFY SIZE)

CONSULT FACTORY FOR NON-STANDARD HEIGHTS
 12" MIN. FRONT OVERHANG
 6" MIN. SIDE OVERHANG
 (12" MIN. SIDE OVERHANG FOR CHARBROILER)

ITEM # _____
 EST. WEIGHT _____
 LENGTH _____
 WIDTH _____
 HEIGHT _____
 EXHAUST-CFM _____
 DUCT SIZE _____
 S.P. _____
 H.W. INLET SIZE _____
 DRAIN SIZE _____

____ GPM @ 40 PSI
 WATER TEMP 140°F - 180°F
 NOTE: 5 MIN. WASH CYCLE PER 24 HR PERIOD

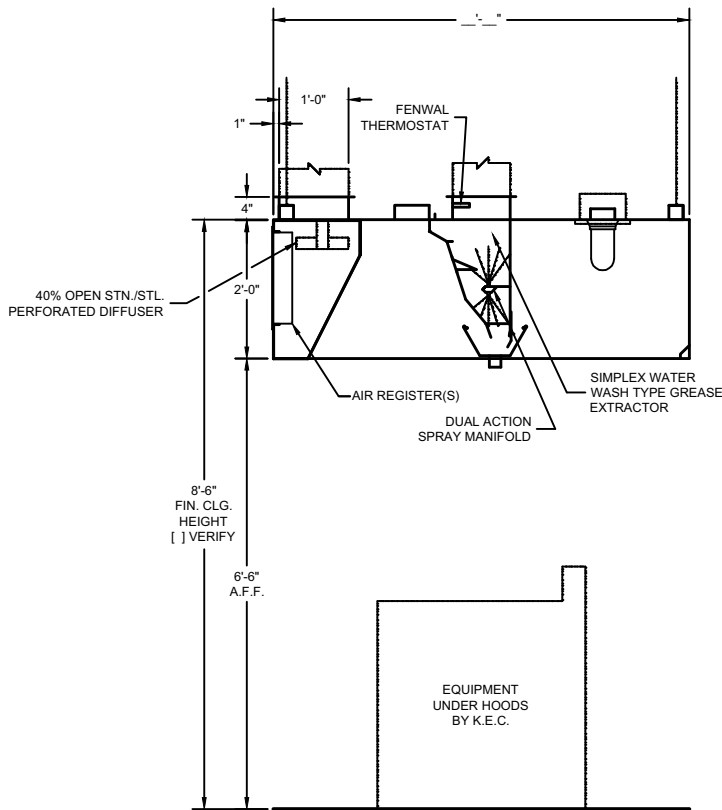

SECTION

DRAWINGS NOT TO SCALE

ENGINEERING DATA

Ventilator Length

Maximum ventilator length in a single section is 14'-0". For lengths greater than 14'-0", join two or more sections. Verify access conditions into building and kitchen space prior to length selection.

Ventilator Hanging Weight

Wt./ lineal ft.	Lbs.	105
-----------------	------	-----

NOTE: Refer to CADDY AirSystems

Master Engineering Data Sheet in engineering data section for determining light, medium, and heavy duty cooking equipment, C.F.M. requirements (exhaust and supply), duct collar sizes and static pressure requirements.

Electrical Requirements

Provide 120 volt, single phase, 60 hertz, 15 amp (min.) 24 hour service to **CADDY AirSystems** CPE control panel (refer to CPE engineering cut sheet). Control panel to be fused separately. Light fixtures to be powered by a 120/1/60 circuit.

Mechanical Requirements

The volume of exhaust required is a function of the type of cooking equipment served by the ventilator, and the type and volume of product cooked. Refer to the **CADDY AirSystems** Master Engineering Data Chart to determine exhaust volume, duct collar sizes, static pressure drop, water consumption and ventilator drain sizes.



Model SHW-C-II-ASII Waterwash Ventilator

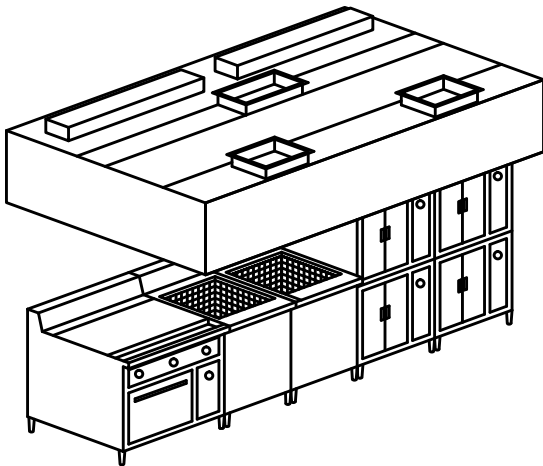

General Specifications

Furnish CADDY *AirSystems* Exhaust Hood Model **SHW-C-II-ASII** as shown on the plans and as described in the following specifications.

General

Exhaust hood shall be constructed of 18 gauge type 300 series stainless steel with all exposed surfaces a number 4 finish. Construction to meet all requirements of NFPA 96 and NSF Standard No.2. To include necessary hanger brackets at front and rear for suspending from building overhead structure.

Description

The CADDY *AirSystems* Model "SHW" Ventilator is a water-wash ventilator that is UL Listed under the standards set forth in UL 710 "Exhaust Hoods for Commercial Cooking Equipment". Each ventilator shall be a high velocity centrifugal grease extractor, with the air inlet opening parallel to the cooking equipment it serves. Each ventilator shall have three full-length horizontal baffles for centrifugal grease extraction. Each ventilator shall be equipped with one full-length wash manifold with upper and lower brass spray nozzles for superior extraction chamber cleaning action. Each ventilator shall have a grease extraction efficiency of 95% when operated within design parameters. This efficiency shall be achieved without the use of filters, cartridges, or constant running water. Ventilators shall operate at air quantities as illustrated on plans.

Accessibility and Inspection

Full length removable inspection doors shall be provided so that service can be performed on all interior components.

Automatic Washdown System

Ventilator to be equipped with one full length wash manifold with spray nozzles for automatic detergent injected wash using 140°F to 180°F hot water. Plumbing and electrical components for operation of the automatic wash system to be housed in the CADDY *AirSystems* Model "CPE" control panel.

Plumbing/Electrical

Ventilators to be factory pre-plumbed and pre-wired to a single connection point. Ventilators built in multiple sections to be furnished with unions and junction boxes for field connections by applicable trades.

Make-Up Air (Perimeter Down Discharge)

Ventilator shall have air registers along perimeter for down discharge of tempered make-up. Supply volume is 80% or designed to the desired air balance.

Application

Island style cooking applications for use over all types of cooking equipment where integral make-up air is required.

Light Fixtures

All light fixtures shall be pre-wired to a single connection point. Ventilators built in multiple sections to be furnished with junction boxes for ease of field connection by the electrical trades. Light bulbs furnished and installed by the Kitchen Equipment Contractor.

Exhaust Fans

Exhaust fans are to be provided and installed by others in compliance with local codes. **Fans should be induced draft, squirrel cage design, equipped with backward inclined blades.**

Fire Protection

NFPA 96 and local codes require a fire extinguishing system for protection of the duct collar and plenum of all ventilators, as well as for the protection of various cooking appliances such as deep fat fryers, griddles, ranges, and broilers, which may be a source of ignition of grease. Consult factory and local fire officials for exact requirements. UL Listed fire protection systems may be pre-piped by Caddy at the time of manufacture, assuring concealment of piping and detectors.

Approvals

Ventilator shall be UL Listed, listed by NSF and be in accordance with all of the recommendations set forth by NFPA 96. All ventilators must meet all applicable codes.



MODEL:

SHW-C-II-ASII---

ADD THE OVERALL LENGTH (IN INCHES) OF THE VENTILATOR AFTER MODEL DESIGNATION

DAMPER TYPE
ND - NO DAMPER
FL - FUSIBLE LINK
T - THERMOSTAT

ADD THE OVERALL WIDTH (IN INCHES) OF THE VENTILATOR AFTER MODEL DESIGNATION

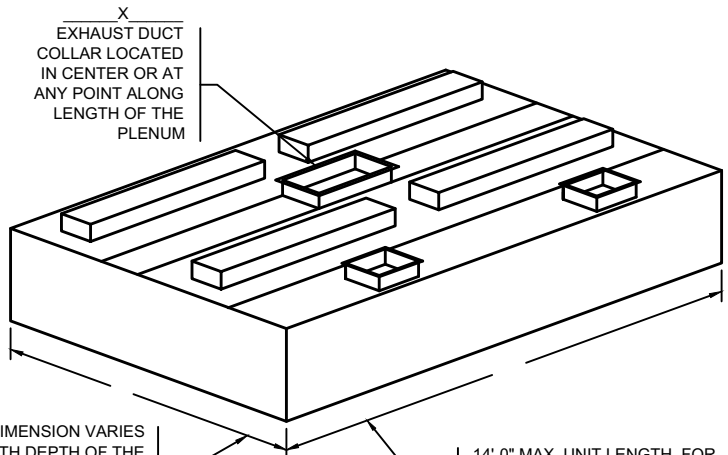

DIMENSION VARIES WITH DEPTH OF THE EQUIPMENT AND REQUIRED OVERHANG

14'-0" MAX. UNIT LENGTH. FOR GREATER LENGTH, JOIN TWO OR MORE UNITS TOGETHER. ALLOW 6" MIN. OVERHANG AT EACH END. IF CHARBROILER IS AT END, OVERHANG 12"

STANDARD LIGHT FIXTURES
 100 WATT INCANDESCENT
 RECESSED INCANDESCENT
 RECESSED FLUORESCENT
 (IF RECESSED FLUORESCENT SPECIFY SIZE)

CONSULT FACTORY FOR NON-STANDARD HEIGHTS
 22" MIN. FRONT OVERHANG
 6" MIN. SIDE OVERHANG (12" MIN. SIDE OVERHANG FOR CHARBROILER)

ITEM # _____
 EST. WEIGHT _____
 LENGTH _____
 WIDTH _____
 HEIGHT _____
 EXHAUST-CFM _____
 DUCT SIZE _____
 S.P. _____
 H.W. INLET SIZE _____
 DRAIN SIZE _____
 _____ GPM @ 40 PSI
 WATER TEMP 140°F - 180°F
 NOTE: 5 MIN. WASH CYCLE PER 24 HR PERIOD

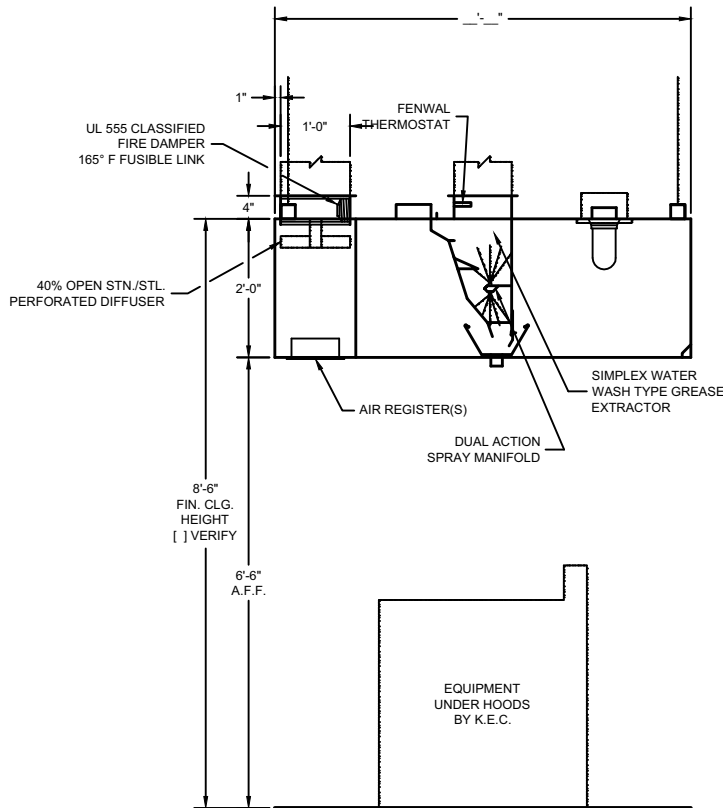

SECTION

DRAWINGS NOT TO SCALE

ENGINEERING DATA

Ventilator Length

Maximum ventilator length in a single section is 14'-0". For lengths greater than 14'-0", join two or more sections. Verify access conditions into building and kitchen space prior to length selection.

Ventilator Hanging Weight

Wt./ lineal ft.	Lbs.	105
-----------------	------	-----

NOTE: Refer to CADDY AirSystems

Master Engineering Data Sheet in engineering data section for determining light, medium, and heavy duty cooking equipment, C.F.M. requirements (exhaust and supply), duct collar sizes and static pressure requirements.

Electrical Requirements

Provide 120 volt, single phase, 60 hertz, 15 amp (min.) 24 hour service to CADDY AirSystems CPE control panel (refer to CPE engineering cut sheet). Control panel to be fused separately. Light fixtures to be powered by a 120/1/60 circuit.

Mechanical Requirements

The volume of exhaust required is a function of the type of cooking equipment served by the ventilator, and the type and volume of product cooked. Refer to the CADDY AirSystems Master Engineering Data Chart to determine exhaust volume, duct collar sizes, static pressure drop, water consumption and ventilator drain sizes.



Model SHW-C-II

Waterwash Ventilator With Ceiling Supply Plenum

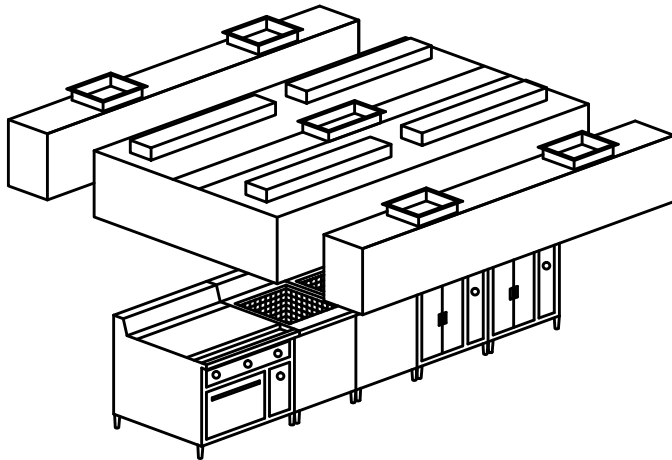

General Specifications

Furnish CADDY *AirSystems* Exhaust Hood Model **SHW-C-II-ASII** as shown on the plans and as described in the following specifications.

General

Exhaust hood shall be constructed of 18 gauge type 300 series stainless steel with all exposed surfaces a number 4 finish. Construction to meet all requirements of NFPA 96 and NSF Standard No.2. To include necessary hanger brackets at front and rear for suspending from building overhead structure.

Description

The CADDY *AirSystems* Model "SHW" Ventilator is a water-wash ventilator that is UL Listed under the standards set forth in UL 710 "Exhaust Hoods for Commercial Cooking Equipment". Each ventilator shall be a high velocity centrifugal grease extractor, with the air inlet opening parallel to the cooking equipment it serves. Each ventilator shall have three full-length horizontal baffles for centrifugal grease extraction. Each ventilator shall be equipped with one full-length wash manifold with upper and lower brass spray nozzles for superior extraction chamber cleaning action. Each ventilator shall have a grease extraction efficiency of 95% when operated within design parameters. This efficiency shall be achieved without the use of filters, cartridges, or constant running water. Ventilators shall operate at air quantities as illustrated on plans.

Accessibility and Inspection

Full length removable inspection doors shall be provided so that service can be performed on all interior components.

Automatic Washdown System

Ventilator to be equipped with one full length wash manifold with spray nozzles for automatic detergent injected wash using 140°F to 180°F hot water. Plumbing and electrical components for operation of the automatic wash system to be housed in the CADDY *AirSystems* Model "CPE" control panel.

Plumbing/Electrical

Ventilators to be factory pre-plumbed and pre-wired to a single connection point. Ventilators built in multiple sections to be furnished with unions and junction boxes for field connections by applicable trades.

Make-Up Air (Perimeter Down Discharge)

Ventilator shall have air registers along perimeter for down discharge of tempered make-up. Supply volume is 80% or designed to the desired air balance.

Application

Island style cooking applications for use over all types of cooking equipment where integral make-up air is required.

Light Fixtures

All light fixtures shall be pre-wired to a single connection point. Ventilators built in multiple sections to be furnished with junction boxes for ease of field connection by the electrical trades. Light bulbs furnished and installed by the Kitchen Equipment Contractor.

Exhaust Fans

Exhaust fans are to be provided and installed by others in compliance with local codes. **Fans should be induced draft, squirrel cage design, equipped with backward inclined blades.**

Fire Protection

NFPA 96 and local codes require a fire extinguishing system for protection of the duct collar and plenum of all ventilators, as well as for the protection of various cooking appliances such as deep fat fryers, griddles, ranges, and broilers, which may be a source of ignition of grease. Consult factory and local fire officials for exact requirements. UL Listed fire protection systems may be pre-piped by Caddy at the time of manufacture, assuring concealment of piping and detectors.

Approvals

Ventilator shall be UL Listed, listed by NSF and be in accordance with all of the recommendations set forth by NFPA 96. All ventilators must meet all applicable codes.



MODEL:

SHW-C-II- [] - [] - []

ADD THE OVERALL LENGTH (IN INCHES) OF THE VENTILATOR AFTER MODEL DESIGNATION

DAMPER TYPE
ND - NO DAMPER
FL - FUSIBLE LINK
T - THERMOSTAT

ADD THE OVERALL WIDTH (IN INCHES) OF THE VENTILATOR AFTER MODEL DESIGNATION

X
EXHAUST DUCT COLLAR LOCATED IN CENTER OR AT ANY POINT ALONG LENGTH OF THE PLENUM

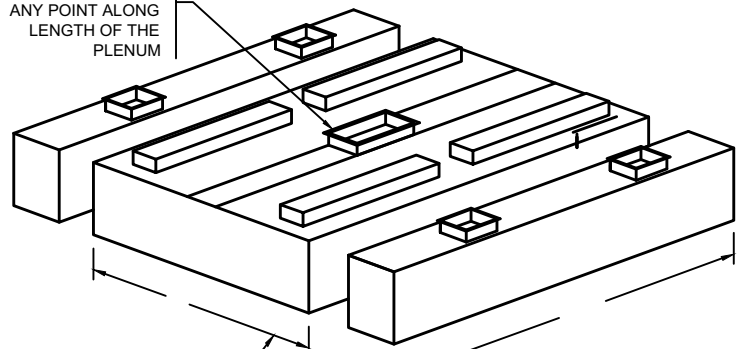

DIMENSION VARIES WITH DEPTH OF THE EQUIPMENT AND REQUIRED OVERHANG

14'-0" MAX. UNIT LENGTH. FOR GREATER LENGTH, JOIN TWO OR MORE UNITS TOGETHER. ALLOW 6" MIN. OVERHANG AT EACH END. IF CHARBROILER IS AT END, OVERHANG 12"

STANDARD LIGHT FIXTURES
() 100 WATT INCANDESCENT
() RECESSED INCANDESCENT
() RECESSED FLUORESCENT
(IF RECESSED FLUORESCENT SPECIFY SIZE)

CONSULT FACTORY FOR NON-STANDARD HEIGHTS
22" MIN. FRONT OVERHANG
6" MIN. SIDE OVERHANG
(12" MIN. SIDE OVERHANG FOR CHARBROILER)

ITEM # _____
EST. WEIGHT _____
LENGTH _____
WIDTH _____
HEIGHT _____
EXHAUST-CFM _____
DUCT SIZE _____
S.P. _____
H.W. INLET SIZE _____
DRAIN SIZE _____
____ GPM @ 40 PSI
WATER TEMP 140°F - 180°F
NOTE: 5 MIN. WASH CYCLE PER 24 HR PERIOD

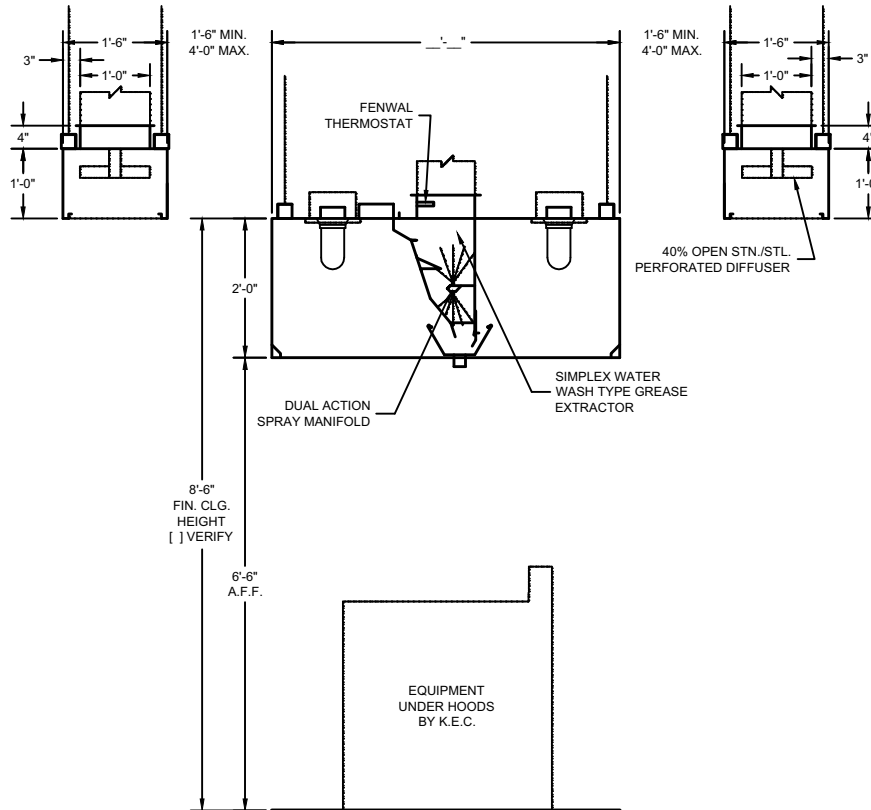

SECTION

DRAWINGS NOT TO SCALE

ENGINEERING DATA

Ventilator Length

Maximum ventilator length in a single section is 14'-0". For lengths greater than 14'-0", join two or more sections. Verify access conditions into building and kitchen space prior to length selection.

Ventilator Hanging Weight

Wt./ lineal ft.	Lbs.	105
-----------------	------	-----

NOTE: Refer to CADDY AirSystems

Master Engineering Data Sheet in engineering data section for determining light, medium, and heavy duty cooking equipment, C.F.M. requirements (exhaust and supply), duct collar sizes and static pressure requirements.

Electrical Requirements

Provide 120 volt, single phase, 60 hertz, 15 amp (min.) 24 hour service to **CADDY AirSystems** CPE control panel (refer to CPE engineering cut sheet). Control panel to be fused separately. Light fixtures to be powered by a 120/1/60 circuit.

Mechanical Requirements

The volume of exhaust required is a function of the type of cooking equipment served by the ventilator, and the type and volume of product cooked. Refer to the **CADDY AirSystems** Master Engineering Data Chart to determine exhaust volume, duct collar sizes, static pressure drop, water consumption and ventilator drain sizes.





CADDY CORPORATION

Food Service Equipment

Air Systems

Commercial Kitchen Exhaust Systems

Model SHW
Eyebrow Style

Model SHW-BK-W Waterwash Ventilator

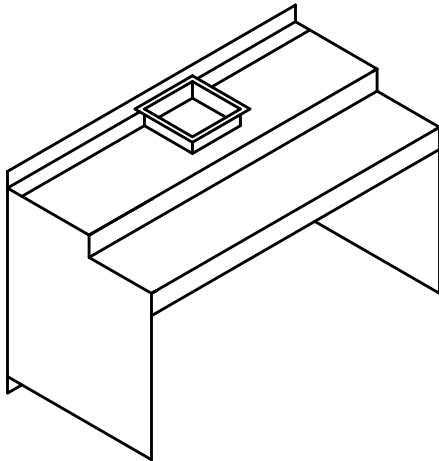

General Specifications

Furnish CADDY *AirSystems* Exhaust Hood Model **SHW-BK-W** as shown on the plans and as described in the following specifications.

General

Exhaust hood shall be constructed of 18 gauge type 300 series stainless steel with all exposed surfaces a number 4 finish. Construction to meet all requirements of NFPA 96 and NSF Standard No.2. To include necessary hanger brackets at front and rear for suspending from building overhead structure.

Description

The CADDY *AirSystems* Model "SHW" Ventilator is a water-wash ventilator that is UL Listed under the standards set forth in UL 710 "Exhaust Hoods for Commercial Cooking Equipment". Each ventilator shall be a high velocity centrifugal grease extractor, with the air inlet opening parallel to the cooking equipment it serves. Each ventilator shall have three full-length horizontal baffles for centrifugal grease extraction. Each ventilator shall be equipped with one full-length wash manifold with upper and lower brass spray nozzles for superior extraction chamber cleaning action. Each ventilator shall have a grease extraction efficiency of 95% when operated within design parameters. This efficiency shall be achieved without the use of filters, cartridges, or constant running water. Ventilators shall operate at air quantities as illustrated on plans.

Accessibility and Inspection

Full length removable inspection doors shall be provided so that service can be performed on all interior components.

Automatic Washdown System

Ventilator to be equipped with one full length wash manifold with spray nozzles for automatic detergent injected wash using 140°F to 180°F hot water. Plumbing and electrical components for operation of the automatic wash system to be housed in the CADDY *AirSystems* Model "CPE" control panel.

Plumbing/Electrical

Ventilators to be factory pre-plumbed and pre-wired to a single connection point. Ventilators built in multiple sections to be furnished with unions and junction boxes for filed connections by applicable trades.

Application

Eyebrow style for direct mounting to roast, bake, reel and pizza ovens.

Exhaust Fans

Exhaust fans are to be provided and installed by others in compliance with local codes. **Fans should be induced draft, squirrel cage design, equipped with backward inclined blades.**

Fire Protection

NFPA 96 and local codes require a fire extinguishing system for protection of the duct collar and plenum of all ventilators, as well as for the protection of various cooking appliances such as deep fat fryers, griddles, ranges, and broilers, which may be a source of ignition of grease. Consult factory and local fire officials for exact requirements. UL Listed fire protection systems may be pre-piped by Caddy at the time of manufacture, assuring concealment of piping and detectors.

Approvals

Ventilator shall be UL Listed, listed by NSF and be in accordance with all of the recommendations set forth by NFPA 96. All ventilators must meet all applicable codes.



MODEL:

SHW-BK-W---

ADD THE OVERALL LENGTH (IN INCHES) OF THE VENTILATOR AFTER MODEL DESIGNATION

DAMPER TYPE
ND - NO DAMPER
FL - FUSIBLE LINK
T - THERMOSTAT

ADD THE OVERALL WIDTH (IN INCHES) OF THE VENTILATOR AFTER MODEL DESIGNATION

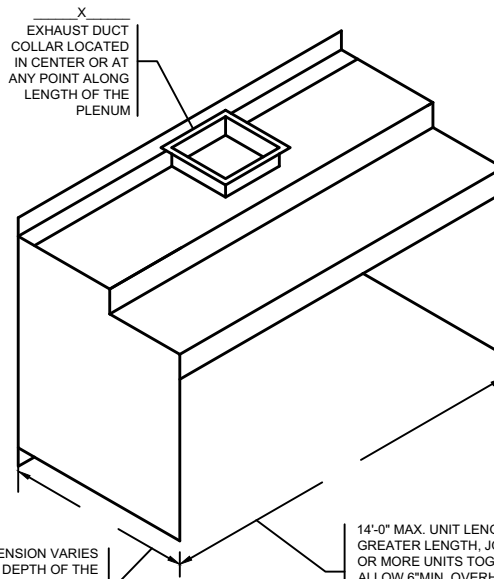

DIMENSION VARIES WITH DEPTH OF THE EQUIPMENT AND REQUIRED OVERHANG

14'-0" MAX. UNIT LENGTH. FOR GREATER LENGTH, JOIN TWO OR MORE UNITS TOGETHER. ALLOW 6" MIN. OVERHANG AT EACH END. IF CHARBROILER IS AT END, OVERHANG 12"

STANDARD LIGHT FIXTURES
 100 WATT INCANDESCENT
 RECESSED INCANDESCENT
 RECESSED FLUORESCENT
 (IF RECESSED FLUORESCENT SPECIFY SIZE)

CONSULT FACTORY FOR NON-STANDARD HEIGHTS

- ITEM # _____
- EST. WEIGHT _____
- LENGTH _____
- WIDTH _____
- HEIGHT _____
- EXHAUST-CFM _____
- DUCT SIZE _____
- S.P. _____
- H.W. INLET SIZE _____
- DRAIN SIZE _____

___ GPM @ 40 PSI

WATER TEMP 140°F - 180°F

NOTE: 5 MIN. WASH CYCLE PER 24 HR PERIOD

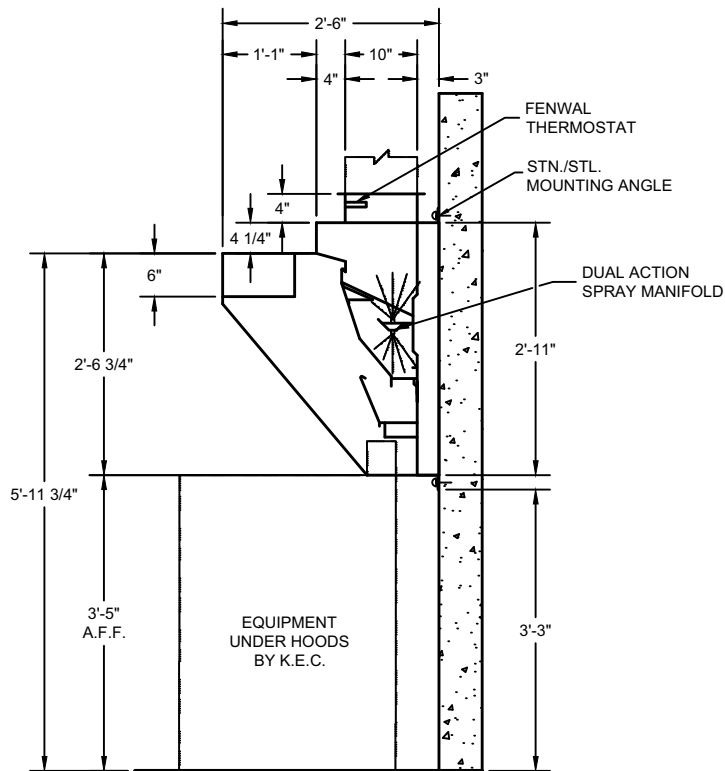

SECTION Z-Z

DRAWINGS NOT TO SCALE

ENGINEERING DATA

Ventilator Length

Maximum ventilator length in a single section is 14'-0". For lengths greater than 14'-0", join two or more sections. Verify access conditions into building and kitchen space prior to length selection.

Ventilator Hanging Weight

Wt./ lineal ft.	Lbs.	75

NOTE: Refer to **CADDY AirSystems**

Master Engineering Data Sheet in engineering data section for determining light, medium, and heavy duty cooking equipment, C.F.M. requirements (exhaust and supply), duct collar sizes and static pressure requirements.

Electrical Requirements

Provide 120 volt, single phase, 60 hertz, 15 amp (min.) 24 hour service to **CADDY AirSystems** CPE control panel (refer to CPE engineering cut sheet). Control panel to be fused separately. Light fixtures to be powered by a 120/1/60 circuit.

Mechanical Requirements

The volume of exhaust required is a function of the type of cooking equipment served by the ventilator, and the type and volume of product cooked. Refer to the **CADDY AirSystems** Master Engineering Data Chart to determine exhaust volume, duct collar sizes, static pressure drop, water consumption and ventilator drain sizes.





CADDY CORPORATION

Food Service Equipment

Air Systems

Control Cabinets for Water-Wash Ventilators

Model CPE

Model CPE Control Cabinets for Water-Wash Ventilators

ITEM NO:

PROJECT:

LOCATION:

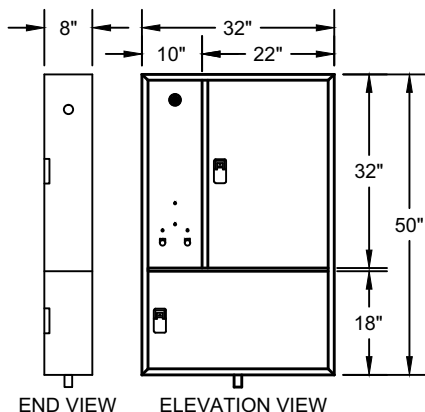

MODEL CPE-1.25-RP-TC

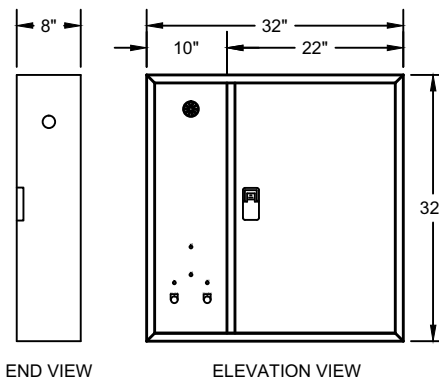

MODEL CPE-1.25-TC

General Description (Non-sequential)

The CADDY Air Systems Model CPE waterwash control panel is designed to work in conjunction with series "SH-W" ventilator. This panel houses all necessary plumbing and electrical components required to manually control the exhaust fan, operate the wash cycle, and control the internal fire protection system. Panel to include _____ vacuum breaker and check valve shipped loose for installation by the Plumbing Contractor _____ a built-in reduced pressure (RP) type backflow preventor as required by the Uniform Plumbing Code (UPC), state and/or codes.

General Description (Sequential)

The CADDY Air Systems Model CPE waterwash control panel is designed to work in conjunction with series "SH-W" ventilator. This the of panel is typically required when the building hot water system is not capable of delivering enough hot water to wash hoods during a single period of time. This panel houses all necessary plumbing and electrical components required to manually control the exhaust fan, operate the wash cycle, and control the internal fire protection system. Panel to include built-in reduced pressure (RP) type backflow preventor as required by the Uniform Plumbing Code (UPC), state and/or codes. This panel is designed to wash two or more groups of ventilators in sequence (up to four groups maximum), with a programmable delay period between each group to allow for hot water regeneration. Upon wash sequence activation, the exhaust fan shuts down automatically, and the first wash cycle is initiated. At the end of the first wash cycle, there is a programmable delay of up to 120 minutes. The wash cycle for the next group begins at the end of the previous delay period. This sequence of operation continues of up to four groups. The wash cycle length is factory set at 5 minutes for optimal cleaning. Each wash cycle duration can be field adjusted from 1-14 minutes, depending upon internal grease accumulations.

Time Clock Operation (Optional)

Model CPE and CPE-S will include a 24 hour per day, seven day operation is required. This clock is located within the electrical compartment of the panel, where it is not subject to tampering. Features include: LCD digital display, independent daily programming capability, multiple start fan and start wash times, Holiday skip feature, power back-up for holding clock setting and daily programming requirements.

Number of Panels Required

One control panel can be used for multiple hood sections as long as the total lineal footage of ventilator does not exceed the pipe size limitations of the panel. (Non-sequential). One control panel can be used for multiple hoods in a group wash configuration up to four groups, as long as the total lineal footage of ventilator in each group does not exceed the pipe size limitations of the panel. (Sequential). See "Hot Water Pipe Inlet Size" chart below for panel limitations. Any number of exhaust fans can be interconnected to these panels if simultaneous operation of fans single control panel, consult factory for wiring details.

Model Number Designation

In order to determine the exact panel model number, it is first necessary to identify which of the following options are desired. Each selected option becomes an identifiable suffix in the model number.

1. Number of groups in sequence (if applicable).. 2,3 or 4
2. Built-in backflow preventor (if applicable)..... RP
3. Programmable time clock..... TC
4. Low detergent alarm..... LD
5. Cold water mist..... CM
6. Pipe inlet size (inches)..... 75,1.00,1.25 or 1.50

Once options are selected, identify the exact panel model number as illustrated by the following example:

CPE - S_____ - RP - TC - LD - CM - _____
 Prefix No. of Groups Built-in Time Low Cold Pipe
 in Sequence Backflow Clock Detergent Water
 (if Applicable) Preventor Alarm Mist
 (if Applicable)

Installation

The CPE control panel is shipped as a separate component and is to be installed, wired and plumbed by the applicable field trades. This panel can be either surface or flush mounted. When flush mounted, specify panel with stainless steel trim ring.

Hot Water Requirements

- 140 Deg. F. minimum - 180 Deg. F. maximum
- 40psi minimum - 80 psi maximum
- Average wash cycle duration - minutes per 24 hour period
- 1.00 FPM per lineal foot of ventilator at 40 psi
- 1.25 GPM per lineal foot of ventilator at 80 psi

Control Panel Dimensions

- All non-sequential panels without built-in backflow preventor are 32" W x 32" H x 8" D
- All non-sequential panels with built-in backflow preventor are 32" W x 50" H x 8" D
- All sequential panels up to a three sequence configuration (S-3) are 32" W x 50" H x 8" D
- All sequential panels with a four sequence configuration (S-4) are 32" W x 54" H x 8" D

Control Panel Weights

- All non-sequential panels : 100 LBS.
- All sequential panels: 150 LBS.

Electrial Requirments

120 volt, 60 HZ, 15 amp (minimum) non-interrupted service.

CADDY CORPORATION
 509 Sharptown Road P.O. Box 345
 Bridgeport, NJ 08014-0345
 Tel: 856-467-4222 Fax: 856-467-5511
 internet: www.caddycorp.com

COMPONENT DETAILS (NON- SEQUENTIAL)

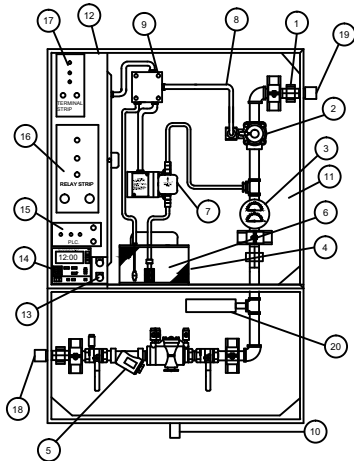

MODEL CPE-1.25-RP-TC

LEGEND

1. UNION (TYPICAL)
2. WATER SOLENOID VALVES (S)
3. PRESSURE/TEMPERATURE GAUGE
4. DETERGENT RESERVOIR
5. BACKFLOW PREVENTER (RP DEVICE) WITH 1/4 TURN SHUT OFF VALVE
6. DETERGENT LINE WITH FOOT VALVE
7. DETERGENT PUMP
8. WATERTIGHT FLEX CONDUIT (TYPICAL)
9. WATERTIGHT POWER DISTRIBUTION JUNCTION BOX
10. 1" "RP" DRAIN
11. PLUMBING COMPARTMENT
12. ELECTRICAL COMPARTMENT
13. FIRE TEST STATION
14. PROGRAMMABLE TIME CLOCK (OPTIONAL)
15. PROGRAMMABLE LOGIC CONTROLLER
16. INTERNAL RELAY STRIP
17. FIELD WIRING TERMINAL STRIP
18. HOT WATER INLET
19. HOT WATER OUTLET (TYPICAL)
20. WATER HAMMER

General Specifications (Sequential)

CADDY *AirSystems* control panel model **CPE-S-RP** _____ to be furnished with "SH-W" Series waterwash ventilators. This panel shall house all plumbing and electrical components required to service the ventilators. The panel shall be constructed of minimum 18 gauge type 304 stainless steel with a number 4 finish, with welded corners and hinged doors to the plumbing and electrical compartments. The electrical compartment shall be water tight to protect against direct hose spray. Electrical controls shall include a programmable logic controller (PLC) for control of the exhaust fan, wash cycle and internal fire protection system. The face of the panel shall be equipped with system status indicator lights which include "Fan On", "Wash On", and "Fire Mode". An audio alarm to indicate "Fire Mode" is also standard. The control panel shall be capable of washing up to four groups of ventilators in sequence, with a delay period for hot water regeneration between each group. The length of each cycle shall be factory pre-set at five minutes per group. The length of each delay period shall be field variable. Panel shall

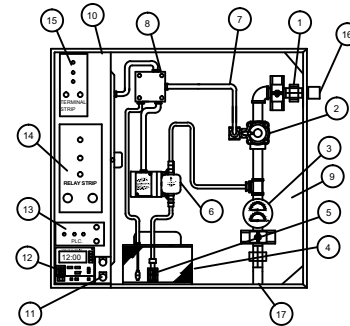

MODEL CPE-1.25-TC

LEGEND

1. UNION (TYPICAL)
2. WATER SOLENOID VALVES (S)
3. PRESSURE/TEMPERATURE GAUGE
4. DETERGENT RESERVOIR
5. DETERGENT LINE WITH FOOT VALVE
6. DETERGENT PUMP
7. WATERTIGHT FLEX CONDUIT (TYPICAL)
8. WATERTIGHT POWER DISTRIBUTION JUNCTION BOX
9. PLUMBING COMPARTMENT
10. ELECTRICAL COMPARTMENT
11. FIRE TEST STATION
12. PROGRAMMABLE TIME CLOCK (OPTIONAL)
13. PROGRAMMABLE LOGIC CONTROLLER
14. INTERNAL RELAY STRIP
15. FIELD WIRING TERMINAL STRIP
16. HOT WATER OUTLET
17. HOT WATER INLET

also be equipped with volt-free contacts to allow for connection to a remote exhaust and supply fan motor control center. Contacts are also provided to allow for interconnection between the internal and system. Plumbing components to include a water shut-off valve, pressure/ temperature gauge, normally closed water solenoid valve, detergent pump with extended foot valve, detergent tank and built-in reduced pressure (RP) principle device back flow preventor. Panel shall be equipped with a catch basin compartment with a 1" drain connection to facilitate required testing of the "RP" device as required by code. All components shall be pre-wired and pre-plumbed for field connection by applicable trades. Control cabinet shall be U.L. listed.

General Specifications (Non-sequential)

CADDY *AirSystems* control panel model **CPE-**_____ to be furnished with "SH-W" Series waterwash ventilators. This panel shall house all plumbing and electrical components required to service the ventilators. The panel shall be constructed of minimum 18 gauge type 304 stainless steel with a number 4 finish, with welded corners and hinged doors to the plumbing

CADDY CORPORATION
 509 Sharptown Road P.O. Box 345
 Bridgeport, NJ 08014-0345
 Tel: 856-467-4222 Fax: 856-467-5511
 internet: www.caddycorp.com

COMPONENT DETAILS (SEQUENTIAL)

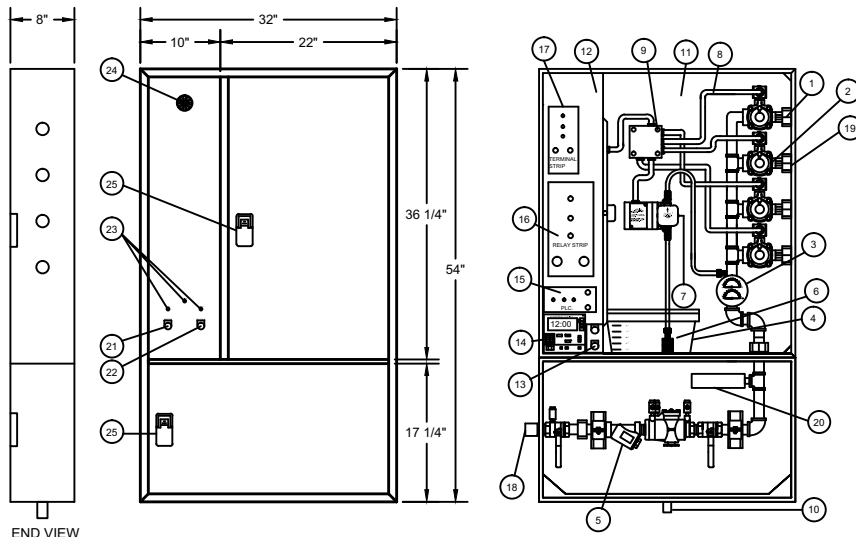

MODEL CPE-S-4-1.25-RP-TC

LEGEND

- | | |
|--|---|
| 1. UNION (TYPICAL) | 13. FIRE TEST STATION |
| 2. WATER SOLENOID VALVES (S) | 14. PROGRAMMABLE TIME CLOCK (OPTIONAL) |
| 3. PRESSURE/TEMPERATURE GAUGE | 15. PROGRAMMABLE LOGIC CONTROLLER |
| 4. DETERGENT RESERVOIR | 16. INTERNAL RELAY STRIP |
| 5. BACKFLOW PREVENTER (RP DEVICE) WITH 1/4 TURN SHUT OFF VALVE | 17. FIELD WIRING TERMINAL STRIP |
| 6. DETERGENT LINE WITH FOOT VALVE | 18. HOT WATER INLET |
| 7. DETERGENT PUMP | 19. HOT WATER OUTLET (TYPICAL) |
| 8. WATERTIGHT FLEX CONDUIT (TYPICAL) | 20. WATER HAMMER |
| 9. WATERTIGHT POWER DISTRIBUTION JUNCTION BOX | 21. START FAN SWITCH |
| 10. 1" "RP" DRAIN | 22. START WASH SWITCH |
| 11. PLUMBING COMPARTMENT | 23. SYSTEM STATUS INDICATOR LIGHTS |
| 12. ELECTRICAL COMPARTMENT | 24. SON ALERT AUDIBLE ALARM |
| | 25. RECESSED HANDLE FOR PLUMBING COMPARTMENT ACCESS |

and electrical compartments. The electrical compartment shall be water tight to protect against direct hose spray. Electrical controls shall include a programmable logic controller (PLC) for control of the exhaust fan, wash cycle and internal fire protection system. The face of the panel shall be equipped with system status indicator lights which include "Fan On", "Wash On", and "Fire Mode". An audio alarm to indicate "Fire Mode" is also standard. Panel shall also be equipped with volt-free contacts to allow for connection to a remote exhaust and supply fan motor control center. Contacts are also provided to allow for interconnection between the internal and system. Plumbing components to include water shut-off valve, pressure/ temperature gauge, normally closed water solenoid valve, detergent pump with extended foot valve, detergent tank and _____ vacuum breaker/check valve shipped loose for installation by the Plumbing Contractor (standard), _____ built-in reduced pressure (RP) principle device back flow preventor (optional). When specified with an "RP" device as required by code. All components shall be pre-wired and pre-plumbed for field connection by applicable trades. Control cabinet shall be U.L. listed.

Optional Features (Non-Sequential and Sequential)

___ Time Clock-- To include a 24 hour, 7 day solid state LCD programmable time clock for automatic operation. Program options to include starting and stopping the exhaust fan and starting the wash cycle automatically at a pre-determined time of day. Time clock to be equipped with an internal battery back-up to hold the programmed time and programmed memory functions.

___ Low Detergent Alarm-- To include a low detergent flow switch to initiate a visual alarm when detergent drops below a pre-set level in the reservoir.

___ Continuous Cold Water Mist-- To include provisions for continuous cold water mist for use over solid fuel burning cooking equipment. Components of manifold to include shut-off valve, solenoid valve, pressure regulator and pressure gauge.

___ Remote Fire Switch-- To include a remote break-glass type fire switch for installation at the nearest exit as indicated on the plans.

___ Security Package-- To include a keyed latch to prevent unauthorized access in the control panel.

CADDY CORPORATION
 509 Sharptown Road P.O. Box 345
 Bridgeport, NJ 08014-0345
 Tel: 856-467-4222 Fax: 856-467-5511
 internet: www.caddycorp.com

TYPICAL PLUMBING AND ELECTRICAL INFORMATION

PLUMBING REQUIREMENTS-NON "RP" TYPE

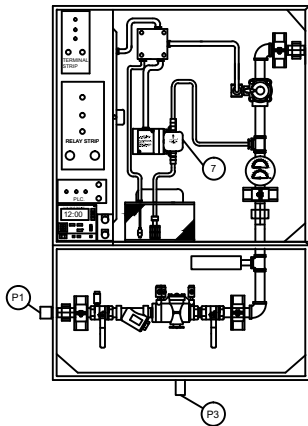

(SHOWN WITH DOOR REMOVED FRONT ELEVATION)

PLUMBING NOTES

- P1 ___" Hot water connection to CPE panel by plumbing contractor. Minimum water temp. = 140° F Maximum water temp. = 180° F Operating pressure between 40-80 PSI.
- P2 ___" Hot water connection(s) from CPE panel to hood connection(s) by plumbing contractor.
- P3 1" drain connection to floor sink by plumbing contractor.

WATER CONSUMPTION

___ G.P.M. @ 40 P.S.I. 5 min. wash cycle per 24 hr. period.

PLUMBING REQUIREMENTS- "RP" TYPE

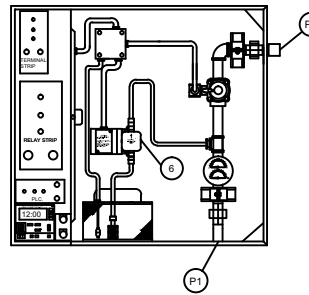

(SHOWN WITH DOOR REMOVED FRONT ELEVATION)

PLUMBING NOTES

- P1 ___" Hot water connection to CPE panel by plumbing contractor. Minimum water temp. = 140° F Maximum water temp. = 180° F Operating pressure between 40-80 PSI.
- P2 ___" Hot water connection(s) from CPE panel to hood connection(s) by plumbing contractor.

WATER CONSUMPTION

___ G.P.M. @ 40 P.S.I. 5 min. wash cycle per 24 hr. period.

NOTE: Vacuum breaker and check valve assembly shipped loose for installation by plumbing contractor.

HOT WATER PIPE INLET SIZE CHART

Total Linear Feet of Ventilator	NPT Size
3'-0" to 12'-0"	3/4"
12'-0" to 22'-0"	1"
22'-0" to 44'-0"	1 1/4"
44'-0" to 60'-0"	1 1/2"

IMPORTANT NOTE: The pipe inlet size for a sequential control panel is to be the same size as the pipe size required for the largest wash group.

TYPICAL ELECTRICAL INFORMATION

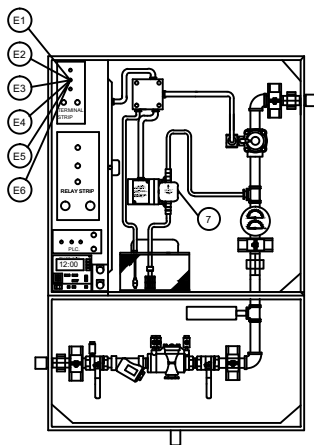

ELECTRICAL INFORMATION

- E1 120/1/60 15A. (min.) service by electrical contractor.
- E2* 4 wires from control panel to hood exhaust damper control boxes by electrical contractor.
- E3 2 wires from control panel to exhaust fan magnetic starter holding coil by electrical contractor. Holding coil to be 120v /1 phase. Supply fan to be wired in parallel with exhaust fan.
- E4 2 wires from alarm terminal dry contacts (N.O. or N.C.) located in control panel to building alarm system by alarm contractor or electrical contractor.
- E5 2 wires from remote fire pull station (if required) to FS1 and FS2 terminals in control panel by electrical contractor.
- E6 2 wires from Ansul micro switch (N.O. contacts) to Ansul 1 and Ansul 2 terminals in control panel by electrical contractor (if required).
- *- 5 wire loop between hood damper controls only by electrical contractor. See damper wiring control circuit diagram.

CADDY CORPORATION
 509 Sharptown Road P.O. Box 345
 Bridgeport, NJ 08014-0345
 Tel: 856-467-4222 Fax: 856-467-5511
 internet: www.caddycorp.com

WIRING DIAGRAM AND NOTES

120 VOLT A.C. 1 PHASE 60 HZ. 15 AMPS.
SERVICE BY ELECTRICAL CONTRACTOR

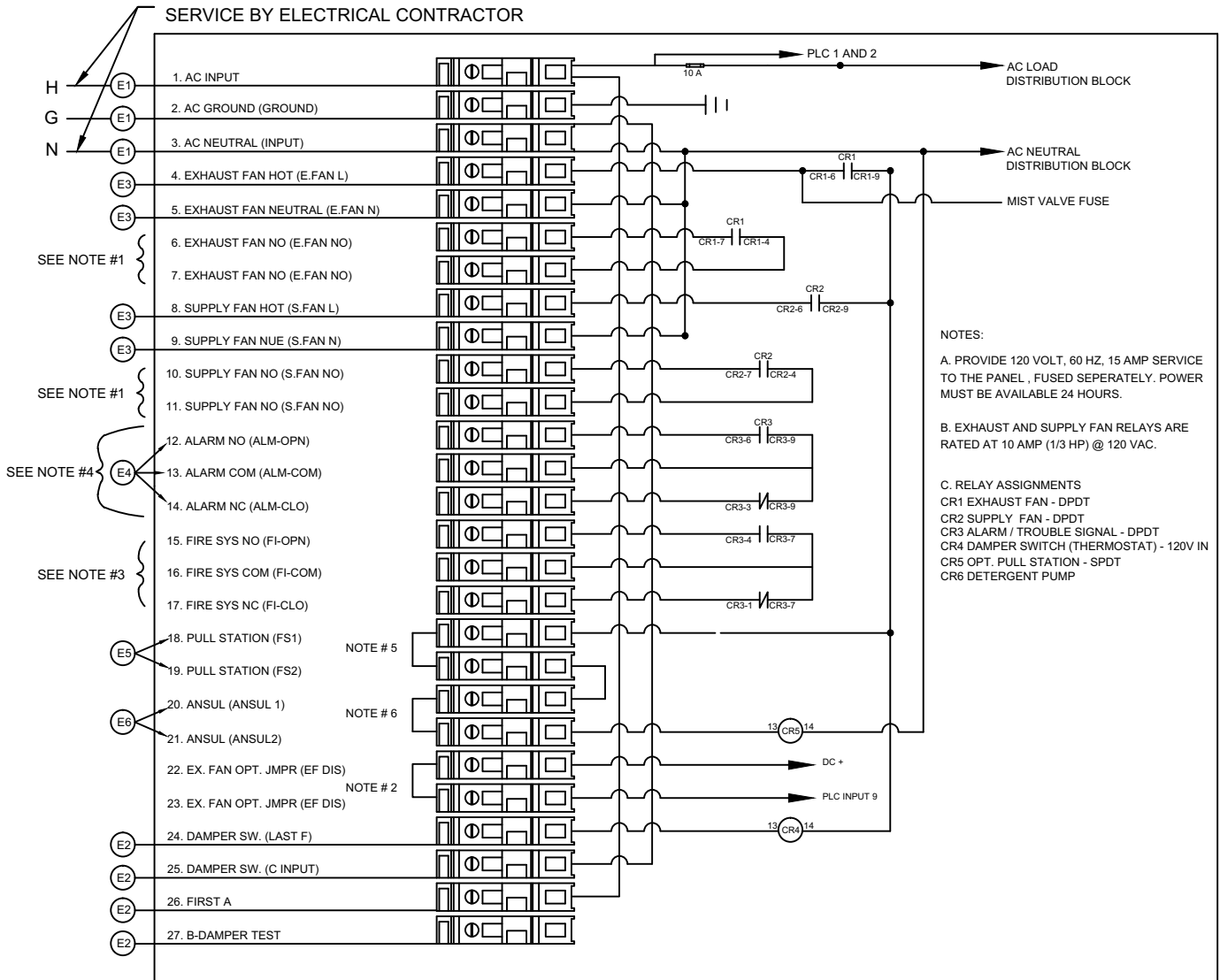

- NOTES:
- A. PROVIDE 120 VOLT, 60 HZ, 15 AMP SERVICE TO THE PANEL, FUSED SEPERATELY. POWER MUST BE AVAILABLE 24 HOURS.
 - B. EXHAUST AND SUPPLY FAN RELAYS ARE RATED AT 10 AMP (1/3 HP) @ 120 VAC.
 - C. RELAY ASSIGNMENTS
 CR1 EXHAUST FAN - DPDT
 CR2 SUPPLY FAN - DPDT
 CR3 ALARM / TROUBLE SIGNAL - DPDT
 CR4 DAMPER SWITCH (THERMOSTAT) - 120V IN
 CR5 OPT. PULL STATION - SPDT
 CR6 DETERGENT PUMP

- Exhaust fan N/O and supply fan N/O terminals are voltage free N/O sets of contacts for use with a remote motor control station.

SEQUENCE OF OPERATIONS

"FAN ON" - contacts close to start exhaust and supply fans.
 "Wash on" - Contacts open to stop exhaust and supply fans.
 "External fire" (fire switch pulled, fire system discharged)
 Exhaust fan N/O contacts close to start exhaust fan.
 Supply fan N/O contacts open to stop supply fan.

"Internal fire" (ventilator thermostat closure) contacts open to stop exhaust and supply fan.

- Unit is shipped with a factory installed jumper across exhaust fan disable terminals. With jumper installed "external fire" condition will result in exhaust and supply fan shutdown. Removal of jumper will cause exhaust fan to start, if off, or remain running if on, and supply fan to stop during external fire condition.

- Alarm com., alarm N/C, alarm N/O-voltage free contacts for connection to building alarm system. Contacts transfer during either internal or external fire mode.

- Alarm com., alarm N/C, alarm N/O-voltage free contacts for connection to building alarm system. Contacts transfer during either internal or external fire mode. (Optional)

- Factory installed jumper. Removed jumper and install N/C remote fire switch if required. Pulling switch will initiate external fire mode.

- Factory installed jumper. Removed jumper and connect to N/C micro switch in Ansul, Kidde, or Pyrochem system. Fire system discharge will initiate external fire mode.

CADDY CORPORATION
 509 Sharptown Road P.O. Box 345
 Bridgeport, NJ 08014-0345
 Tel: 856-467-4222 Fax: 856-467-5511
 internet: www.caddycorp.com

120 VOLT A.C. 1 PHASE
60 HZ. 15 AMPS. SERVICE BY
ELECTRICAL CONTRACTOR

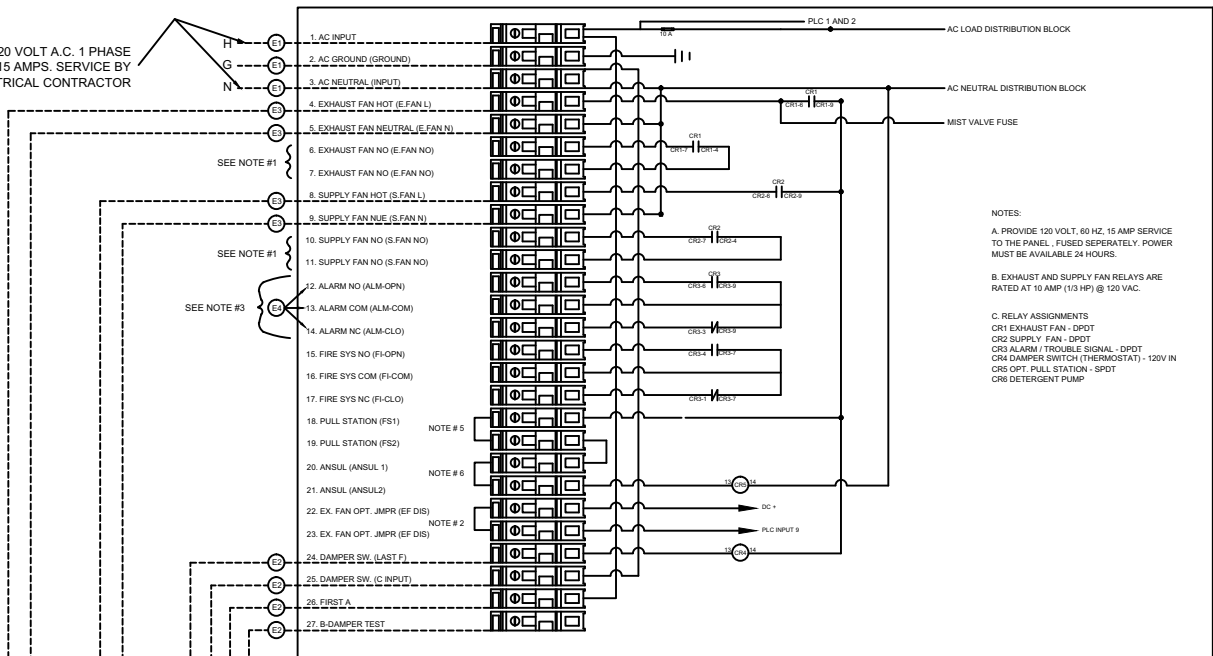

- NOTES:
- A. PROVIDE 120 VOLT, 60 HZ, 15 AMP SERVICE TO THE PANEL, FUSED SEPARATELY. POWER MUST BE AVAILABLE 24 HOURS.
 - B. EXHAUST AND SUPPLY FAN RELAYS ARE RATED AT 10 AMP (1/3 HP) @ 120 VAC.
 - C. RELAY ASSIGNMENTS
 CR1 EXHAUST FAN - DPDT
 CR2 SUPPLY FAN - DPDT
 CR3 ALARM TROUBLE SIGNAL - DPDT
 CR4 DAMPER SWITCH (THERMOSTAT) - 120V IN
 CR5 OPT. PULL STATION - SPDT
 CR6 DETERGENT PUMP

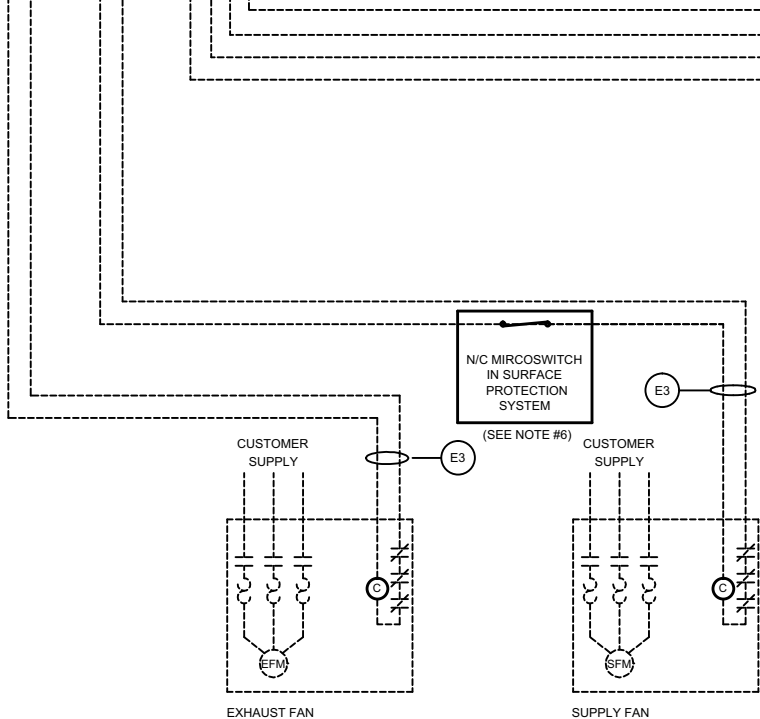

EXHAUST FAN
MOTOR STARTER
MAGNETIC STARTER
WIRING DIAGRAM MAY
VARY ACCORDING TO
MAKE OF STARTER
HOWEVER, COIL MUST
BE 115 VOLTS.

SUPPLY FAN
MOTOR STARTER
MAGNETIC STARTER
WIRING DIAGRAM MAY
VARY ACCORDING TO
MAKE OF STARTER
HOWEVER, COIL MUST
BE 115 VOLTS.

————— BY CADDY AIR SYSTEMS
 - - - - - BY ELECTRICAL CONTRACTOR

GENERAL CONTRACT CONDITIONS.

ELECTRICAL WORK DONE BY CADDY CORPORATION OF AMERICA IS EXECUTED IN COMPLIANCE WITH STANDARDS PUBLISHED BY THE UNDERWRITERS LABORATORIES, INC. INsofar AS APPLICABLE, AND THE LATEST EDITION OF THE NATIONAL ELECTRICAL CODE (NEC). CADDY CORPORATION OF AMERICA DOES NOT ACCEPT ANY RESPONSIBILITY FOR THE REQUIREMENTS OF ANY REGIONAL AND/OR LOCAL CODES THAT ADD OR DEVIATE FROM THE ACCEPTED STANDARDS OF THE ABOVE AGENCIES.
 ANY FIELD WORK RELATING TO THE MODIFICATION OF ELECTRIC OR PLUMBING SYSTEMS TO MEET REGIONAL OR LOCAL CODE REQUIREMENTS IS TO BE DONE BY OTHERS AND WITHOUT BACK CHARGE TO CADDY CORPORATION OF AMERICA, UNLESS THESE CONDITIONS WERE PREVIOUSLY BROUGHT TO OUR ATTENTION AND ARE EXPRESSLY INCLUDED IN OUR WRITTEN QUOTATION.
 ALL WIRING AND PLUMBING AT THE JOB SITE IS THE RESPONSIBILITY OF OTHERS. EQUIPMENT WILL BE CONSTRUCTED IN ACCORDANCE WITH OUR DRAWING(S) WHICH MUST BE APPROVED PRIOR TO FABRICATION. ANY SUBSEQUENT CHANGES REQUIRED MUST BE SUBMITTED TO US IN WRITING AND ACKNOWLEDGED ON OUR STANDARD FORM.

CADDY CORPORATION
 509 Sharptown Road P.O. Box 345
 Bridgeport, NJ 08014-0345
 Tel: 856-467-4222 Fax: 856-467-5511
 internet: www.caddycorp.com

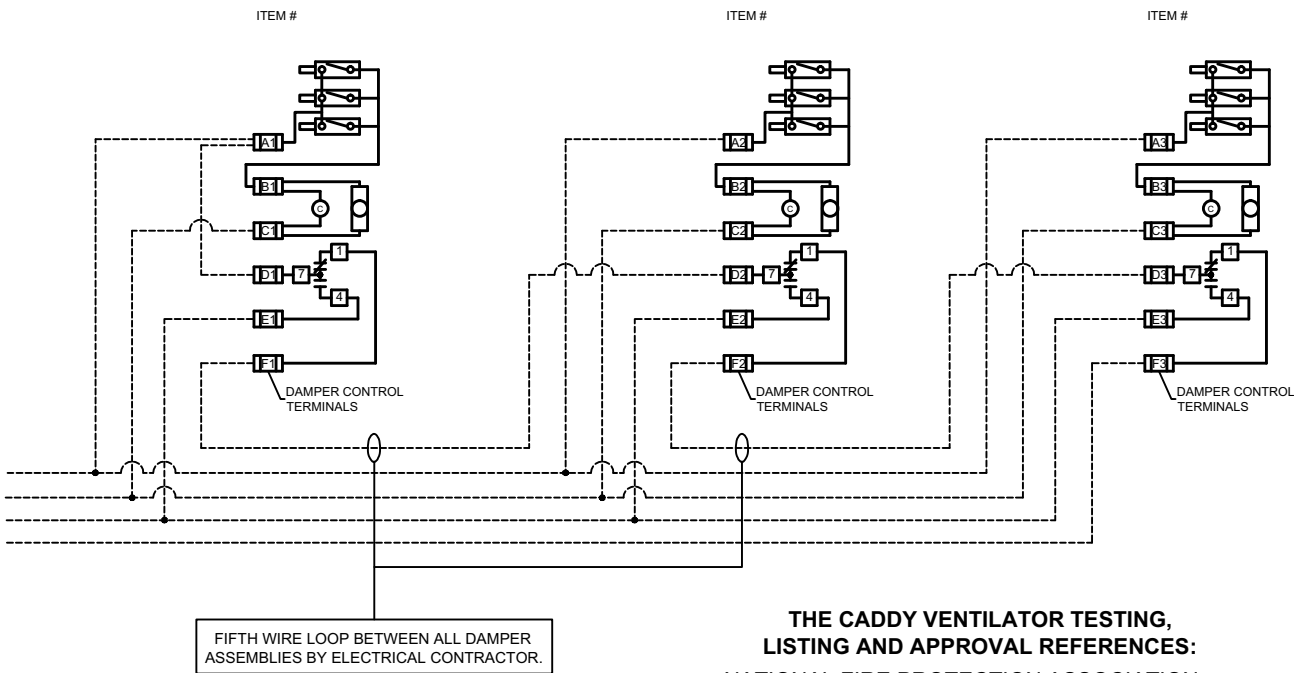

**THE CADDY VENTILATOR TESTING,
LISTING AND APPROVAL REFERENCES:**

- NATIONAL FIRE PROTECTION ASSOCIATION
In Accordance with Recommendation of National Fire Protection Association's NFPA NO. 96 "Vapor Removal From Cooking Equipment"
- NATIONAL SANITATION FOUNDATION
Standard #2 - "Food Service Equipment"
- UNDERWRITERS LABORATORIES, INC
Tested under standard U.L. 710 "Exhaust Hoods for Commercial Cooking Equipment". U.L. Listed under file number MH8215 and MH12264
- UNIFORM MECHANICAL CODE
Section 507 - Commercial Kitchen Hoods and Kitchen Ventilation Systems
- THE BOCA NATIONAL MECHANICAL CODE
Chapter 5 - Kitchen Exhaust Equipment
- STANDARD MECHANICAL CODE (SBCCI)
Section 504 - Commercial Hoods
- UNIFORM BUILDING CODE (ICBO)
- INTERNATIONAL MECHANICAL CODE (IMC) FILE NO. MH82155P



NOTES:

1. Exhaust fan N/O and supply fan N/O terminals are voltage free N/O sets of contacts for use with a remote motor control station.

SEQUENCE OF OPERATIONS

- "FAN ON" - contacts close to start exhaust and supply fans.
- "Wash on" - Contacts open to stop exhaust and supply fans.
- "External fire" (fire switch pulled, fire system discharged) Exhaust fan N/O contacts close to start exhaust fan. Supply fan N/O contacts open to stop supply fan.
- "Internal fire" (ventilator thermostat closure) contacts open to stop exhaust and supply fan.

2. Unit is shipped with a factory installed jumper across exhaust fan disable terminals. With jumper installed "external fire" condition will result in exhaust and supply fan shutdown. Removal of jumper will cause exhaust fan to start, if off, or remain running if on, and supply fan to stop during external fire condition.
3. Alarm com., alarm N/C, alarm N/O-voltage free contacts for connection to building alarm system. Contacts transfer during either internal or external fire mode.
4. Alarm com., alarm N/C, alarm N/O-voltage free contacts for connection to building alarm system. Contacts transfer during either internal or external fire mode. (Optional)
5. Factory installed jumper. Removed jumper and install N/C remote fire switch if required. Pulling switch will initiate external fire mode.
6. Factory installed jumper. Removed jumper and connect to N/C micro switch in Ansul, Kidde, or Pyrochem system. Fire system discharge will initiate external fire mode.

REVISIONS			
REV	DATE	BY	REMARKS

CADDY AirSystems
509 SHARPTOWN ROAD
P.O. BOX 345 BRIDGEPORT NJ 08014
Tel:(856) 467-4222 Fax:(856) 467-5511

EQUIPMENT SCHEDULE

MASTER WIRING DIAGRAM FOR
CPE AND CPE-RP WATER WASH
CONTROL PANELS.

DATE	SCALE	AS NOTED
DR BY	APP'D BY	
DRA		

DWG#

SHT 1
OF 1

CADDY CORPORATION
509 Sharptown Road P.O. Box 345
Bridgeport, NJ 08014-0345
Tel: 856-467-4222 Fax: 856-467-5511
internet: www.caddycorp.com



CADDY CORPORATION

Food Service Equipment

Air Systems

Commercial Kitchen Exhaust Systems

Model CH

Condensate Style

CADDY Air Systems

Model CH-C-W Condensate Ventilator

ITEM NO:

PROJECT:

LOCATION:

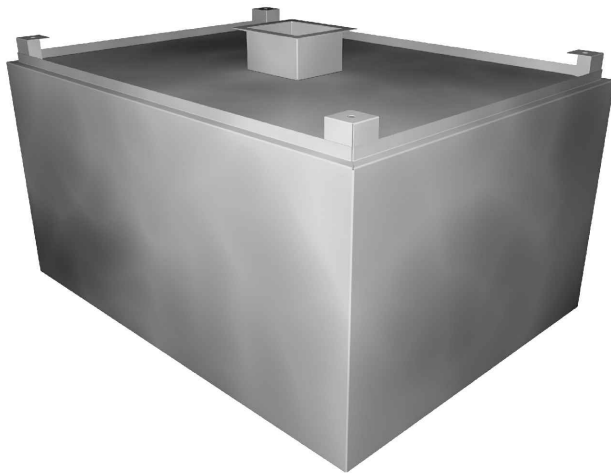

General Specifications

Furnish CADDY *AirSystems* Exhaust Hood Model **CH-C-W** as shown on the plans and as described in the following specifications.

General

Condensate hood shall be constructed of 18 gauge type 300 series stainless steel with all exposed surfaces a number 4 finish. Hood shall be equipped with a sliding damper assembly located at the exhaust duct collar. Hood to be standard equipped with a full perimeter gutter with 1/2" stainless steel drain coupling and 2" high exhaust duct collar. Exhaust volume, duct collar size and static pressure drop shall be as indicated on the plans. Hood to meet all requirements of NSF Standard Number 2.

Description

The CADDY *AirSystems* Model "CH" Condensate Hood is a Type II hood designed to extract moisture from the airstream. This style of ventilator is typically mounted over dishwashers, potwashers, steam tables, bain maries, etc. The hood is fabricated of 18 gauge type 304 stainless steel throughout, with a No. 4 finish.

These units are available in lengths of up to 14'-0" long in a single section.

The exhaust volume required to properly ventilate the steam generated under this hood varies as a function of the steam equipment located beneath the hood. Therefore, the CH-C-I Series is available in three standard air volumes:

150 CFM per lineal ft. for light duty application □ 0.25" S.P.

250 CFM per lineal ft. for medium duty application □ 0.30" S.P.

300 CFM per lineal ft. for heavy duty application □ 0.40" S.P.

Specify the desired air volume per lineal ft.

The CADDY *AirSystems* Model "CH-C-W" Condensate Hood is available for other special applications. Consult with factory.

Features

- All Stainless Steel Construction
- Full Perimeter Gutter With Drain
- Sliding Damper
- Built In Accordance With NSF Standard No. 2
- Light Fixtures (Optional)
- Make-up Air (Optional)

Optional Equipment

- To include 100 Watt incandescent light fixtures
- To include 150 Watt recessed incandescent light fixtures
- To include 80 Watt double tube recessed fluorescent light fixtures
- To include balancing damper
- To include make-up air plenum (Consult factory for options)

 **CADDY CORPORATION**
509 Sharptown Road P.O. Box 345
Bridgeport, NJ 08014-0345
Tel: 856-467-4222 Fax: 856-467-5511
internet: www.caddycorp.com



MODEL:

CH-C-W - - -

ADD THE OVERALL LENGTH (IN INCHES) OF THE VENTILATOR AFTER MODEL DESIGNATION

DAMPER TYPE
ND - NO DAMPER
SD - SLIDING DAMPER

ADD THE OVERALL WIDTH (IN INCHES) OF THE VENTILATOR AFTER MODEL DESIGNATION

STANDARD LIGHT FIXTURES
 100 WATT INCANDESCENT
 RECESSED INCANDESCENT
 RECESSED FLUORESCENT
 (IF RECESSED FLUORESCENT SPECIFY SIZE)

CONSULT FACTORY FOR NON-STANDARD HEIGHTS

ITEM # _____
 EST. WEIGHT _____
 LENGTH _____
 WIDTH _____
 HEIGHT _____
 EXHAUST-CFM _____
 DUCT SIZE _____
 S.P. _____

EXHAUST DUCT COLLAR LOCATED IN CENTER OR AT ANY POINT ALONG LENGTH OF THE HOOD

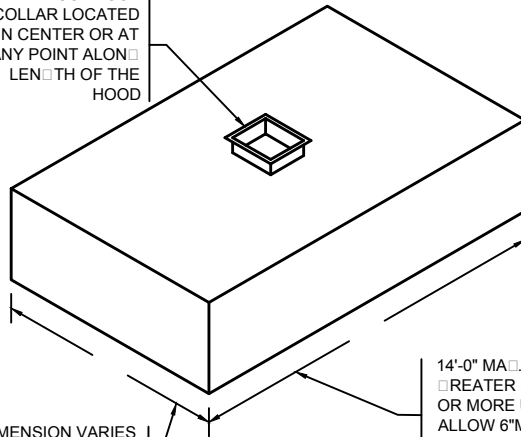

14'-0" MAX. UNIT LENGTH. FOR GREATER LENGTH, JOIN TWO OR MORE UNITS TOGETHER. ALLOW 6" MIN. OVERHANG AT EACH END.

DIMENSION VARIES WITH DEPTH OF THE EQUIPMENT AND REQUIRED OVERHANG

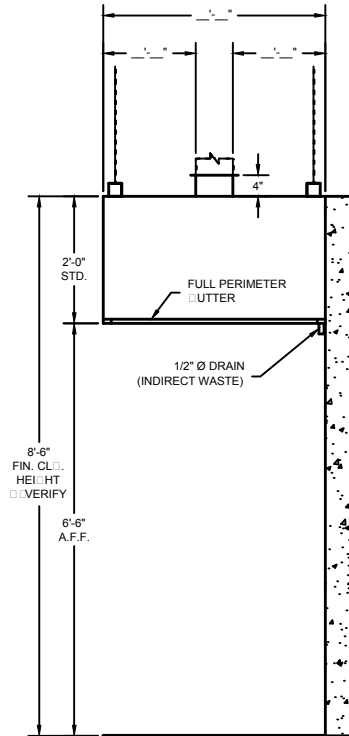

SECTION A-A

DRAWINGS NOT TO SCALE

ENGINEERING DATA

Ventilator Length

Maximum ventilator length in a single section is 14'-0". For lengths greater than 14'-0", join two or more sections. Verify access conditions into building and kitchen space prior to length selection.

Ventilator Hanging Weight

Wt./ lineal ft. Lbs. 55

NOTE: Refer to **CADDY AirSystems**

Master Engineering Data Sheet in engineering data section for determining light, medium, and heavy duty cooking equipment, C.F.M. requirements (exhaust and supply), duct collar sizes and static pressure requirements.

Electrical Requirements

None

Mechanical Requirements

The volume of exhaust required is a function of the type of cooking equipment served by the ventilator, and the type and volume of product cooked. Refer to the **CADDY AirSystems**

Master Engineering Data Chart to determine exhaust volume, duct collar sizes, static pressure drop.



Model CH-C-W-B Condensate Ventilator

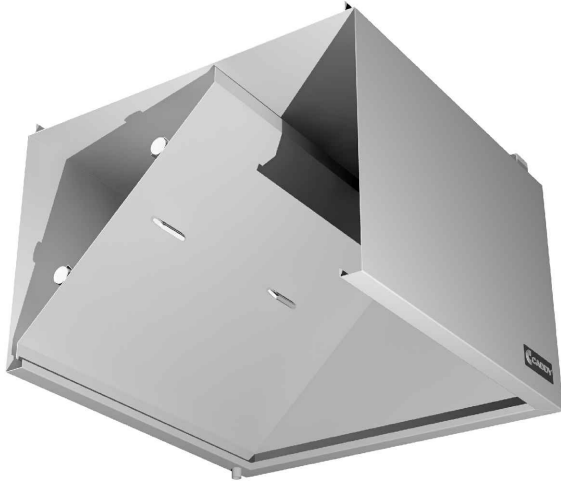
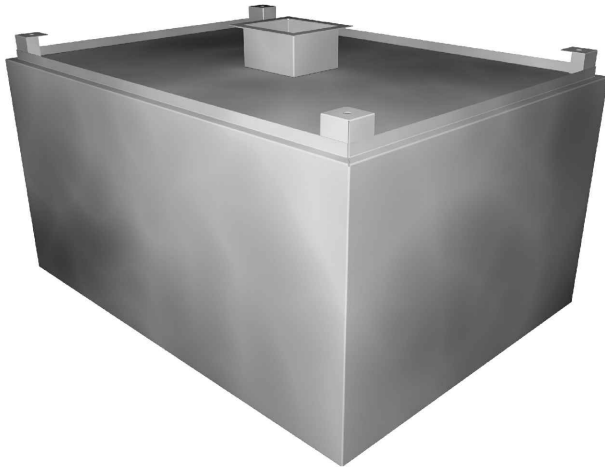

General Specifications

Furnish CADDY *AirSystems* Exhaust Hood Model **CH-C-W-B** as shown on the plans and as described in the following specifications.

General

Condensate hood shall be constructed of 18 gauge type 304, number 4 finish and contain full length condensate baffles for condensing and extracting moisture from the airstream. Baffles are designed to remove steam effectively along the entire length of the hood. Hood to be standard equipped with a full perimeter gutter with 1/2" stainless steel drain coupling and 2" high exhaust duct collar. Exhaust volume, duct collar size and static pressure drop shall be as indicated on the plans. Hood to meet all requirements of NSF Standard Number 2.

Optional Equipment

- To include 100 Watt incandescent light fixtures
- To include 150 Watt recessed incandescent light fixtures
- To include 80 Watt double tube recessed fluorescent light fixtures
- To include balancing damper
- To include make-up air plenum (Consult factory for options)

Description

The CADDY *AirSystems* Model "CH" Condensate Hood is a Type II hood designed to condense and extract moisture from the airstream. This style of ventilator is typically mounted over dishwashers, potwashers, steam tables, bain maries, etc. The hood is fabricated of 18 gauge type 304 stainless steel throughout, with a No. 4 finish.

These units are available in lengths of up to 14'-0" long in a single section.

The exhaust volume required to properly ventilate the steam generated under this hood varies as a function of the steam equipment located beneath the hood. Therefore, the CH-C-I-B Series is available in three standard air volumes:

150 CFM per lineal ft. for light duty application □ 0.25"

S.P.

250 CFM per lineal ft. for medium duty application □ 0.30"

S.P.

300 CFM per lineal ft. for heavy duty application □ 0.40"

S.P.

Specify the desired air volume per lineal ft.

The condensing baffles run the full length of the hood and are designed to form high velocity inlet slots. Full-length high velocity inlet slots provide exceptional steam removal performance over the entire length of the hood.

The CADDY *AirSystems* Model "CH-C-W-B" Condensate Hood is available for other special applications. Consult with factory.

Features

- All Stainless Steel Construction
- Full Perimeter □utter With Drain
- Full length Removable Condensate Baffles
- Built In Accordance With NSF Standard No. 2
- Light Fixtures (Optional)
- Sliding Damper (Optional)
- Make-up Air (Optional)



MODEL:

CH-C-W-B - - -

ADD THE OVERALL LENGTH (IN INCHES) OF THE VENTILATOR AFTER MODEL DESIGNATION

DAMPER TYPE
ND - NO DAMPER
SD - SLIDING DAMPER

ADD THE OVERALL WIDTH (IN INCHES) OF THE VENTILATOR AFTER MODEL DESIGNATION

STANDARD LIGHT FIXTURES
 100 WATT INCANDESCENT
 RECESSED INCANDESCENT
 RECESSED FLUORESCENT
 (IF RECESSED FLUORESCENT SPECIFY SIZE)

CONSULT FACTORY FOR NON-STANDARD HEIGHTS

ITEM # _____
 EST. WEIGHT _____
 LENGTH _____
 WIDTH _____
 HEIGHT _____
 EXHAUST-CFM _____
 DUCT SIZE _____
 S.P. _____

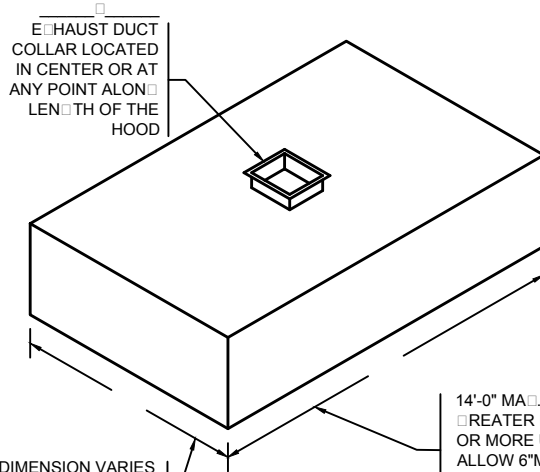

14'-0" MAX. UNIT LENGTH. FOR GREATER LENGTH, JOIN TWO OR MORE UNITS TOGETHER. ALLOW 6" MIN. OVERHANG AT EACH END.

DIMENSION VARIES WITH DEPTH OF THE EQUIPMENT AND REQUIRED OVERHANG

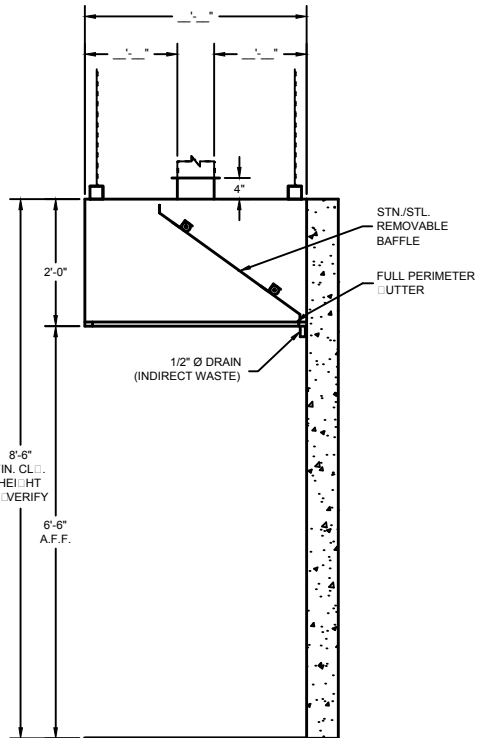

SECTION C-C

DRAWINGS NOT TO SCALE

ENGINEERING DATA

Ventilator Length

Maximum ventilator length in a single section is 14'-0". For lengths greater than 14'-0", join two or more sections. Verify access conditions into building and kitchen space prior to length selection.

Ventilator Hanging Weight

Wt./lineal ft. Lbs. 55

NOTE: Refer to CADDY AirSystems

Master Engineering Data Sheet in engineering data section for determining light, medium, and heavy duty cooking equipment, C.F.M. requirements (exhaust and supply), duct collar sizes and static pressure requirements.

Electrical Requirements

None

Mechanical Requirements

The volume of exhaust required is a function of the type of cooking equipment served by the ventilator, and the type and volume of product cooked. Refer to the **CADDY AirSystems**

Master Engineering Data Chart to determine exhaust volume, duct collar sizes, static pressure drop.





CADDY CORPORATION

Food Service Equipment

Air Systems

Utility Distribution Systems



General Specifications

Caddy Corporation of America Energy Distribution and Management System, which shall be (select one).

- | | |
|-----------------------------------|------------------------------------|
| <input type="checkbox"/> Island | <input type="checkbox"/> Ceiling |
| <input type="checkbox"/> Wall | <input type="checkbox"/> Counter |
| <input type="checkbox"/> Conveyor | <input type="checkbox"/> Interlink |

mounted, pre-wired (pre-plumbed) to one final connection point for (select any of the following)

- | | | |
|------------------------------------|--|---|
| <input type="checkbox"/> Electric | <input type="checkbox"/> Cold Water | <input type="checkbox"/> Compressed Air |
| <input type="checkbox"/> Gas | <input type="checkbox"/> Steam | <input type="checkbox"/> Filter Water |
| <input type="checkbox"/> Hot Water | <input type="checkbox"/> Condensate Return | |

service, to support the following equipment items as shown on drawing or architectural plan:

ITEM NOS: _____

Compliance:

System to be by Underwriters Laboratories (U.L.) Listed Utility Distribution System (wet location) or Commercial Appliance Outlet Centers (dry location), as a complete system manufactured in accordance with the latest edition of NEC, NFPA Pamphlet NO. 96 and No. 54, ANSI, ASME, Uniform Plumbing Code, NEMA, and OSHA using only Underwriters Laboratories tested, Bureau of Mines rated I.A.P.M.O. and A.G.A. certified components. System shall be in compliance with N.S.F. standards and local building codes.

Construction:

The Caddy System shall be _____ ft x _____ in. long. Completely modular with fixed but removable riser and pedestal sections. End caps and exterior panels shall be constructed of #16 gauge Type No 304 stainless steel with a No 4 mill finish, and all removable riser and pedestal panels shall be constructed of #18 gauge stainless steel. The pedestal shall be secured to the floor with unexposed stainless steel angle interior reinforcing flange. The plumbing compartment shall be isolated and weatherproof sealed from the electrical compartment by a #16 gauge stainless steel divider. When system is specified for in a wet location all electrical access panels, doors and field joints shall be fully sealed or gasketed. All electrical compartments shall be NEMA Type 4 or NEMA 12 enclosures, and all receptacles, switches and circuit breakers shall be provided with a weatherproof cover compatible with and covering the accessible portion of the receptacle face, switch actuator, and circuit breaker actuator.

(Continue specifications selecting as required)

- Ceiling mounted system shall be suspended by risers with unexposed stainless steel angle. Final Attachment to overhead support (not by Caddy) to be done with 3/8" steel rods (not by Caddy). Straight drop cord to be furnish with either straight blade or twist lock female connector body.
- Island (or Wall) mounted system shall be provided with neoprene bumper strips and a 6" peak top.

Electrical:

Main electrical feeders in system shall be four conductor solid copper bus bars having balanced loads and phases with branch circuit locations directly behind each connection plat. Bus bars shall be of capacity for full load the entire length of system, mounted on non-conductive insulators spaced 14" to 24" centers, equipped with solid copper connection lugs for main service and system equipment ground. Field joints shall be connected by securing bolts in each bus bar through pre drilled holes. Branch circuit wiring for each electrical connection shall be phase identified and sized according to the circuit breaker rated ampacity.

Safety and Control:

Furnish a Caddy #16 gauge stainless steel gasketed connection plate for each electrical connection, equipped with point-of-use circuit breaker with knob-type watertight actuator and pilot light. On each connection plate furnish a Caddy U.L. tested adjustable trip, 24-volt power sensitive ground fault sensor and relay, which can be adjusted by maintenance personnel in order to eliminate any nuisance tripping should it ever occur. Regardless of voltage, amperage or phase, the equipment connected to the Caddy system which might develop an internal current leakage to ground, or power supply, not detectable by the circuit breaker, will be automatically disconnected from its power source without affecting the operation of any other connected equipment. A ground fault test button shall be provided on each plate to check for proper operation of the device. Connection plate shall be individually grounded to system main frame and shall be equipped with a grounding type receptacle having a specific NEMA polarized configuration. Each connection plate assembly shall bear the U.L. label as having met Underwriters Laboratories branch circuit requirements for voltages up to and including 480 volts.

Furnish Fire-Fuel Shut-Off for (electric) (gas) service for individual pieces of equipment per NFPA No. 96 Gas solenoid valve shall be equipped with a 5-second delay to eliminate instantaneous power interruptions from causing nuisance pilot outages. Shut-Off system shall be pre-wired and pre-plumbed in Caddy system, needing only one final connection by electrical contractor from 120 volt power source in fire extinguishing system relay or micro-switch. Caddy to furnish manual resets for gas and electrical using no external solenoid valves, contactors, relays or shunt trips.

Plates shall be spaced on 12" centers and have a quick-connect and quick-disconnect means for separating each ground fault device, fire-fuel shut-off and all control wiring from the Caddy system to facilitate changing of connection plates for future additions, deletions or changes of equipment. Furnish _____ blank plates for future equipment. Furnish Caddy U.L. tested matching Special Purpose Power Supply Cord and Plug Set for each



(Continue specifications selecting as required)

connection plate; 125 volt and 250 volt cord sets over 60 amperes and all 480 volt cord sets shall be shielded and non-arcing type. All cords shall be supplied with strain relief grips an the equipment connecting end.

Furnish control panel mounted in each end cap of Island mounted system which shall include a duplex convenience outlet with circuit breaker and equipment status indicator lights numerically coded to indicator lights on each connection plate to show power. A control panel shall also house the following controls, if required by specifier :

Gas fire-fuel shut-off with delay, warning light and solid state whistle

Ventilator light switch with circuit breaker

Exhaust fan switch

Ventilator control panel

Main circuit breaker for systems under 500 Amps

Furnish a System Disconnect Switch which shall shut down the electrical power to all of the equipment on line without the need for accessing the main circuit breaker panel which is generally remote to the Caddy system.

No live electrical parts or wiring in panels shall be accessible unless panels are removed requiring the use of security keys or tools. Permanently lettered metallic labels showing operational procedures and markings in accordance with Underwriters Laboratories, shall be furnished as part of this system.

Plumbing:

Furnish direct reading combination pressure temperature gauges for incoming services for steam supply, hot water, cold water, and chilled water. Furnish quarter turn steel ball type shut-off valves for gas and water main incoming services, and for gas, steam supply and condensate return branch piping outlets. To permit easy cleaning a non-combustible, glass-smooth, color coded plastic coating is to be applied to each gas, steam and water hose supplied with the Caddy system. All piping and disconnects shall be color coded.

(Continue specifications, indicating applicable service)

HOT AND COLD WATER

Piping shall be hard temper type "L" copper tubing with copper sweat type solder fittings, wrapped with 1/8" thermal closed cell piping insulation. Each branch outlet shall be furnished with a safe-tested, fully adjustable connector assembly consisting of a stainless steel closed-pitch corrugated hose and stainless steel braided restraining chain, complete with a solid brass two-way quick-disconnect device for instant removal. Furnish _____ capped NPT branch outlets for future equipment connections.

GAS

Piping shall be black iron with welded threadlets to branch connection and drip tee on service riser. Each branch outlet shall be furnished with a connector assembly consisting of a

fully adjustable stainless steel corrugated hose and stainless steel braided restraining chain, complete with a solid brass quick-disconnect device for instant removal. Connector assembly shall be certified to ANSI-Z-21.24, Metal Connectors for Gas Appliances, and ANSI-Z-21.69, Connectors for Movable Gas Appliances. Furnish _____ capped NPT branch outlets for future equipment connections.

STEAM SUPPLY AND CONDENSATE RETURN

Piping shall be black iron with welded threadlets to branch connection and service risers. All steam lines shall be wrapped with 1/8" fiberglass insulation tape (no asbestos). Each branch outlet shall be furnished with a safe-tested, fully adjustable connector assembly consisting of a stainless steel closed-pitch corrugated hose and stainless steel braided restraining chain and a overbraid heat shield (no asbestos). Furnish _____ capped NPT branch outlets for future equipment connections.

Steam piping shall include internal continuous steam purging system consisting of a quarter turn ball type inlet valve, Y-strainer with blow-down valve, trap, check valve and quarter turn ball-type outlet valve. Steam service supply pipe shall be fitted with a Caddy (remote) (integral) motorized steam valve (installed on nearest service branch tee or at boiler by H.C.). A seven-day 24-hour sequential timer having an automatic 12-hour rewind for remote steam valve shall be mounted in Caddy system at factory. All line strainers shall be a two-minute automatic blowdown to prevent clogging by mineral deposits.

Submittal Requirements:

At the time of submittal, in order to receive approval manufacturer must supply a copy of their U.L. Test Report and U.L. Listing Card to show compliance with the electric and plumbing services as required in this project, in addition to U.L. Cards for Ground Fault Sensing and Relaying Equipment, Panelboard Accessories (connection plate assembly), and Cord Sets and Power Supply Cords.

Upon request of specifier, manufacturer must submit samples, drawings and diagrams of the following system assemblies for evaluation and approval prior to the equipment contractor preparing his submittal:

U.L. tested interchangeable connection plate assembly complete with circuit breaker and knob-type watertight actuator, adjustable trip 24-volt ground fault sensor and relay, 24-volt fire-fuel shut-off mechanism, NEMA configuration outlet, 24-volt dual-color LED status indicator light and test button; 5-second gas fire-fuel shut-off delay; internal continuous steam purging system;; A.G.A. gas hose connector certified to ANSI-Z-21.69.

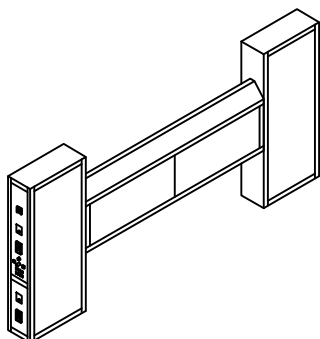

FEATURES OF SERIES ID:

- Cantilever supports
- Digital water meters
- Energy saving controls for electric, gas, steam and water
- Equipment cord and plug assemblies
- Fire-fuel interrupters
- Gas shut-off with delay
- Ground fault branch circuit protection
- Hose reels
- Interchangeable connection plates
- Low-level detergent indicator
- Low-voltage control wiring
- Magnetic motor controllers
- Main service shut-offs
- Malfunction alarms
- Modular construction
- Motorized valves
- Point-of-use circuit breakers
- Pot and kettle fillers
- Quick-disconnect hose assemblies
- Steam purging system
- Temperature-pressure gauges
- Timers for 7 day, 24-hour operation
- Ventilator fan and wash-down controls
- Water conditioning systems
- Waterproof receptacle and switch cover
- Water-wash drain assembly

All Caddy Systems are Underwriters Laboratories (UL) Listed as a complete system manufactured in accordance with the latest edition of NEC, NFPA Pamphlets No. 96 and No. 54, ANSI, ASME, Uniform Plumbing Code, NEMA, and OSHA, using only UL tested, Bureau of Mines rated, I.A.M.P.O. and A.G.A. certified components.

ADVANTAGES:

- The electrical contractor need only bring the main electric service to the Caddy system, which contains the circuit breakers for each equipment item at its connection point, thus eliminating a panel of circuit breakers and the contractor's job is simplified.
- The plumbing contractor connects the gas, steam and water services to the Caddy system, and each equipment item is plugged directly into the system in a matter of minutes.
- By eliminating wires and piping traditionally buried in the walls and the floors, the overall cost to the owner is reduced and the additional benefits allow for ease of cleaning, service and repairs, rearranging and adding equipment in the future.
- Jobs can be bid more accurately. No "unknown field conditions" to be considered.
- All necessary parts and controls are supplied from one source... Caddy Corporation.

General notes:

- Maximum length for raceway is 14'-6" before a filed joint is added.
- Minimum riser depth from end is 24" when ventilator controls are specified, and 18" when more than two services from overhead are in the same riser.
- Minimum riser depth from end is 18" when more than two services from floor are in same riser.
- Electrical systems without plumbing can be 6" wide.
- Electrical point-of-use connection plates are located on 12" centers
- Services from above are recommended to avoid critical fields service locations.

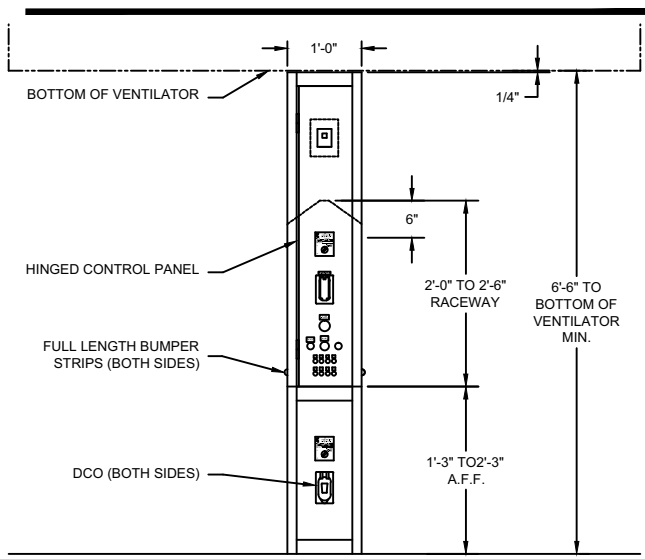
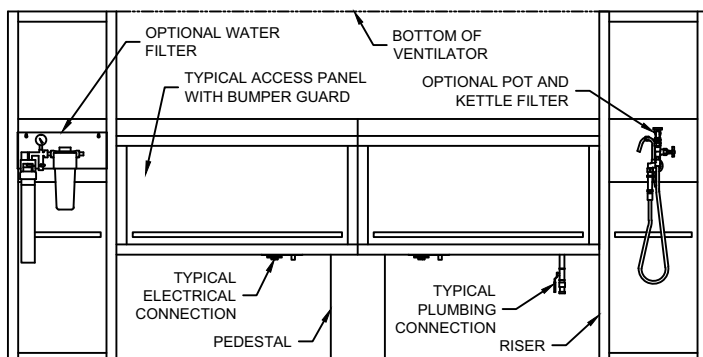



WALL MOUNTED

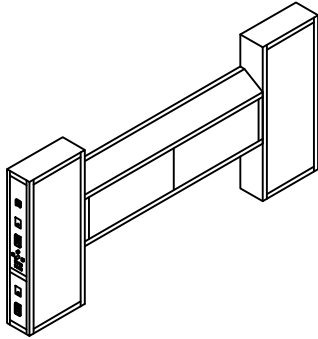

FEATURES OF SERIES WL:

- Cantilever supports
- Digital water meters
- Energy saving controls for electric, gas, steam and water
- Equipment cord and plug assemblies
- Fire-fuel interrupters
- Gas shut-off with delay
- Ground fault branch circuit protection
- Hose reels
- Interchangeable connection plates
- Low-level detergent indicator
- Low-voltage control wiring
- Magnetic motor controllers
- Main service shut-offs
- Malfunction alarms
- Modular construction
- Motorized valves
- Point-of-use circuit breakers
- Pot and kettle fillers
- Quick-disconnect hose assemblies
- Steam purging system
- Temperature-pressure gauges
- Timers for 7 day, 24-hour operation
- Ventilator fan and wash-down controls
- Water conditioning systems
- Waterproof receptacle and switch cover
- Water-wash drain assembly

All Caddy Systems are Underwriters Laboratories (UL) Listed as a complete system manufactured in accordance with the latest edition of NEC, NFPA Pamphlets No. 96 and No. 54, ANSI, ASME, Uniform Plumbing Code, NEMA, and OSHA, using only UL tested, Bureau of Mines rated, I.A.M.P.O. and A.G.A. certified components.

ADVANTAGES:

- The electrical contractor need only bring the main electric service to the Caddy system, which contains the circuit breakers for each equipment item at its connection point, thus eliminating a panel of circuit breakers and the contractor's job is simplified.
- The plumbing contractor connects the gas, steam and water services to the Caddy system, and each equipment item is plugged directly into the system in a matter of minutes.
- By eliminating wires and piping traditionally buried in the walls and the floors, the overall cost to the owner is reduced and the additional benefits allow for ease of cleaning, service and repairs, rearranging and adding equipment in the future.
- Jobs can be bid more accurately. No "unknown field conditions" to be considered.
- All necessary parts and controls are supplied from one source... Caddy Corporation.

General notes:

- Maximum length for raceway is 14'-6" before a filed joint is added.
- Minimum riser depth from end is 24" when ventilator controls are specified, and 18" when more than two services from overhead are in the same riser.
- Minimum riser depth from end is 18" when more than two services from floor are in same riser.
- Electrical systems without plumbing can be 6" wide.
- Electrical point-of-use connection plates are located on 12" centers 18" centers when plumbing and electric is specified.
- Services from above are recommended to avoid critical fields service locations.

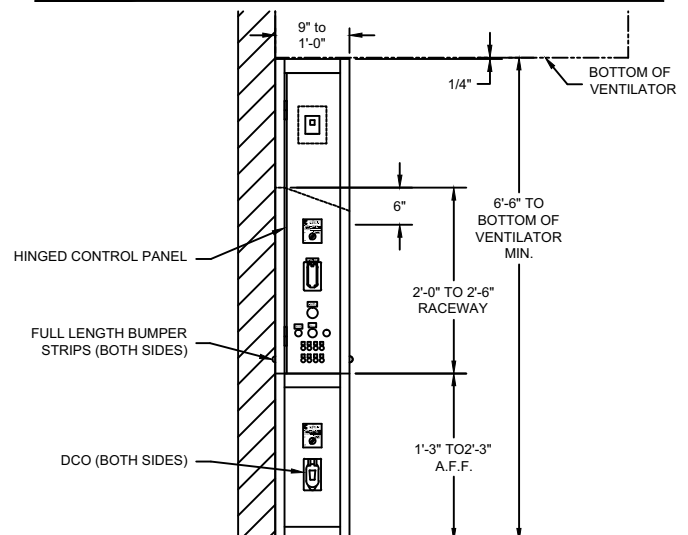
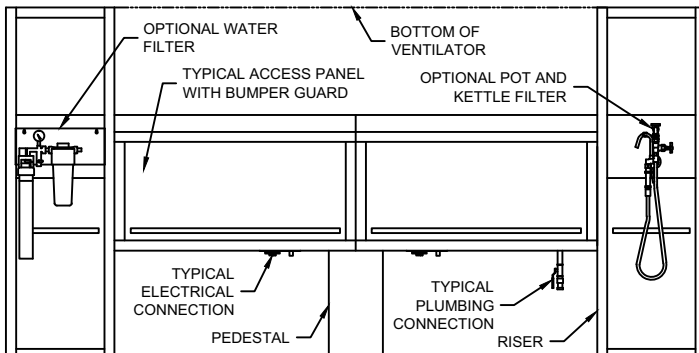

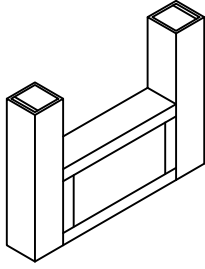

FEATURES OF SERIES OD:

- Energy saving controls for electric, gas, steam and water
- Equipment cord and plug assemblies
- Fire-fuel interrupters
- Ground fault branch circuit protection
- Integral lighting
- Interchangeable connection plates
- Low-voltage control wiring
- Magnetic motor controllers
- Main service shut-offs
- Malfunction alarms
- Modular construction
- Point-of-use circuit breakers
- Quick-disconnect hose assemblies
- Timers for 7 day, 24-hour operation
- Ventilator fan and wash-down controls
- Waterproof receptacle and switch cover

All Caddy Systems are Underwriters Laboratories (UL) Listed as a complete system manufactured in accordance with the latest edition of NEC, NFPA Pamphlets No. 96 and No. 54, ANSI, ASME, Uniform Plumbing Code, NEMA, and OSHA, using only UL tested, Bureau of Mines rated, I.A.M.P.O. and A.G.A. certified components.

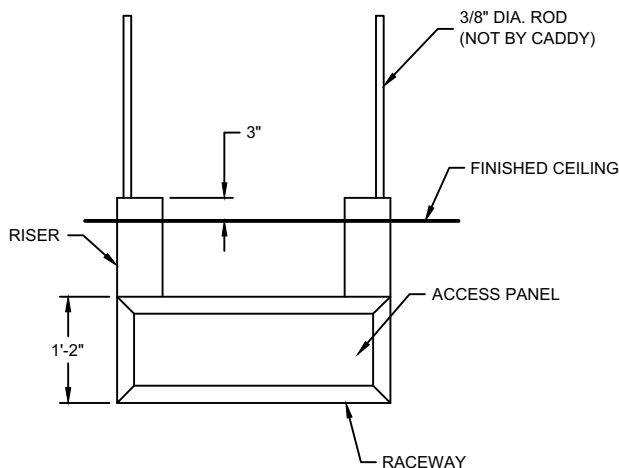

ADVANTAGES:

- The electrical contractor need only bring the main electric service to the Caddy system, which contains the circuit breakers for each equipment item at its connection point, thus eliminating a panel of circuit breakers and the contractor's job is simplified.
- The plumbing contractor connects the water services to the Caddy system, and each equipment item is plugged directly into the system in a matter of minutes.
- By eliminating wires and piping traditionally buried in the walls and the floors, the overall cost to the owner is reduced and the additional benefits allow for ease of cleaning, service and repairs, rearranging and adding equipment in the future.
- Jobs can be bid more accurately. No "unknown field conditions" to be considered.
- All necessary parts and controls are supplied from one source... Caddy Corporation.

General notes:

- Maximum length for raceway is 14'-6" before a filed joint is added.
- Minimum riser depth from end is 24" when ventilator controls are specified, and 18" when more than two services from overhead are in the same riser.
- Minimum riser depth from end is 18" when more than two services from floor are in same riser.
- Electrical systems without plumbing can be 6" wide.
- Electrical point-of-use connection plates are located on 12" centers.
- Extension cords, drop cords and coil cords may be specified.
- Coil cords are available only in 125/1 ϕ and 250/1 ϕ 3-wire, 20-amps or less.

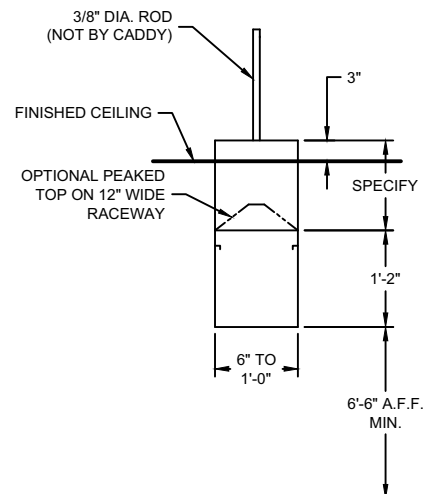

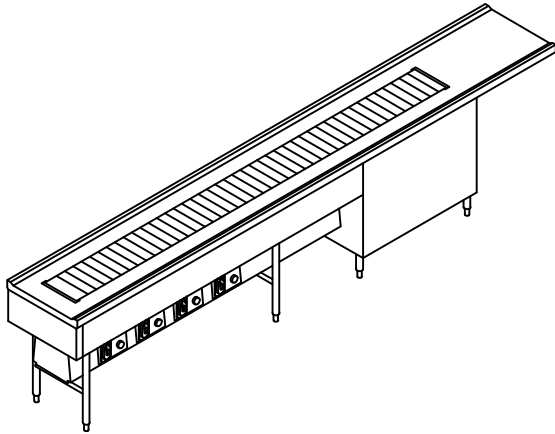

FEATURES OF SERIES TS:

- Energy saving controls for electric, gas, steam and water
- Equipment cord and plug assemblies
- Fire-fuel interrupters
- Gas shut-off with delay
- Ground fault branch circuit protection
- Interchangeable connection plates
- Low-voltage control wiring
- Magnetic motor controllers
- Main service shut-offs
- Malfunction alarms
- Point-of-use circuit breakers
- Quick-disconnect hose assemblies
- Timers for 7 day, 24-hour operation
- Ventilator fan and wash-down controls
- Waterproof receptacle and switch cover

All Caddy Systems are Underwriters Laboratories (UL) Listed as a complete system manufactured in accordance with the latest edition of NEC, NFPA Pamphlets No. 96 and No. 54, ANSI, ASME, Uniform Plumbing Code, NEMA, and OSHA, using only UL tested, Bureau of Mines rated, I.A.M.P.O. and A.G.A. certified components.

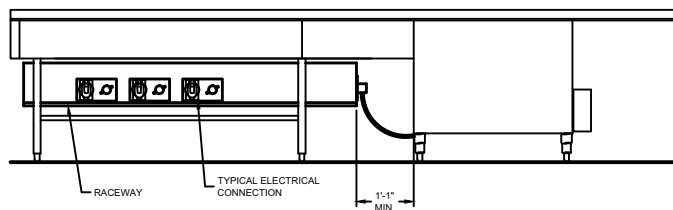

ADVANTAGES:

- The electrical contractor need only bring the main electric service to the Caddy system, which contains the circuit breakers for each equipment item at its connection point, thus eliminating a panel of circuit breakers and the contractor's job is simplified.
- The plumbing contractor connects the gas, steam and water services to the Caddy system, and each equipment item is plugged directly into the system in a matter of minutes.
- By eliminating wires and piping traditionally buried in the walls and the floors, the overall cost to the owner is reduced and the additional benefits allow for ease of cleaning, service and repairs, rearranging and adding equipment in the future.
- Jobs can be bid more accurately. No "unknown field conditions" to be considered.
- All necessary parts and controls are supplied from one source... Caddy Corporation.

General notes:

- Maximum length for raceway is 14'-6" before a filed joint is added.
- Minimum riser depth from end is 24" when ventilator controls are specified, and 18" when more than two services from overhead are in the same riser.
- Minimum riser depth from end is 18" when more than two services from floor are in same riser.
- Electrical systems without plumbing can be 6" wide.
- Electrical point-of-use connection plates are located on 12" centers
- Services from above are recommended to avoid critical fields service locations.

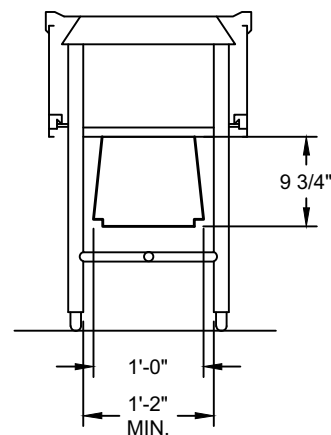



CADDY CORPORATION

Food Service Equipment

Air Systems

Soiled Tray
Conveyor
Systems



SOILED TRAY CONVEYOR CF-10 SERIES

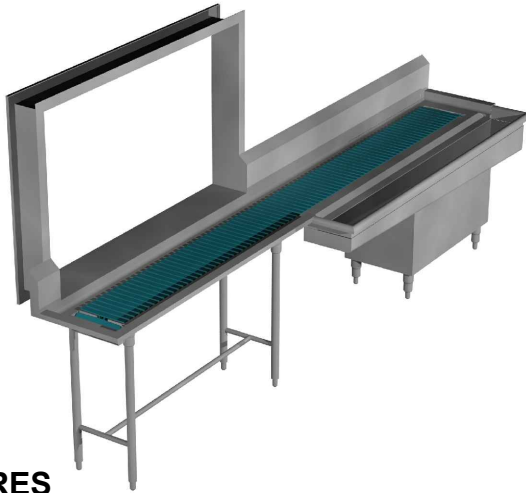

FEATURES

- Multi-directional straight or curved level, incline or decline
- Transports various objects and sizes

SPECIFICATIONS:

Series CF-10 Soiled tray conveyor to be as manufactured by Caddy Corporation. U.L. and N.S.F. listed with labels affixed. Unit shall be as detailed on the plan and to accommodate up to 16" wide trays. Other size trays can be accommodated upon request. (Specify dimensions of item to be used.)

Conveyor belt to consist of a stainless steel chain having approximately 3/4" pitch with 10" side snap-on type slats. Slats to have tapered edges on all sides and molded of low friction polycarbonate compound and replaceable without the use of special tools and disassembling of belt chain. The assembled belt to allow multi-directional installation. Slats not to overlap in any position to provide effective access of cleaning agents to all parts of the assembled belt and conveyor bed.

Conveyor bed to be 14 gauge stainless steel bed with longitudinal intersections rounded on 3/4" radius. Joints to be of welded construction, ground and polished to a uniform #4 finish. Stainless steel channel cross braces on approximately 5'-0" centers to be provided supporting the bed and to the monorail belt return tracking system. Conveyor belt to ride in a recessed track allowing continuous drainage of conveyor bed.

Curved section(s) to have positive hold-down tracks made of nonmetallic material at least 1/2" thick with built-in solid lubricant for continuous lubrication of belts. Materials that transmit heat due to high friction and resistance are not acceptable. Belt capable of movement through a turn of 22" radius to the center of the conveyor. (Other radii available upon request.)

Intermediate supports of the conveyor to consist of 1 5/8" O.D. stainless steel "H" frame legs with 1" O.D. stainless steel cross bracing completely welded, finished and provided with adjustable stainless steel bullet shaped feet. (Flanged feet also available).

Drive housing to consist of 18 gauge stainless steel enclosure on two sides with removable rear panel and opposite hinged access door with full height pull.

Frame of drive housing to be 2" x 2" angles stainless steel superstructure and to set on 6-1/2" high adjustable stainless steel feet.

Drive assembly to be at discharge end. D.C. controller to be solid state SCR type with built-in electronic torque control and infinite variable speed from zero to 40 feet per minute. Maximum chain pull not to exceed 250 lbs. at any point on conveyor. Conveyor chain to be driven by reduction gearhead wash down type D.C. motor to eliminate high torque in case of jamming condition of the conveyor. Motor can also be held in locked rotor position without damage to conveyor. Motor to be controlled manually by an on/off switch and automatically through a limit switch as required by application. All wired to the watertight SCR solid state D.C. controller with overload protection, in NEMA 4 type enclosure.

BWF belt washer to consist of welded 16 gauge stainless steel. Belt washer to have top and bottom fan shaped sprays arranged so lukewarm water thoroughly washes all belt surfaces after which belt is wiped continuously. Belt washer to have hinged drop-down, splash proof stainless steel access door. Washer to be fitted with interconnected water pressure reducing valve, water pressure gauge, shutoff valve and thermostatically controlled mixing valve with check valves. Bottom of belt washer to have 1 1/2" drain with tailpiece and two removable stainless steel perforated scrap baskets. Belt washer piping to be complete with approved type vacuum breaker and check valve. All piping exposed to view to be chrome plated.

Skirting to consist of 18 gauge stainless steel pan type panels with welded corners.

Conveyor to be furnished with an 18 gauge stainless steel catch pan under full length of conveyor. Catch pan to be pitched towards belt washer.

(Continue specifications for conveyor in excess of 20'-0" long)

Intermediate Drain

Catch pan(s) also to be pitched to intermediate swill sink(s) measuring approximately 10"x16"x4" deep of stainless steel construction with perforated removable stainless steel scrap basket and 1-1/2" drain with tailpiece.

CF-10 Conveyor Optional Features:

Fixed Speed Requirement

Variable speed control to have locking cover for non-tampering when fixed speed is desired.

CADDY CORPORATION
509 Sharptown Road P.O. Box 345
Bridgeport, NJ 08014-0345
Tel: 856-467-4222 Fax: 856-467-5511
internet: www.caddycorp.com

**SOILED TRAY CONVEYOR
CF-10 SERIES**



Optional Accessories Continue:

Intermediate Drive

Drive assembly(s) to be installed at intermediate location(s) without break in conveyor belt and belt bed.

Automatic Water Saver Control for Fresh Water Belt Washer

Operation of belt washer to be controlled by solenoid valve integrally wired to On/Off switch of conveyor to provide automatic operation of belt washer while conveyor is running. A separate On/Off switch to be provided to permit operation of conveyor without belt washer.

Belt Washer with Recirculating Water

BWR belt washer to consist of welded 16 gauge stainless steel. Belt washer to have top and bottom fan shaped sprays arranged so lukewarm water thoroughly washes all belt surfaces after which belt is wiped continuously. Belt washer to have hinged drop-down, splash proof stainless steel access door. Washer to be fitted with interconnected water pressure reducing valve, water pressure gauge, shutoff valve and thermostatically controlled mixing valve

with check valves. Bottom of belt washer to have 1 1/2" drain with tailpiece and two removable stainless steel perforated scrap baskets, and removable constant overflow standpipe to maintain water level. A pump to be provided to recirculate water from reservoir through spray nozzles. Recirculating system to include a removable filter to facilitate cleaning. Operation of belt washer to be controlled by solenoid valve integrally wired to On/Off switch of conveyor to provide automatic operation of belt washer while conveyor is running. A separate On/Off switch to be provided to permit operation of conveyor without belt washer.

Timed Belt Washing Cycle (for clean-up operations)

Belt washer to be controlled by automatic timer activated by a push button switch inside belt washer housing in such a manner that conveyor and belt washer will operate without interruption for an adjustable cycle of up to 16 minutes. After completion of wash cycle conveyor is ready for next start-up.

Detergent Injector (for maximum sanitation)

A pump type detergent injector working in conjunction with the belt washer water supply to be furnished.

Housings for Drive and Belt Washer

Specifying an intermediate drive (or drives) in your conveyor design provides unlimited options to meet architectural, operational, safety, and efficiency criteria.

U.L. listing of your custom conveyor up to 500 feet long (and more) with one single belt, unbroken by troublesome transfer points, is standard when specified.

The ability to locate the belt washer separately from the drive, if necessary, to accommodate access and sanitary consideration, is an important option.

End Drive With Belt Washer

End Drive Without Belt Washer

Intermediate Drive With Belt Washer

Intermediate Drive Without Belt Washer

Intermediate Belt Washer

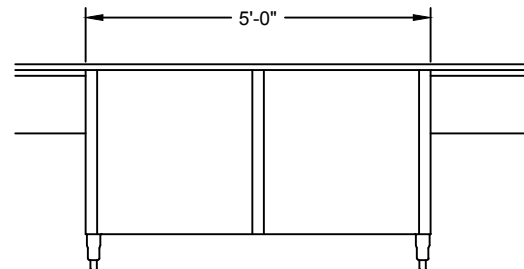
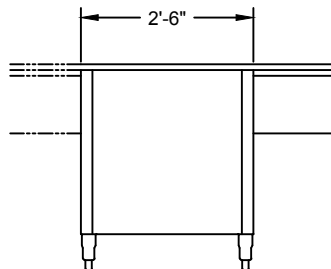
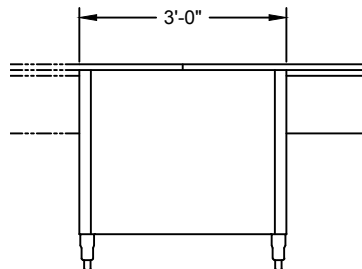

**SOILED TRAY CONVEYOR
CF-10 SERIES**



Optional Accessories Continue:

TYPICAL ROUGHING, PLUMBING AND ELECTRICAL DATA

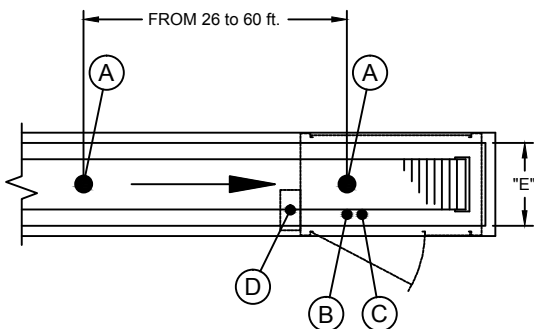

ROUGH-IN SCHEDULE	
NOTE: ALL ROUGH-INS TO BE 4" AFF	
SYM	DESCRIPTION
A	1 1/2" I.P.S. WASTE
B	1/2" I.P.S. HOT WATER
C	1/2" I.P.S. COLD WATER
D	ELECTRICAL CONNECTION

NOTE: All roughings from floor should be stubbed up 4" A.F.F. (All roughings extending from wall should be 10" A.F.F.)

BED WIDTH	
OBJECT TRANSPORTED	"E"
14" □ 18" AND 15" □ 20"	16 1/2"
16" □ 22" AND 16 1/2" □ 22"	18"
20" □ 20"	22"

Conveyors over 20 ft. long require additional drain(s) as determined by application.

ELECTRICAL CHARACTERISTICS

Motors available for 120/60 Hz. single phase up to and including 3/4 hp. Motors 1/2 hp. and 3/4 hp. are also available for 208/220/60 Hz. single phase.

Motor sizes for soiled tray conveyors:

STRAIGHT
1/4 HP up to 25 ft.
1/2 HP 26 to 50 ft.
3/4 HP 51 to 75 ft.

U-SHAPED
1/2 HP up to 25 ft.
3/4 HP 26 to 40 ft.

L-SHAPED ONE 90° TURN
1/4 HP up to 20 ft.
1/2 HP up to 39ft.
3/4 HP up to 56 ft.

2 TURNS
1/2 HP up to 25 ft.
3/4 HP 26 to 40 ft.

Consult factory if:

- Conveyor has more than two turns.
- Conveyor includes sloped section to operate on more than one horizontal plane.
- Conveyor exceeds above dimensions. Location of turns in relation to drives may allow additional length per drive.
- If tote boxes or dish racks are conveyed.

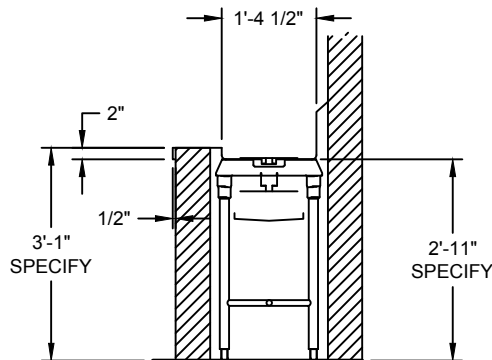

Typical Section View at Tray-Drop

Optional Features:

See Accessories Sheet for complete listings

Conveyor Bed Configuration:

See Section View Sheet for complete Details

CADDY CORPORATION
509 Sharptown Road P.O. Box 345
Bridgeport, NJ 08014-0345
Tel: 856-467-4222 Fax: 856-467-5511
internet: www.caddycorp.com

SOILED TRAY CONVEYOR 21-C SERIES

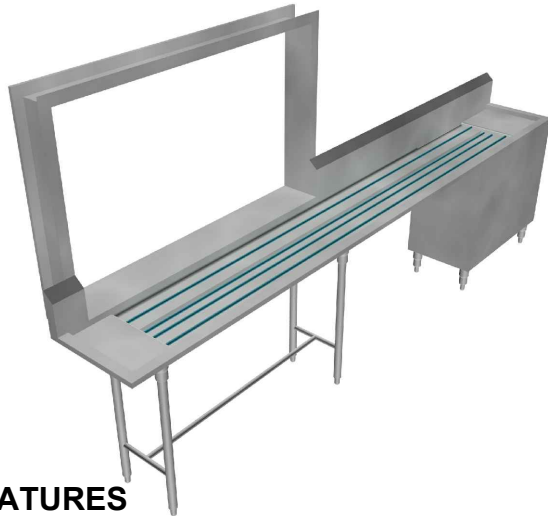

FEATURES

- Cleanliness
- No drip pans
- No chains
- No beltwasher
- No detergent pumps
- No concealed belt returns
- No hard to reach areas

SPECIFICATIONS:

Series 21-C Soiled tray conveyor to be as manufactured by Caddy Corporation. Patent \square 5,052,548, U.L. and N.S.F. listed with labels affixed. (5 year limited warrant, i.e. standard 90-day electrical \square 1-year parts and service \square 4 year prorated parts.)

Unit shall be as detailed on the plan and to accommodate 14"x18" or 15"x20" flat bottom trays. Other size trays can be accommodated upon request. (Specify dimensions of trays to be used.)

Conveyor belt to consist of dual 1/2" diameter Dura-San belting with 1,000 lbs. ultimate tensile strength. Belting itself is USDA accepted, highly resistant to abrasion, dirt, oil and most chemicals, maintains tension without springs, sprockets or links, continuous without ends or mechanical connection devices. Bands have special textured surface to reduce friction.

Conveyor to be table top type without concealed return belts, drain pans or a beltwasher under the conveyor. Penetrations in the conveyor bed are not allowed. All the bearings to be stainless steel heavy duty ball type, with sealed lubrication.

Conveyor bed to be 14 gauge stainless steel bed with longitudinal intersections rounded on 3/4" radius. Joints to be of welded construction, ground and polished to a uniform \square 4 finish. Stainless steel channel cross braces on approximately 5'-0" centers to be provided supporting the bed.

Curved section(s) to have positive hold-down tracks made of nonmetallic material at least 3/4" thick with built-in solid lubricant for continuous lubrication of bands. Materials that transmit heat due to high friction and resistance are not acceptable. Band capable of movement through a turn of 22" radius to the center of the conveyor. (Other Radii available upon request.)

Intermediate supports of the conveyor to consist of 1 5/8" O.D. stainless steel "H" frame legs with 1" O.D. stainless steel cross bracing completely welded, finished and provided with adjustable stainless steel bullet shaped feet. (Flanged feet also available).

Conveyor to be provided with a removable access panel at tail end providing access to bearings and adjustment. Drive housing to consist of 18 gauge stainless steel enclosure on two sides with removable 18 gauge panel. Frame of drive housing to be 2" x 2" angles stainless steel superstructure and to set on 6 1/2" high adjustable stainless steel feet.

Drive assembly to be at discharge end. D.C. controller to be solid state SCR type with built-in electronic torque control and infinite variable speed from zero to 40 feet per minute. Conveyor belt to be driven by reduction gearhead washdown type D.C. motor B.I.S.S.C. certified for the food industry, free of bacteria trapping surfaces. D.C. motor to eliminate high torque in case of jamming condition of the conveyor. Motor to be controlled manually by an on/off switch and automatically through a limit switch as required by application. All wired to the watertight controller with overload protection, in NEMA 4 type enclosure.

Optional Features:

See Accessories Sheet for complete listings

Conveyor Bed Configuration:

See Section View Sheet for complete Details

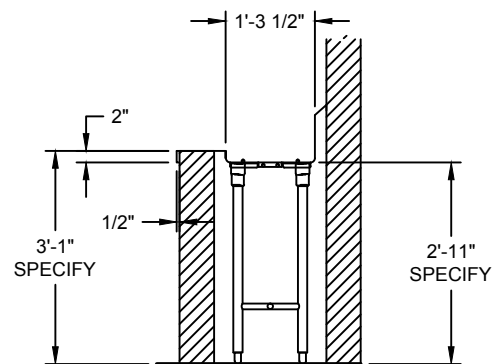

Typical Section View at Tray-Drop

**SOILED TRAY CONVEYOR
21-C SERIES**



TYPICAL ROUGHING, PLUMBING AND ELECTRICAL DATA

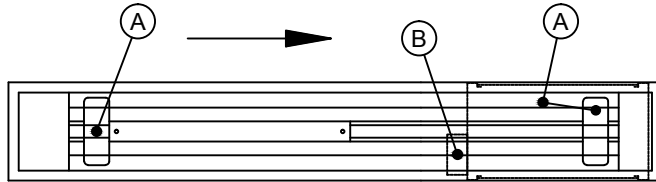

ROUGH-IN SCHEDULE	
NOTE: ALL ROUGH-INS TO BE 4" AFF	
SYM	DESCRIPTION
A	1 1/2" I.P.S. WASTE
B	120v., 60hz., 1ph. 15amps or 208v., 60hz., 1ph. 15amps (see motor size below)

NOTE: All roughings from floor should be stubbed up 4" A.F.F. (All roughings extending from wall should be 10" A.F.F.)

Conveyors with any type of turns require additional drain(s) as determined by application.

Motor sizes for soiled tray conveyors:

1/2 HP up to 30 ft.
3/4 HP up to 45 ft.
STRAIGHT

1/2 HP up to 20ft.
3/4 HP 21 to 35 ft.
**L-SHAPED
ONE 90°
TURN**

2 TURNS
Conveyors containing more than one turn may require two or more drive locations. Please contact factory for H.P. ratings.

Consult factory if:

- Conveyor has more than two turns.
- Conveyor includes sloped section to operate on more than one horizontal plane.
- Conveyor exceeds above dimensions. Location of turns in relation to drives may allow additional length per drive.

CADDY CORPORATION
509 Sharptown Road P.O. Box 345
Bridgeport, NJ 08014-0345
Tel: 856-467-4222 Fax: 856-467-5511
internet: www.caddycorp.com



SOILED TRAY CONVEYOR MT-12 SERIES

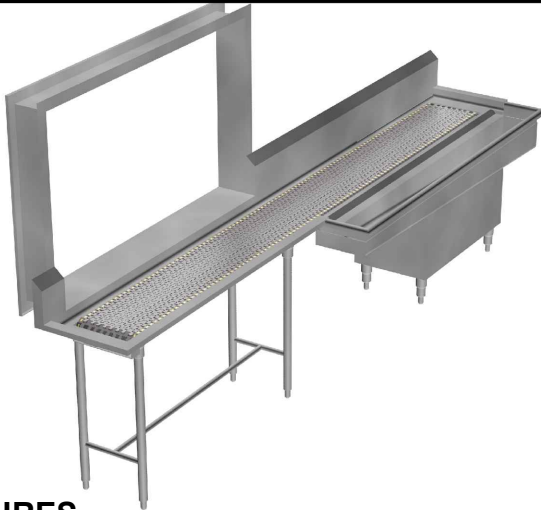

FEATURES

- Multi-directional, straight or curved, level or inclined
- Transports various objects an sizes (Tray or Trayless)
- Various width belts: 6", 12", 15", 18", 24", or 30"

SPECIFICATIONS:

Series MT-12 Soiled tray conveyor to be as manufactured by Caddy Corporation. U.L. and N.S.F. listed with labels affixed. Unit shall be as detailed on the plan and to normally accommodate up to 16" wide trays. Other size trays can be accommodated upon request. (Specify dimensions of item to be used.)

Conveyor belt to consist of low friction polycarbonate compound and replaceable without the use of special tools and disassembling of entire belt. The assembled belt to allow multi-directional installation. Plastic mesh not to overlap in any position to provide effective access of cleaning agents to all parts of the assembled belt and conveyor bed.

Conveyor bed to be 14 gauge stainless steel bed with longitudinal intersections rounded on 3/4" radius. Joints to be of welded construction, ground and polished to a uniform #4 finish. Stainless steel channel cross braces on approximately 5'-0" centers to be provided supporting the bed and side track. Conveyor belt to ride in a recessed self-lubricating track allowing continuous drainage of conveyor bed.

Curved section(s) to have positive hold-down tracks made of nonmetallic material at least 1/2" thick with built-in solid lubricant for continuous lubrication of belts. Materials that transmit heat due to high friction and resistance are not acceptable. Belt capable of movement through a turn of 22" radius to the center of the conveyor. (Other radii available upon request.)

Intermediate supports of the conveyor to consist of 1 5/8" O.D. stainless steel "H" frame legs with 1" O.D. stainless steel cross bracing completely welded, finished and provided with adjustable stainless steel bullet shaped feet. (Flanged feet also available).

Drive housing to consist of 18 gauge stainless steel enclosure on two sides with removable rear panel and opposite hinged access door with full height pull.

Frame of drive housing to be 2" x 2" angles stainless steel superstructure and to set on 6-1/2" high adjustable stainless steel feet.

Drive assembly to be at discharge end. D.C. controller to be solid state SCR type with built-in electronic torque control and infinite variable speed from zero to 40 feet per minute. Maximum chain pull not to exceed 250 lbs. at any point on conveyor. Conveyor chain to be driven by reduction gearhead wash down type D.C. motor to eliminate high torque in case of jamming condition of the conveyor. Motor can also be held in locked rotor position without damage to conveyor. Motor to be controlled manually by an on/off switch and automatically through a limit switch as required by application. All wired to the watertight SCR solid state D.C. controller with overload protection, in NEMA 4 type enclosure.

BWF belt washer to consist of welded 16 gauge stainless steel. Belt washer to have top and bottom fan shaped sprays arranged so lukewarm water thoroughly washes all belt surfaces after which belt is wiped continuously. Belt washer to have hinged drop-down, splash proof stainless steel access door. Washer to be fitted with interconnected water pressure reducing valve, water pressure gauge, shutoff valve and thermostatically controlled mixing valve with check valves. Bottom of belt washer to have 1 1/2" drain with tailpiece and two removable stainless steel perforated scrap baskets. Belt washer piping to be complete with approved type vacuum breaker and check valve. All piping exposed to view to be chrome plated.

Skirting to consist of 18 gauge stainless steel pan type panels with welded corners.

Conveyor to be furnished with an 18 gauge stainless steel catch pan under full length of conveyor. Catch pan to be pitched towards belt washer.

(Continue specifications for conveyor in excess of 20'-0" long)

Intermediate Drain

Catch pan(s) also to be pitched to intermediate swill sink(s) measuring approximately 10"x16"x4" deep of stainless steel construction with perforated removable stainless steel scrap basket and 1-1/2" drain with tailpiece.

MT-12 Conveyor Optional Features:

Fixed Speed Requirement

Variable speed control to have locking cover for non-tampering when fixed speed is desired.



CADDY CORPORATION

509 Sharptown Road P.O. Box 345
Bridgeport, NJ 08014-0345
Tel: 856-467-4222 Fax: 856-467-5511
internet: www.caddycorp.com

ITEM NO: _____

**SOILED TRAY CONVEYOR
MT-12 SERIES**



PROJECT: _____

LOCATION: _____

Optional Accessories Continue:

Intermediate Drive

Drive assembly(s) to be installed at intermediate location(s) without break in conveyor belt and belt bed.

Automatic Water Saver Control for Fresh Water Belt Washer

Operation of belt washer to be controlled by solenoid valve integrally wired to On/Off switch of conveyor to provide automatic operation of belt washer while conveyor is running. A separate On/Off switch to be provided to permit operation of conveyor without belt washer.

Belt Washer with Recirculating Water

BWR belt washer to consist of welded 16 gauge stainless steel. Belt washer to have top and bottom fan shaped sprays arranged so lukewarm water thoroughly washes all belt surfaces after which belt is wiped continuously. Belt washer to have hinged drop-down, splash proof stainless steel access door. Washer to be fitted with interconnected water pressure reducing valve, water pressure gauge, shutoff valve and thermostatically controlled mixing valve

with check valves. Bottom of belt washer to have 1 1/2" drain with tailpiece and two removable stainless steel perforated scrap baskets, and removable constant overflow standpipe to maintain water level. A pump to be provided to recirculate water from reservoir through spray nozzles. Recirculating system to include a removable filter to facilitate cleaning. Operation of belt washer to be controlled by solenoid valve integrally wired to On/Off switch of conveyor to provide automatic operation of belt washer while conveyor is running. A separate On/Off switch to be provided to permit operation of conveyor without belt washer.

Timed Belt Washing Cycle (for clean-up operations)

Belt washer to be controlled by automatic timer activated by a push button switch inside belt washer housing in such a manner that conveyor and belt washer will operate without interruption for an adjustable cycle of up to 16 minutes. After completion of wash cycle conveyor is ready for next start-up.

Detergent Injector (for maximum sanitation)

A pump type detergent injector working in conjunction with the belt washer water supply to be furnished.

Housings for Drive and Belt Washer

Specifying an intermediate drive (or drives) in your conveyor design provides unlimited options to meet architectural, operational, safety, and efficiency criteria.

U.L. listing of your custom conveyor up to 500 feet long (and more) with one single belt, unbroken by troublesome transfer points, is standard when specified.

The ability to locate the belt washer separately from the drive, if necessary, to accommodate access and sanitary consideration, is an important option.

End Drive With Belt Washer

End Drive Without Belt Washer

Intermediate Drive With Belt Washer

Intermediate Drive Without Belt Washer

Intermediate Belt Washer

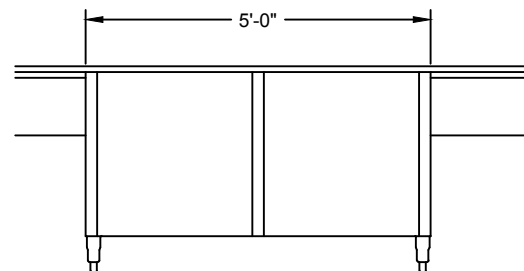
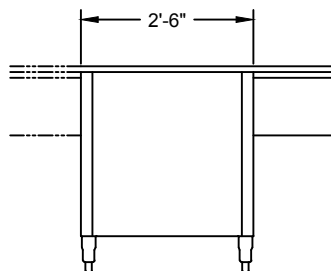
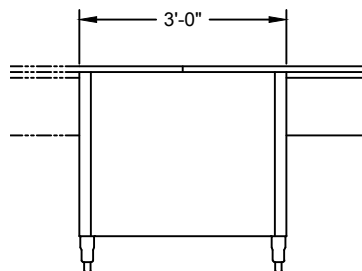

CADDY CORPORATION
 509 Sharptown Road P.O. Box 345
 Bridgeport, NJ 08014-0345
 Tel: 856-467-4222 Fax: 856-467-5511
 internet: www.caddycorp.com

**SOILED TRAY CONVEYOR
MT-12 SERIES**



Optional Accessories Continue:

TYPICAL ROUGHING, PLUMBING AND ELECTRICAL DATA

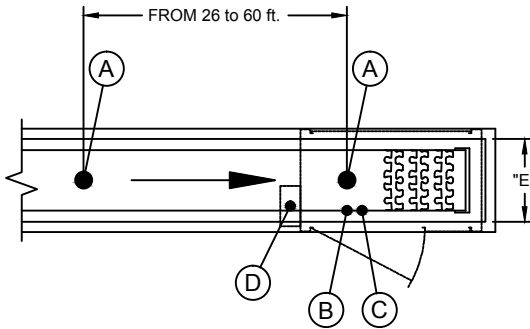

ROUGH-IN SCHEDULE	
NOTE: ALL ROUGH-INS TO BE 4" AFF	
SYM	DESCRIPTION
A	1 1/2" I.P.S. WASTE
B	1/2" I.P.S. HOT WATER
C	1/2" I.P.S. COLD WATER
D	ELECTRICAL CONNECTION

NOTE: All roughings from floor should be stubbed up 4" A.F.F. (All roughings extending from wall should be 10" A.F.F.)

BED WIDTH	
OBJECT TRANSPORTED	"E"
14" □ 18" AND 15" □ 20"	16 1/2"
16" □ 22" AND 16 1/2" □ 22"	18"
20" □ 20"	22"

Conveyors over 20 ft. long require additional drain(s) as determined by application.

ELECTRICAL CHARACTERISTICS

Motors available for 120/60 Hz. single phase up to and including 3/4 hp. Motors 1/2 hp. and 3/4 hp. are also available for 208/220/60 Hz. single phase.

Motor sizes for soiled tray conveyors:

STRAIGHT
1/4 HP up to 25 ft.
1/2 HP 26 to 50 ft.
3/4 HP 51 to 75 ft.

U-SHAPED
1/2 HP up to 25 ft.
3/4 HP 26 to 40 ft.

L-SHAPED ONE 90° TURN
1/4 HP up to 20 ft.
1/2 HP up to 39ft.
3/4 HP up to 56 ft.

2 TURNS
1/2 HP up to 25 ft.
3/4 HP 26 to 40 ft.

Consult factory if:

- Conveyor has more than two turns.
- Conveyor includes sloped section to operate on more than one horizontal plane.
- Conveyor exceeds above dimensions. Location of turns in relation to drives may allow additional length per drive.
- If tote boxes or dish racks are conveyed.

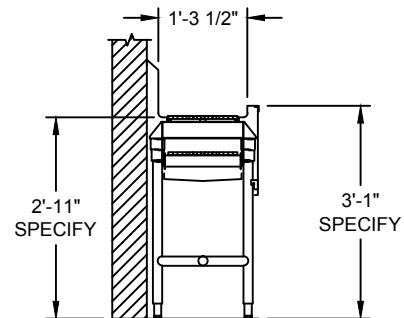

Typical Section View at Tray-Drop

Optional Features:

See Accessories Sheet for complete listings

Conveyor Bed Configuration:

See Section View Sheet for complete Details

CADDY CORPORATION
509 Sharptown Road P.O. Box 345
Bridgeport, NJ 08014-0345
Tel: 856-467-4222 Fax: 856-467-5511
internet: www.caddycorp.com



SOILED TRAY CONVEYOR Conveyor Bed Configuration



Conveyor Bed Configuration:

 Type A

Tray drop sill with 10" high splash adjacent to walls.

 Type B

Free standing section(s) with channel rim curbing(s) on both sides.

 Type C

10" high splash adjacent to wall(s) and channel rim front curbing.

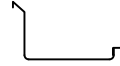
 Type D

10" high splash between two walls

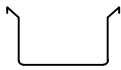
 Type E

10" high splash adjacent to wall(s) and rolled rim front curbing

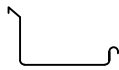

 Type F

Discharge from bed directly onto dish table

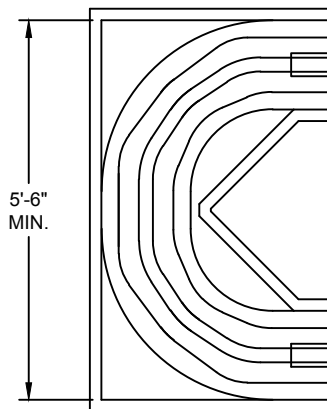

Minimum Bed Configuration:

21-C Double Turn



CF-10 Double Turn

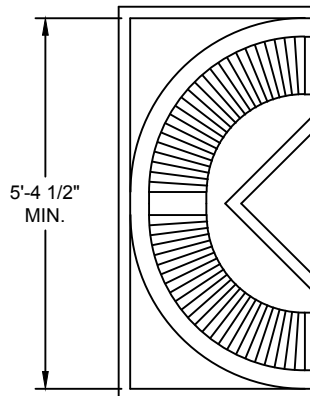

CF-10 Turn and Housing

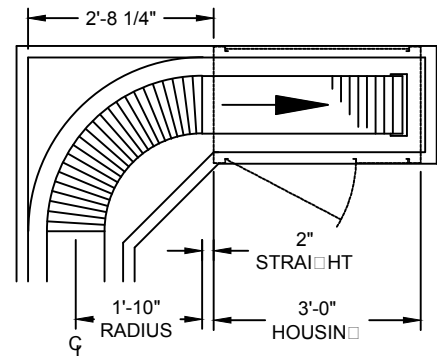

MT-12 Double Turn

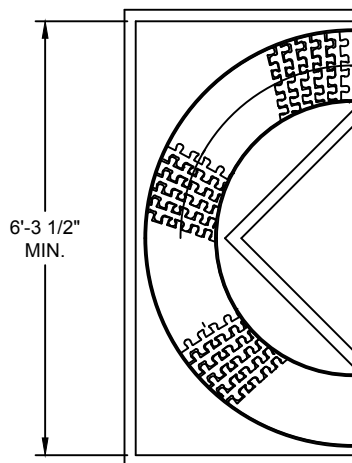

MT-12 Turn and Housing

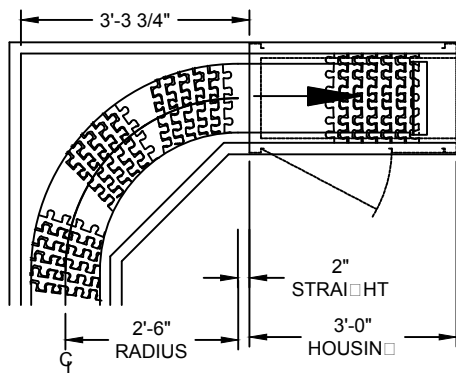

CADDY CORPORATION
 509 Sharptown Road P.O. Box 345
 Bridgeport, NJ 08014-0345
 Tel: 856-467-4222 Fax: 856-467-5511
 internet: www.caddycorp.com

**SOILED TRAY CONVEYOR
ACCESSORIES**



Optional Accessories:

D-D Pass Windows

Window buck to be constructed of 14 gauge stainless steel flanged out 1/2" x 2" on both sides of the wall, forming a continuous frame. Corners to be completely closed, welded and polished to a uniform finish.

(When door is required for security or for other reason, continue specifications)

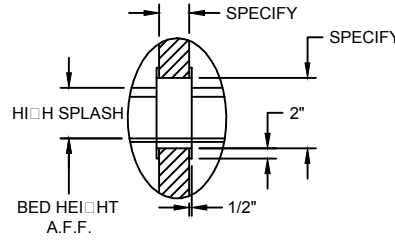

TYPICAL SECTION OF CONVEYOR DOOR WINDOW BUCK

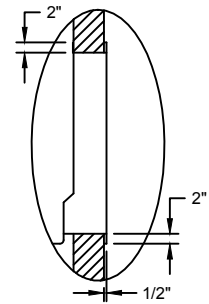

TYPICAL SECTION OF TRAY-DROP WINDOW BUCK AND SILL MODEL DD WITHOUT SLIDE-UP DOOR

Slide-Up Door

Slide-Up door to be of double wall 18 gauge stainless steel and sound deadened. Size as detailed on plan. Door guides of 16 gauge stainless steel and of sufficient height so door will completely clear the buck opening when in the raised position. Door guides of one-piece construction with guide slots for sliding door. Top of guides to be furnished with concealed, self-lubricating noiseless pulley assemblies. Door to be suspended from 1/8" thick aircraft cables with suitable counterweights, designed for noiseless operation. Tops of door guides to be fully enclosed. Space between door guides above window opening to be provided with 20 gauge stainless steel panel mounted flush with front of guides to conceal door when in open position. Door to be provided with handle and latch or key.

(Continue specifications by selecting door style)

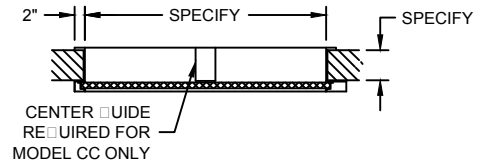

TYPICAL PLAN VIEW OF TRAY-DROP WITH SLIDE-UP DOOR MODEL BB AND CC

Model A-A

Direct entry type. Single door

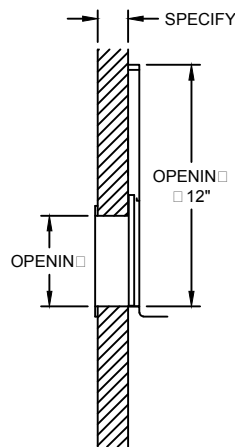

Model B-B

Side entry type. Single door



Model C-C

Side entry type. Double door with 4" wide centered vertical guide.



Fire Door

Door to be 1-1/2 hour. Class "B" with U.L. label

SOILED TRAY CONVEYOR ACCESSORIES



Optional Accessories Continue:

Sight and Sound Baffle

Baffle to extend 2" above top of window opening with full enclosure at both ends, top and rear. End enclosure next to dish room to end 12" above the conveyor bed. The entire sight and sound baffle to be of double wall 18 gauge stainless steel construction with sound deadening filler throughout. Rear of sight and sound baffle to be fitted with double wall removable access panel. The top to have a light fixture.

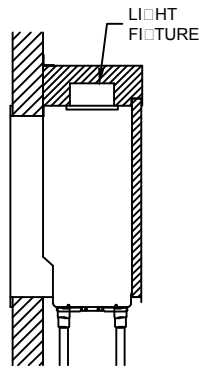

Full Height Skirting

Skirting at tray drop to consist of removable 3/4" thick plywood panels with waterproof backing and plastic lamination (color or pattern to be selected later) on front and all edges. This section of conveyor to be set on 6" high recessed 14 gauge stainless steel toe base.

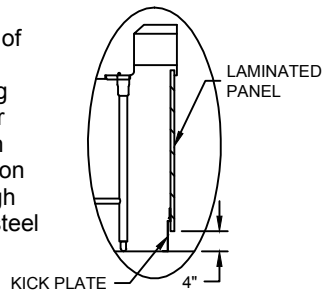

Soiled Dish Table

Table to be provided. Table and conveyor bed to be coordinated as one entire homogeneous unit to reduce field welding. Dish table to be constructed of 14 gauge stainless steel with all exposed edges finished in a 3" high curbing with 1 1/2" diameter 180 degree rolled rim with corners bullnosed. All corners to be rounded horizontally and vertically forming a cove at intersection. Joints to be continuously welded, ground and polished to a \square finish to appear as one continuous surface free of buckles and weld marks. Next to conveyor bed, the table surface is to be sloped up at a 45 degree angle. Top to be cross braced with 14 gauge stainless steel channel stiffeners welded to the underside. Cross stiffeners to be at leg assembly stations on approximately 5'-0" centers. Legs to be constructed as specified for the conveyor with cross bracing as required to provide a rigid assembly.

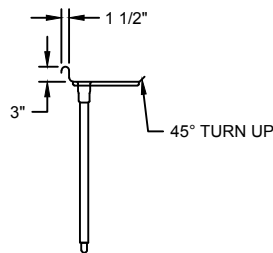

Scrapping Trough

Trough to be made of the same material as adjoining dish table and constructed integrally with the same. Trough bottom to be pitched to a disposal unit and to have corners coved to a 3/4" radius. Where the trough intersects disposer sink, it is to be continuously welded. Weld to be ground smooth and polished to a uniform finish. Trough bottom to be provided with water flushing devices to simplify flushing of entire trough bottom. The disposer sink station to be as

dimensioned on drawing. Sink to be made of 14 gauge stainless steel with all corners coved. Seam between sink and top to be continuously welded. Where trough meets disposer sink station it is to be fitted with a silver saver barrier consisting of a stainless steel horizontal rod properly spaced to prevent silverware from entering the disposer. (Disposer adapter ring furnished by manufacture of the disposer.) Seam between disposer and adapter ring and sink bottom to be continuously welded, ground smooth and polished.

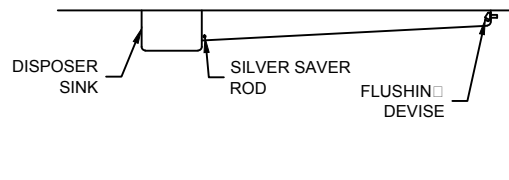

Double Overhead Racking and Storage Shelves

Sloped lower racking shelf to be constructed of 14 gauge stainless steel with shelf surface measuring 22" in width and sloped up toward rear at a 40 degree angle. Shelf to have 2" high curbing at front. The rim of front curbing to have 1" wide channel facing rear to provided space inside for liquid accumulation. Rear and ends of shelf to have 2" high vertical risers. Lower edge of shelf to have drain holes. Shelf to be attached to 12 gauge stainless steel cantilever brackets. Brackets to consist of a triangular shaped plate and a stainless steel angle welded to the underside of shelf. Plates and angles to have rows of conforming slots to permit front to back adjustment of shelf. Each bracket to be provided with two stainless steel truss head bolts and stainless steel nuts.

A 16" wide adjustable, flat upper shelf is also to be provided for storage of empty dishwasher racks. Shelf to have turned down channel edge at front and 2" high riser at rear. Both ends to be fitted with 16" high "U" shaped rack supports made of 3/8" diameter stainless steel rod.

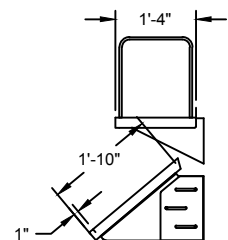



SOILED TRAY CONVEYOR ACCESSORIES



Optional Accessories Continue:

Single Overhead Racking Shelf

Sloped racking shelf to be constructed of 14 gauge stainless steel with shelf surface measuring 22" in width and sloped up toward rear at a 40 degree angle. Shelf to have 2" high curbing at front. The rim of front curbing to have 1" wide channel facing rear to provide space inside for liquid accumulation. Rear and ends of shelf to have 2" high vertical risers. Lower edge of shelf to have drain holes. Shelf to be attached to 12 gauge stainless steel cantilever brackets. Brackets to consist of a triangular shaped plate and a stainless steel angle welded to the underside of shelf. Plates and angles to have rows of conforming slots to permit front to back adjustment of shelf. Each bracket to be provided with two stainless steel truss head bolts and stainless steel cap nuts.

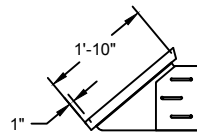

Single Overhead Storage Shelf

Flat storage shelf to be constructed of 14 gauge stainless steel with shelf surface measuring 16" wide. Shelf to have turned down channel edge at front and 2" high riser at rear. Both ends to be fitted with 16" high "U" shaped rack supports made of 3/8" diameter stainless steel rod. Shelf to be attached to 12 gauge stainless steel cantilever brackets. Brackets to be welded to the underside of shelf. Plates and angles to have rows of conforming slots to permit front to back adjustment of shelf. Each bracket to be provided with two stainless steel truss head bolts and stainless steel nuts.

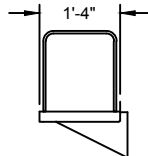

Wall Mounted Shelf(s)

Shelf to be supported by 1 1/2" x 1 1/2" x 1/8" thick stainless steel angles. Angles to measure 18" long for single shelf and 30" long for double shelves. One leg of each angle which protrudes from wall and to which shelf bracket is attached to be provided with a row of bolt holes over full length of the angle and spaced 1" apart to facilitate vertical adjustment of shelf. Bracket to be fastened to angles with stainless steel bolts and nuts.

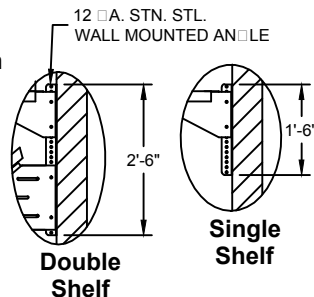

Tubular Mounted Shelf(s)

Shelf to be supported by 1 5/8" O.D. stainless steel tubular uprights which are integrally attached to the leg assembly. Uprights to be fitted with stainless steel sleeves to which shelf brackets are welded. Sleeves to have set screws to facilitate vertical adjustment of shelf.

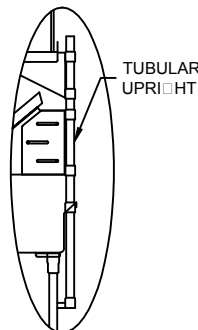

Cantilever Wall Supports (in lieu of legs)

Brackets to be 12 gauge polished stainless steel spaced as required by application. (6'-0" maximum)

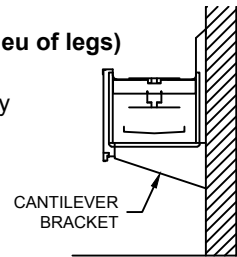

Time Delay Limit Switch

Electronic, receiver-transmitter photo electric cell type switch assembly installed and located on the conveyor bed to operate as a monitor for trays passing on the conveyor belts at a predetermined location. Conveyor belts stop when a tray sits for a predetermined amount of time in front of the eye, and restart when the tray is removed. Switch to be activated by tray passing through eye's beam. Control to be integrally wired into main circuitry of conveyor drive mechanism eliminating additional wiring work on the part of the electrical contractor making final connection to the conveyor system.

End Limit Switch

Electronic, receiver-transmitter photo electric cell type switch assembly installed and located on the conveyor bed to operate as a monitor for trays passing on the conveyor belts at a predetermined location. Conveyor belts stop when a tray breaks the light beam, and restart when the tray is removed. Switch to be activated by tray passing through eye's beam. Control to be integrally wired into main circuitry of conveyor drive mechanism eliminating additional wiring work on the part of the electrical contractor making final connection to the conveyor system.

Accumulation Feature

Trays to electronically transfer from traydrop conveyor to accumulation conveyor and accumulate the entire length of the accumulation conveyor. At this point a remote audio-visual indicator will advise that the system is full and ready for scrapping.

**SOILED TRAY CONVEYOR
ACCESSORIES****Optional Accessories Continue:** **Idler Roller Accumulator**

Roller pan to be the same width as the adjacent conveyor bed. Bed of idler roller section to be depressed 2" with the bottom pitched to a 1-1/2" drain. Rollers to be spaced on approximately 4" centers.

(Continue specifications by selecting stationary or drop-in model)

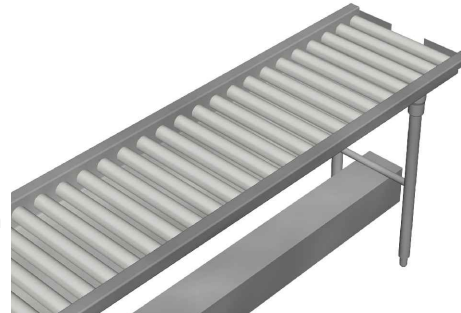
 **Stationary Rollers**

Rollers to be mounted directly into vertical surfaces of roller pan through .328" diameter holes.

(Continue specifications by selecting stainless steel or plastic rollers)

 R-35-S - Stainless Steel Rollers

1.9" O.D. roller consists of non-corrosive N.S.F. style bearings, stainless steel tube, nylon stub shafts, and stainless steel screws. Rollers to be removable only with use of tools.

 R-40-P - Plastic Rollers

1.9" O.D. roller consists of non-corrosive N.S.F. style bearings, P.V.C. tube, nylon stub shafts, and stainless steel screws. Rollers to be removable only with use of tools.

**Raised Roller Section** **Drop-In Roller Sections**

Drop-in roller section to consist of removable section approximate 30" long. Rollers to be set in an angle frame of 12 gauge stainless steel through .328" diameter holes.

(Continue specifications by selecting raised rollers or recessed rollers)

 Raised Roller Sections

Top of roller to be 1/4" above top of drop-in roller frame.

(Continue specifications by selecting stainless steel or plastic rollers)

RA-28-S - stainless steel rollers (R-35-S) spaced on approximately 4" centers

RA-29-P - plastic rollers (R-40-P) spaced on approximately 4" centers

 Recessed Roller Sections

Top of roller to be $\frac{7}{8}$ " below top of drop-in roller frame.

(Continue specifications by selecting stainless steel or plastic rollers)

RA-32-S - stainless steel rollers (R-35-S) spaced on approximately 4" centers

RA-33-P - plastic rollers (R-40-S) spaced on approximately 4" centers

**Recessed Roller Section**

RA-30-S - stainless steel rollers (R-35-S) spaced on approximately 6" centers

RA-31-P - plastic rollers (R-40-P) spaced on approximately 6" centers

RA-34-S - stainless steel rollers (R-35-S) spaced on approximately 6" centers

RA-35-P - plastic rollers (R-40-P) spaced on approximately 6" centers

(Indicate in specification the overall length and width of each section required)

**SOILED TRAY CONVEYOR
ACCESSORIES**



Optional Accessories Continue:

Curved Roller Sections

Curved roller section to consist of removable radius section forming an angle of approximately 45°. Rollers to be set in a frame of 12 gauge stainless steel flat bar with 12 gauge stainless steel angle crossbars at both ends and 12 gauge stainless steel flat bar at intermediate location. Rollers to be set in frame through .328" diameter holes.

(Continue specifications by selecting stainless steel or plastic rollers)

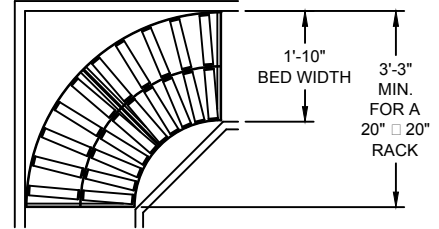

RA-36-S - stainless steel rollers (R-35-S) spaced on approximately 4" centers

RA-37-P - plastic rollers (R-40-P) spaced on approximately 4" centers

Stationary Skatewheels (plastic only)

1.9" O.D. plastic skatewheel with stainless steel sleeves and ball bearings

S-50 Skatewheel
1.9" O.D. skatewheel

S-51 Skatewheel with mounting stud
Skatewheel with stainless steel mounting stud and lock nut.

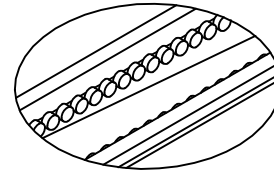

Drop-In Skatewheel Sections

Skatewheel accumulator to consist of removable section approximately ___" long. Skatewheel to be set in an angle frame of 16 and 14 gauge stainless steel. All skatewheels to be approximately 1.9" O.D. and easily replaceable. Overall height of frame to be 2-5/16". (Include in specification overall length and width of sections).

(Continue specifications by selecting raised rollers or recessed rollers)

SA-45-P Section
Two rows of stainless ball bearing plastic skatewheels with stainless steel sleeves on approximately 2-1/4" centers.

SA-48-P Section
Four rows of stainless ball bearing plastic skatewheels with stainless steel sleeves on approximately 4-1/2" centers.

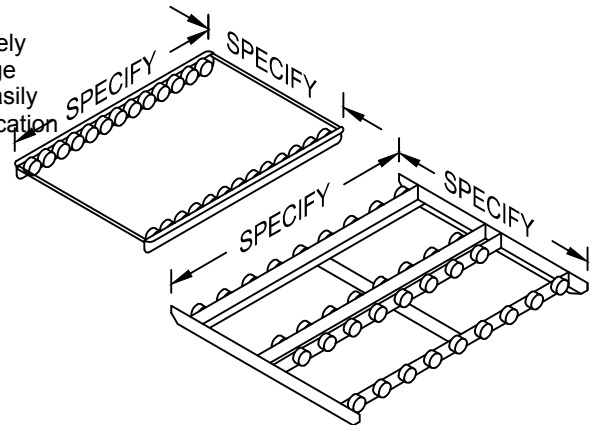

Mini Rollers

Mini rollers to be installed on both curbing of dishtable approximately 1" clear of the dishtable, all approximately on 4" centers. Rollers to be 1.9" O.D. x 5" long with solid 1/2" stainless steel shaft, reduced to 5/16" thread at mounting end. Roller complete with two 12 gauge stainless steel mounting support washers and stainless steel lock nut. Bearings at both ends of roller to be non-corrosive.

(Continue specifications by selecting stainless steel or plastic roller)

MR-14-S with Stainless Steel Rollers

MR-20-P with Noiseless Plastic Rollers

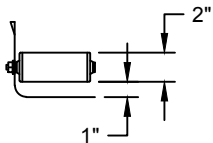
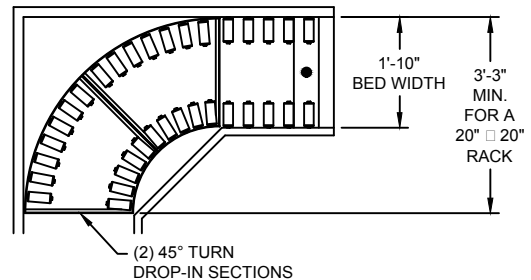

Punch 5/16" diameter hole. Set roller with 12 gauge stainless steel mounting washer on EACH side of dishtable curbing... and fasten with stainless steel lock nut.

CADDY CORPORATION
 509 Sharptown Road P.O. Box 345
 Bridgeport, NJ 08014-0345
 Tel: 856-467-4222 Fax: 856-467-5511
 internet: www.caddycorp.com



SOILED TRAY CONVEYOR ACCESSORIES



Optional Accessories Continue:

Gravity Tray Stacker

Tray stacker to be installed at discharge end of conveyor. Tray stacker bed to be of 14 gauge stainless steel, type 304 seamlessly formed, welded, ground and polished to match the finish of the conveyor. Removable 14 gauge stainless steel inset angle frame to have two rows of skatewheels with stainless steel ball bearings mounted on 2" centers. Width of tray stacker to accommodate 14" to 15" wide trays. Discharge end of the conveyor to be fitted with suitable guide clips to secure a tray stacker cart in proper loading position. Tray stacker to include a scanning switch at the end of the belt to allow only empty trays to pass and two monitoring, independently operating limit switches. One switch to close circuit to conveyor power drive when a tray stacker cart is in the proper stacking position and open circuit when cart is removed. Second switch to stop conveyor when stacking cart has been loaded to maximum capacity. All switches to be interwired to the conveyor drive so that only one final electrical connection is required in the field.

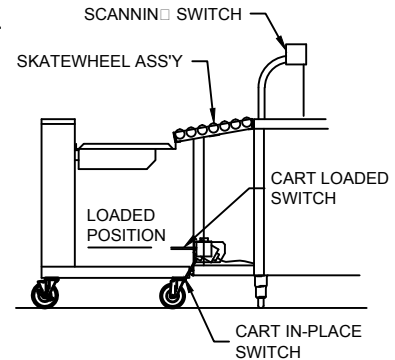

Powered Tray Stacker

Tray stacker to be 8" long and installed at discharge end of conveyor. Tray stacker bed to be of 14 gauge stainless steel, type 301 seamlessly formed, welded, ground and polished to match the finish of the conveyor. Stacker to have two plastic powered rollers geared to accelerate tray discharge. Rollers to be ball bearing type. Housing to have removable stainless steel access panel and clearance under rollers for easy cleaning and to be powered by a fractional horsepower motor with concealed drive. Motor to be interwired with drive motor of conveyor, with by-pass switch to allow deactivation of tray stacker. Tray stacker to accommodate 14" or 15" wide trays. Discharge end of the conveyor to be fitted with suitable guide clips to secure a tray stacker cart in proper loading position. Tray stacker to include a scanning switch at the end of the belt to allow only empty trays to pass and two monitoring, independently operating limit switches. One switch to close circuit to conveyor power drive when a tray stacker cart is in the proper stacking position and open circuit when cart is removed. Second switch to stop conveyor when stacking cart has been loaded to maximum capacity. All switches to be interwired to the conveyor drive so that only one final electrical connection is required in the field.

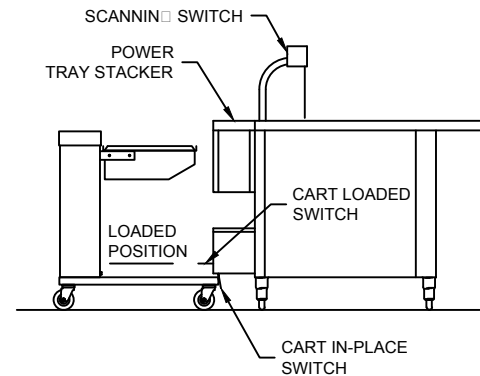

Tray Stacker Optional Features

Automatic Stacking Limit Switches

Tray stacker (power or gravity model) to be fitted with two monitoring, independently operating limit switches. One switch to close circuit to conveyor power drive when tray stacker truck is in proper stacking position and open circuit when truck is removed. Second switch to stop conveyor when Caddymagic stacking truck has been loaded to maximum capacity. Both switches to be interwired to conveyor drive so that only one final electrical connection is required in the field.

By-Pass Limit Switch

Switch to de-activate automatic stacking limit switches.

**SOILED TRAY CONVEYOR
ACCESSORIES**



Optional Accessories Continue:

Mobile Bridge

Mobile bridge to be constructed of 14 gauge stainless steel type 304 seamlessly formed, welded, ground and polished to match the finish of the conveyor. Size to be as required. Three sides of bridge to have 1-1/2" diameter 180 degree rolled rims. Fourth side to be turned down over raised edge of scrapping trough. Bridge to be supported by 1-5/8" O.D. stainless steel legs with 1" O.D. stainless steel "H" railing completely welded and finished, and provided with 5" diameter casters with polyurethane tires and foot brakes. Stainless steel leg sleeves with set screws to facilitate vertical adjustment to be welded to underside of bridge.



Removable Bridge

Removable bridge to be constructed of 14 gauge stainless steel type 304 seamlessly formed, welded, ground and polished to match the finish of the conveyor. Size to be as required. Two sides of bridge to have 1-1/2" diameter 180 degree rolled rims. Ends to be turned down over both supporting edges.

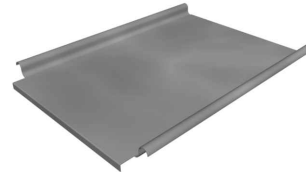

T-101 Silver Soak Sink

Sink to be 22" x 22" x 8" deep inside, constructed of 14 gauge stainless steel, with all interior corners coved and provided with 1-1/2" diameter 180 degree rolled rims on four sides ending in bullnosed corners. Sink bottom to be creased to a 1-1/2" twist handle waste outlet set into recessed die-stamped opening. Sink to have 10" legs made of 1-5/8" O.D. stainless steel tubing welded to be underside of the sink and furnished with 5" diameter casters with polyurethane tires and foot brakes.



Recycling Chute

Chute to be constructed of 14 gauge stainless steel flanged out 2" on the dining room side of the wall, forming continuous frame. Corners to be completely closed, welded and polished to a uniform finish.

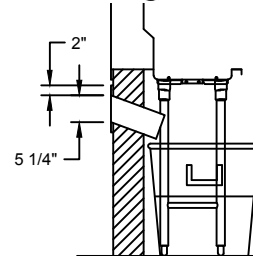

NEMA 4X Electrical Enclosure

Enclosure to be stainless steel in lieu of standard NEMA epoxy painted steel.

T-239 Silver Sorting Caddy

Silver sorting caddy to be 42" long x 26-1/2" wide x 35-7/8" high to table surface. Top of 14 gauge stainless steel turned up 2" on three sides with corners welded. Attendant's side of the table to have integrally constructed trough 4" deep x 4-1/4" wide to receive cutlery containers. Front of the trough to have a channel rim. Legs of 1-1/4" square stainless steel tubing, with three set of 14 gauge stainless steel angles spaced on 6" centers to receive 20"x20" silver racks. The unit to be provided with 5" polyurethane tires, two with foot brakes.



MODEL T-239

T-305 Bulk Silver Caddy

See Bulk Silver Caddy cutsheet for specifications

T-402 Tray & Silver Caddy

See Tray & Silver Caddy cutsheet for specifications

T-407 Bulk Silver Caddy

See Bulk Silver Caddy cutsheet for specifications

T-301 Tray & Silver Caddy

See Tray & Silver Caddy cutsheet for specifications



SOILED TRAY CONVEYOR STA-R

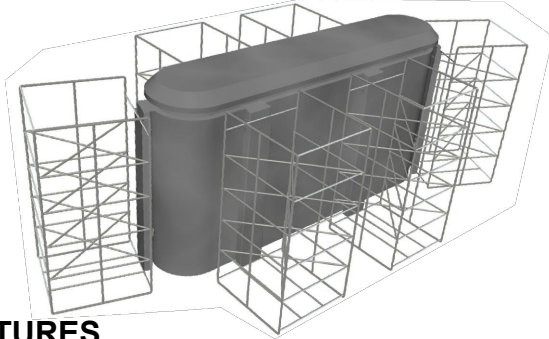

FEATURES

- Saves space
- Saves labor
- Easy cleaning
- Accumulates maximum trays in minimum space
- Accumulates trays while the staff attends to other duties

SPECIFICATIONS:

Series STA-R Soiled tray conveyor to be as manufactured by Caddy Corporation.

Unit shall be as detailed on the plan and to accommodate 14"x18" or 15"x20" flat bottom trays. Other size trays can be accommodated upon request. (Specify dimensions of trays to be used.)

Accumulator frame to be constructed of 1" x 1" stainless steel square tubing. Accumulator to be table-top mounted.

The drive assembly D.C. controller to be solid state SCR type with built-in electronic torque control and variable speed from zero to 20 feet per minute. Accumulator to be driven by reduction gearhead wash down type D.C. motor. D.C. motor to eliminate high torque in case of jamming condition. Motor can also be held in locked rotor position without damage to accumulator. Motor to be controlled manually by an on/off switch in NEMA 4 type enclosure, all wired to the watertight controller with overload protection.

Access panels to motor and gearing area, and radius panels on each end to be 18 gauge stainless steel.

Carriers to be removable and to consist of 5/16" diameter stainless steel rod type tray slides to minimize surface area cleaning and to facilitate visibility. Number of carriers to be determined by the overall length of the accumulator and shall be designed to accommodate.

Accumulator shall be provided with anti-jam switches which will quickly brake to a halt the forward movement of carriers in the event that a tray is not properly positioned in a carrier and restarted (after slight time delay) when tray is properly positioned.

The accumulator shall be designed and manufactured according to the standards as set forth by the National Sanitation Foundation (NSF).

Baffle wall to mount on top of STA-R. Top of baffle to extend from baffle wall to above window opening. The entire sight and sound baffle to be of double wall 18 gauge stainless steel construction with sound deadening filler throughout.

- Five trays (STA-R-50) or Four trays (STA-R-40)

Tray carriers shall be mechanically connected to chain, effectively producing a continuous rotation of carriers for accumulation of trays. Direction of rotation shall be coordinated with cafeteria traffic flow, and shall be either in a clockwise or counter clockwise rotation.

- Tray Drop Drip Pan

Drip pan to be 14 gauge stainless steel bed with longitudinal intersections rounded on 3/4" radius. Joints to be of welded construction, ground and polished to a uniform $\square 4$ finish. Stainless steel channel cross braces on approximately 5'-0" centers to be providing support under the bed. Intermediate supports of the conveyor to consist of 1-5/8" O.D. stainless steel legs with 1" O.D. stainless steel cross bracing completely welded, finished and provided with adjustable stainless steel feet. Bottom of drip pan to have 1-1/2" drain with tailpiece.

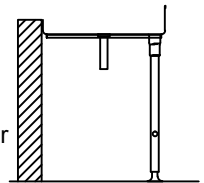

Optional Accessories:

- D-D Tray Drop Pass Windows

Window buck to be constructed of 14 gauge stainless steel flanged out 1/2"x2" on front side of the wall and 2"x2" single skin on kitchen side, forming continuous frame. Corners to be completely closed, welded and polished to a uniform finish.

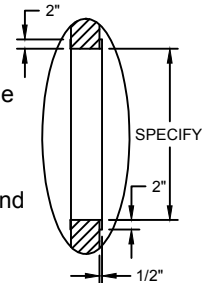

- Full Height Skirting

Skirting at tray drop to consist of removable 3/4" thick plywood panels with waterproof backing and plastic lamination (color or pattern to be selected later) on front and all edges. This section of conveyor to be set on 6" high recessed 14 gauge stainless steel toe base.

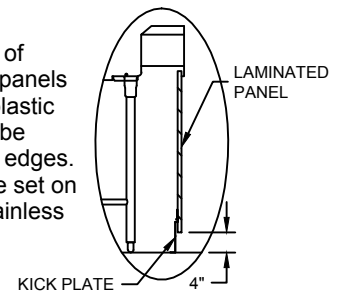

- Soiled Dishtable

Table to be provided. Table and conveyor bed to be coordinated as one entire homogeneous unit to reduce field welding. Dishtable to be constructed of 14 gauge stainless steel with all exposed edges finished in a 3" high curbing



CADDY CORPORATION

509 Sharptown Road P.O. Box 345
Bridgeport, NJ 08014-0345
Tel: 856-467-4222 Fax: 856-467-5511
internet: www.caddycorp.com

SOILED TRAY CONVEYOR STA-R



Optional Accessories Continued:

with 1-1/2" diameter 180 degree rolled rim with corners bullnosed. All corners to be rounded horizontally and vertically forming a cove at intersection. Joints to be continuously welded, ground and polished to a $\square 4$ finish to appear as one continuous surface free of buckles and weld marks. Next to conveyor bed, the table surface is to be sloped up at a 45 degree angle. Top to be cross braced with 14 gauge stainless steel channel stiffeners welded to the underside. Cross stiffeners to be at leg assembly stations on approximately 5'-0" centers. Legs to be constructed as specified for the conveyor with cross bracing as required to provide a rigid assembly.

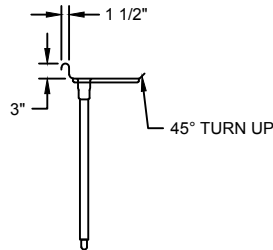

Scrapping Trough

Trough to be made of the same material as adjoining dishtable and constructed integrally with the same. Trough bottom to be pitched to a disposal unit and to have corners coved to a 3/4" radius. Where the trough intersects disposer sink, it is to be continuously welded. Weld to be ground smooth and polished to a uniform finish. Trough bottom to be provided with water flushing devices to simplify flushing of entire trough bottom. The disposer sink station to be as dimensioned on drawing. Sink made of 14 gauge stainless steel with all corners coved. Seam between sink and top to be continuously welded. Where trough meets disposer sink station it is to be fitted with a silver saver barrier consisting of a stainless steel horizontal rod properly spaced to prevent silverware from entering the disposer. (Disposer adapter ring furnished by manufacturer of the disposer.) Seam between disposer and adapter ring and sink bottom to be continuously welded, ground smooth and polished.

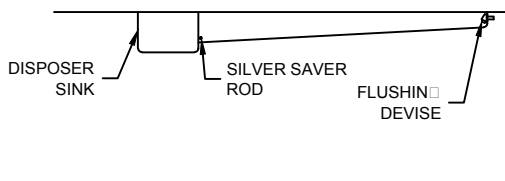

Mobile Racking Station

Table to be 14 gauge stainless steel bed with longitudinal intersections rounded on 3/4" radius. Joints to be of welded construction, ground and polished to a uniform $\square 4$ finish. Sides of racking station to have 1-1/2" diameter 180 degree rolled rims. Front end to have marine edge. Back side of racking station to have 8" high splash. Sloped racking shelf to be constructed of $\square 14$ gauge stainless steel with shelf surface measuring 22" in width and sloped up toward rear at a 40 degree angle. Shelf to have 2" high curbing at front. The rim of front curbing to have 1" wide channel facing rear to provided space inside for liquid accumulation. Rear and ends of shelf to have 2" high vertical risers. Lower edge of shelf to have drain holes. Shelf to be attached to 12 gauge stainless steel cantilever brackets. Brackets to be welded to the underside of shelf.

Shelf to be supported by 1-5/8" O.D. stainless steel

tubular uprights which are integrally attached to the leg assembly. Uprights to be fitted with stainless steel sleeves to which shelf brackets are welded. Sleeves to have set screws to facilitate vertical adjustment of shelf. Racking station to consist of 1-5/8" O.D. stainless steel legs with 1" O.D. stainless steel cross bracing spaced to receive 20" x 20" racks. Legs completely welded, finished and provided with 5" polyurethane tires, two with foot brakes.

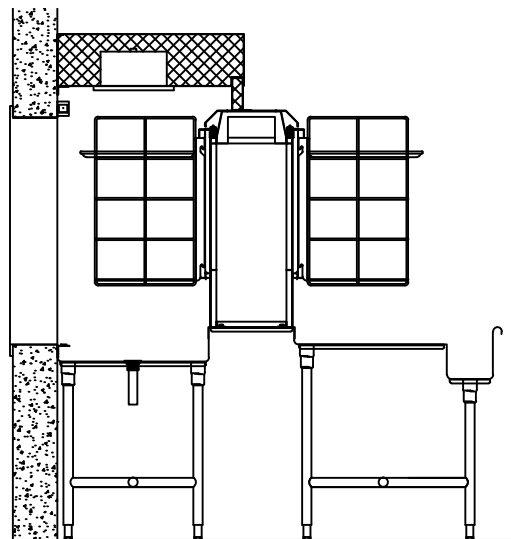
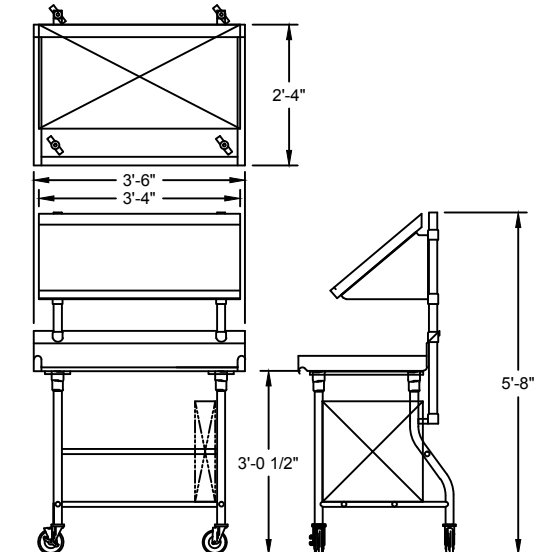

Typical Section of STA-R with optional Window Buck, Drip Pan and Soiled Table with Scrapping Trough

CADDY CORPORATION
 509 Sharptown Road P.O. Box 345
 Bridgeport, NJ 08014-0345
 Tel: 856-467-4222 Fax: 856-467-5511
 internet: www.caddycorp.com



BUSING CONVEYOR BU-10-10 SERIES



FEATURES

- **MOBILE:** no permanent electrical or plumbing connections needed.
- Dishes, cups and glasses are sorted directly onto conveyor
- Tableware is conveyed to loading area of dish washer.

SPECIFICATIONS:

Series BU-10-10 Busmaster conveyor to be as manufactured by Caddy Corporation. U.L. and N.S.F. listed with labels affixed. Unit shall be as detailed on the plan and provided with two 10" self-tracking stainless steel chain-type belts resulting in 20" wide conveying surface. Conveyor belt to consist of a stainless steel chain having approximately 3/4" pitch with 10" side snap-on type slats. Slats to have tapered edges on all sides and molded of low friction polycarbonate compound and replaceable without the use of special tools and disassembling of belt chain. Slats not to overlap in any position to provide effective access of cleaning agents to all parts of the assembled belt. Return belt to be suspended from monorail-type track. Belt speed factory-set at approximately 20 feet per minute. Conveyor to be suitable for conveying stacked loose dishes, dishwasher racks, trays and similar items,

Conveyor bed to be 14 gauge stainless steel turned up on all sides to form 3" high curbing. Conveyor to have full length catch pan pitched to drain with extension tubing.

Drive housing to consist of 18 gauge stainless steel enclosure on two sides with removable rear panel and opposite hinged access door with full height pull. Frame of drive housing to be 2"x2" angles stainless steel superstructure.

Conveyor at belt return level to be provided with removable easy-to-lock-in-place skirting panels of 18 gauge stainless steel.

Busmaster to have stainless steel channel cross braces on approximately 5'-0" centers to provide support under the bed and to the monorail belt return tracking system. Intermediate supports of the conveyor to consist of 1-5/8" O.D. stainless steel "H" frame legs with 1" O.D. stainless steel cross bracing completely welded, finished. Legs and housing to be fitted with heavy duty double ball bearing 5" diameter polyurethane tired swivel casters. Four end casters to have brakes.

Conveyor to be chain driven by reduction gearhead wash down type D.C. motor to eliminate high torque in case of jamming condition of the conveyor. Motor can also be held in locked rotor position without damage to conveyor.

Positive action motor brake to be provided to stop conveyor without coasting. Motor to be controlled manually by an on/off switch and a palm operated switch at discharge end wired so conveyor moves when switch is held in depressed position, all wired to the watertight SCR solid state D.C. controller with overload protection, in NEMA 4 type enclosure ready for plug-in to power supply. Drive to be fitted with 20 gauge stainless steel 360° chain guard. Conveyor shall have 6'-0" long power cord.

Conveyor to be furnished with an 18 gauge stainless steel catch pan under full length of conveyor. Catch pan to be pitched towards drain with extension tubing.

BU-10-10 Conveyor Optional Features:

Mobile Bridge

Mobile bridge to be constructed of 14 gauge stainless steel type 304 seamlessly formed, welded, ground and polished to match the finish of the conveyor. Size to be as required. Three sides of bridge to have 1-1/2" diameter 180 degree rolled rims. Fourth side to be turned down over raised edge of scrapping trough. Bridge to be supported by 1-5/8" O.D. stainless steel legs with 1" O.D. stainless steel "H" railing completely welded and finished, and provided with 5" diameter casters with polyurethane tires and foot brakes. Stainless steel leg sleeves with set screws to facilitate vertical adjustment to be welded to underside of bridge.



Motors

(Continue specifications by selecting motor electrical characteristic)

- 208 volts, 60 Hz, single phase.
- 208 volts, 60 Hz, three phase.
- 120 volts, 60 Hz, single phase (for Busmaster up to 25 ft.)

CADDY CORPORATION
509 Sharptown Road P.O. Box 345
Bridgeport, NJ 08014-0345
Tel: 856-467-4222 Fax: 856-467-5511
internet: www.caddycorp.com



SORTING CONVEYOR SV-10-10 SERIES

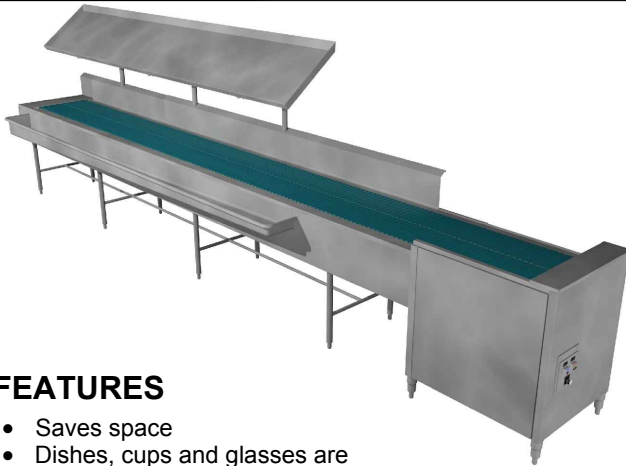

FEATURES

- Saves space
- Dishes, cups and glasses are sorted directly onto conveyor
- Tableware is conveyed to loading area of dish washer.

SPECIFICATIONS:

Series SV-10-10 Sorting-veyor to be as manufactured by Caddy Corporation. U.L. and N.S.F. listed with labels affixed. Unit shall be as detailed on the plan and provided with two 10" self-tracking stainless steel chain-type belts resulting in 20" wide conveying surface. Conveyor belt to consist of a stainless steel chain having approximately 3/4" pitch with 10" side snap-on type slats. Slats to have tapered edges on all sides and molded of low friction polycarbonate compound and replaceable without the use of special tools and disassembling of belt chain. Slats not to overlap in any position to provide effective access of cleaning agents to all parts of the assembled belt. Return belt to be suspended from monorail-type track. Belt speed factory-set at approximately 20 feet per minute. Conveyor to be suitable for conveying stacked loose dishes, dishwasher racks, trays and similar items, and to be provided with scrapping trough for stripping of soiled trays.

Conveyor bed to be 14 gauge stainless steel turned up adjacent to dishwashing machine to form 10" high curbing. Loading and unloading areas to have raised edges. Discharge end to be provided with palm operated switch wired so conveyor moves when switch is held in depressed position. Conveyor to have full length catch pan pitched to provide drainage.

Drive housing to consist of 18 gauge stainless steel enclosure on two sides with removable rear panel and opposite hinged access door with full height pull. Frame of drive housing to be 2"x2" angles stainless steel superstructure.

Rear sections of conveyor at belt return level to be provided with removable easy-to-lock-in-place skirting panels of 18 gauge stainless steel.

Sorting-veyor to have stainless steel channel cross braces on approximately 5'-0" centers to be providing support under the bed and to the monorail belt return tracking system. Intermediate supports of the conveyor to consist of 1-5/8" O.D. stainless steel "H" frame legs with 1" O.D. stainless steel cross bracing completely welded,

finished and provided with adjustable stainless steel bullet shaped feet.

Loading side of conveyor to be provided with scrapping trough of 14 gauge stainless steel bed with longitudinal intersections rounded on 3/4" radius. Trough bottom to be pitched to a disposal unit. Where the trough intersects disposer sink, it is to be continuously welded. Weld to be ground smooth and polished to a uniform finish. Trough bottom to be provided with water flushing devices to simplify flushing of entire trough bottom. The disposer sink station to be as dimensioned on drawing. Sink made of 14 gauge stainless steel with all corners coved. Seam between sink and top to be continuously welded. Where trough meets disposer sink station it is to be fitted with a silver saver barrier consisting of a stainless steel horizontal rod properly spaced to prevent silverware from entering the disposer. (Disposer adapter ring furnished by manufacturer of the disposer.) Seam between disposer and adapter ring and sink bottom to be continuously welded, ground smooth and polished. Rear of trough adjacent to conveyor to have full length rail to lock soiled trays in horizontal position.

Conveyor to be chain driven by reduction gearhead wash down type D.C. motor to eliminate high torque in case of jamming condition of the conveyor. Motor can also be held in locked rotor position without damage to conveyor. All wired to the watertight SCR solid state D.C. controller. with overload protection, in NEMA 4 type enclosure. Positive action motor brake to be provided to stop conveyor without coasting. Drive to be fitted with 20 gauge stainless steel 360° chain guard. All electrical components and motor to be conveniently located in the drive enclosure and completely interwired through splash proof flexible conduit and conduit connectors.

Sloped racking shelf to be of length as shown on drawing. Sloped racking shelf to be constructed of 14 gauge stainless steel with shelf surface measuring 22" in width and sloped up toward rear at a 40 degree angle. Shelf to have 2" high curbing at front. The rim of front curbing to have 1" wide channel facing rear to provide space inside for liquid accumulation. Rear and ends of shelf to have 2" high vertical risers. Lower edge of shelf to have drain holes. Shelf to be attached to 12 gauge stainless steel cantilever brackets. Brackets to consist of triangular shaped plate and a stainless steel angle welded to the underside of shelf. Plates and angles to have rows of conforming slots to permit front to back adjustment of shelf. Each bracket to be provided with two stainless steel truss head bolts and stainless steel nuts. Shelf to be supported by 1-5/8" O.D. stainless steel tubular uprights which are integrally attached to the leg assembly. Uprights to be fitted with stainless steel sleeves to which shelf brackets are welded. Sleeves to have set screws to facilitates vertical adjustment of shelf.

CADDY CORPORATION
509 Sharptown Road P.O. Box 345
Bridgeport, NJ 08014-0345
Tel: 856-467-4222 Fax: 856-467-5511
internet: www.caddycorp.com



SORTING CONVEYOR SV-10-10 SERIES



Specifications Continue:

BWF belt washer to consist of welded 16 gauge stainless steel. Belt washer to have top and bottom fan shaped sprays arranged so lukewarm water thoroughly washes all belt surfaces after which belt is wiped continuously. Belt washer to have hinged drop-down, splash proof stainless steel access door. Washer to be fitted with interconnected water pressure reducing valve, water pressure gauge, shutoff valve and thermostatically controlled mixing valve with check valves. Bottom of belt washer to have 1-1/2" drain with tailpiece and two removable stainless steel perforated scrap baskets. Belt washer piping to be complete with approved type vacuum breaker and check valve. All piping exposed to view to be chrome plated. Operation of belt washer to be controlled by solenoid valve integrally wired to time delay relay which is activated by palm switch of conveyor. Belt washer will operate for a period of 60 seconds after palm switch is released. A separate On/Off switch to be provided to permit operation of conveyor without belt washer.

Conveyor to be furnished with an 18 gauge stainless steel catch pan under full length of conveyor. Catch pan to be pitched towards belt washer.

SV-10-10 Conveyor Optional Features:

Direct Discharge onto Scrapping Trough

Scrapping trough to be of width to receive trays and provided with two rows of skatewheels with stainless steel bearings and spaced on approximately 2-1/4" centers.

Accumulating Table

Conveyor to be provided with integrally constructed 14 gauge stainless steel accumulating table at discharge end, size as shown on plan. All sides of table not abutting conveyor to have 3" curbing with 1-1/2" diameter 180 degree rolled rims and bull nosed corners. All horizontal intersections to be rounded. A cup strainer waste with 1-1/2" tailpiece to be provided.

Accumulating Table with extended drain

Waste outlet to be extended and to discharge into belt washer.

Belt Washer with Recirculating Water

BWR belt washer to consist of welded 16 gauge stainless steel. Belt washer to have top and bottom fan shaped sprays arranged so lukewarm water thoroughly washes all belt surfaces after which belt is wiped continuously. Belt washer to have hinged drop-down, splash proof stainless steel access door. Washer to be fitted with interconnected water pressure reducing valve, water pressure gauge, shutoff valve and thermostatically controlled mixing valve with check valves. Bottom of belt washer to have 1-1/2" drain with tailpiece and two removable stainless steel perforated scrap baskets, and removable constant overflow standpipe to maintain water level. A pump to be provided to recirculate water from reservoir through spray nozzles. Recirculating system to include a removable filter to facilitate cleaning. Operation of belt washer to be controlled by solenoid valve integrally wired to On/Off switch of

conveyor to provide automatic operation of belt washer while conveyor is running. A separate On/Off switch to be provided to permit operation of conveyor without belt washer.

Timed Belt Washing Cycle (for clean-up operations)

Belt washer to be controlled by automatic timer activated by a push button switch inside belt washer housing in such manner that conveyor and belt washer will operate without interruption for an adjustable cycle of up to 16 minutes. After completion of wash cycle conveyor is ready for next start-up.

Detergent Injector (for maximum sanitation)

A siphon type detergent injector working in conjunction with the belt washer water supply to be furnished.

Single Overhead Storage Shelf

Flat storage shelf to be constructed of 14 gauge stainless steel with shelf surface measuring 16" wide. Shelf to have turned down channel edge at front and 2" high riser at rear. Both ends to be fitted with 16" high "U" shaped rack supports made of 3/8" diameter stainless steel rod. Shelf to be attached to 12 gauge stainless steel cantilever brackets. Brackets to be welded to the underside of shelf. Plates and angles to have rows of conforming slots to permit front to back adjustment of shelf. Each bracket to be provided with two stainless steel truss head bolts and stainless steel nut.

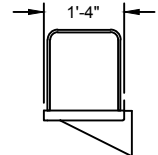

Mobile Bridge

Mobile bridge to be constructed of 14 gauge stainless steel type 301 seamlessly formed, welded, ground and polished to match the finish of the conveyor. Size to be as required. Three sides of bridge to have 1-1/2" diameter 180 degree rolled rims. Fourth side to be turned down over raised edge of scrapping trough. Bridge to be supported by 1-5/8" O.D. stainless steel legs with 1" O.D. stainless steel "H" railing completely welded and finished, and provided with 5" diameter casters with polyurethane tires and foot brakes. Stainless steel leg sleeves with set screws to facilitate vertical adjustment to be welded to underside of bridge.



CADDY CORPORATION

509 Sharptown Road P.O. Box 345
Bridgeport, NJ 08014-0345
Tel: 856-467-4222 Fax: 856-467-5511
internet: www.caddycorp.com

**SORTING CONVEYOR
SV-10-10 SERIES**



TYPICAL ROUGHING, PLUMBING AND ELECTRICAL DATA

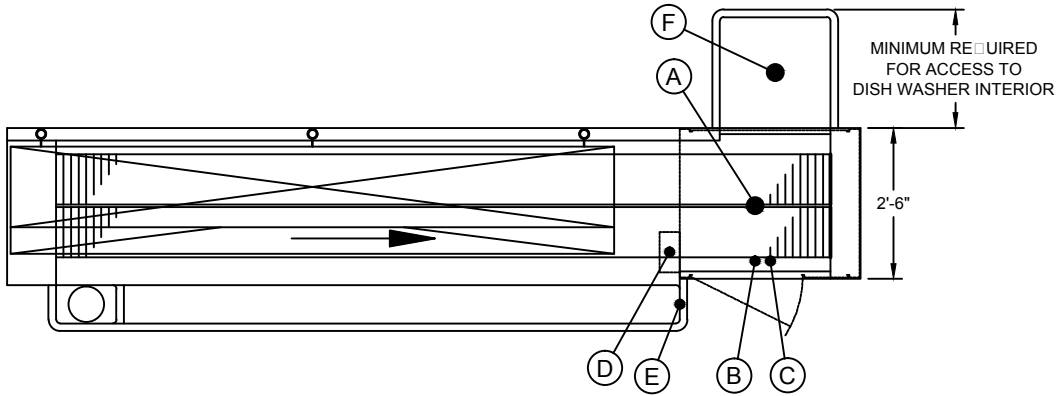

ROUGH-IN SCHEDULE	
NOTE: ALL ROUGH-INS TO BE 4" AFF	
SYM	DESCRIPTION
A	1 1/2" I.P.S. WASTE
B	1/2" I.P.S. HOT WATER
C	1/2" I.P.S. COLD WATER
D	1/2 H.P. (SEE BELOW FOR AVAILABLE ELEC. CHARACTERISTIC)
E	1/2" I.P.S. WATER INLET
F	1 1/2" I.P.S. WASTE (IF ACCUMULATING TABLE IS PROVIDED)

Motors available: 208/230/460 volts, 60 Hz, three phase. 120 volts, 60 Hz, single phase (for Sorting-Veyor up to 25 ft. long)

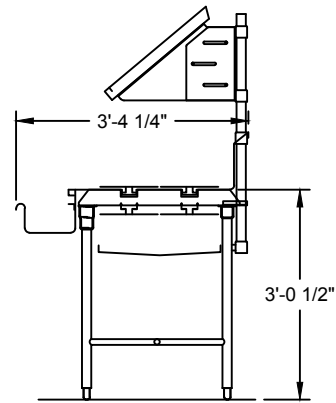

Typical Section View



BUSING CONVEYOR BV-10-10 SERIES

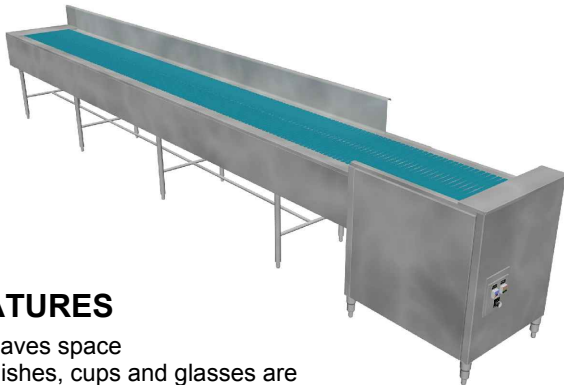

FEATURES

- Saves space
- Dishes, cups and glasses are sorted directly onto conveyor
- Tableware is conveyed to loading area of dish washer.

SPECIFICATIONS:

Series BV-10-10 Busing conveyor to be as manufactured by Caddy Corporation. U.L. and N.S.F. listed with labels affixed. Unit shall be as detailed on the plan and provided with two 10" self-tracking stainless steel chain-type belts resulting in 20" wide conveying surface. Conveyor belt to consist of a stainless steel chain having approximately 3/4" pitch with 10" side snap-on type slats. Slats to have tapered edges on all sides and molded of low friction polycarbonate compound and replaceable without the use of special tools and disassembling of belt chain. Slats not to overlap in any position to provide effective access of cleaning agents to all parts of the assembled belt. Return belt to be suspended from monorail-type track. Belt speed factory-set at approximately 20 feet per minute. Conveyor to be suitable for conveying stacked loose dishes, dishwasher racks, trays and similar items.

Conveyor bed to be 14 gauge stainless steel turned up adjacent to dishwashing machine to form 10" high curbing. Loading and unloading areas to have raised edges. Discharge end to be provided with palm operated switch wired so conveyor moves when switch is held in depressed position. Conveyor to have full length catch pan pitched to provide drainage.

Drive housing to consist of 18 gauge stainless steel enclosure on two sides with removable rear panel and opposite hinged access door with full height pull. Frame of drive housing to be 2"x2" angles stainless steel superstructure.

Rear sections of conveyor at belt return level to be provided with removable easy-to-lock-in-place skirting panels of 18 gauge stainless steel.

Busing conveyor to have stainless steel channel cross braces on approximately 5'-0" centers to be providing support under the bed and to the monorail belt return tracking system. Intermediate supports of the conveyor to consist of 1-5/8" O.D. stainless steel "H" frame legs with 1" O.D. stainless steel cross bracing completely welded, finished and provided with adjustable stainless steel bullet shaped feet.

Conveyor to be chain driven by reduction gearhead wash down type D.C. motor to eliminate high torque in case of jamming condition of the conveyor. Motor can also be

held in locked rotor position without damage to conveyor. All wired to the watertight SCR solid state D.C. controller. with overload protection, in NEMA 4 type enclosure. Positive action motor brake to be provided to stop conveyor without casting. Drive to be fitted with 20 gauge stainless steel 360° chain guard. All electrical components and motor to be conveniently located in the drive enclosure and completely interwired through splash proof flexible conduit and conduit connectors.

BWF belt washer to consist of welded 16 gauge stainless steel. Belt washer to have top and bottom fan shaped sprays arranged so lukewarm water thoroughly washes all belt surfaces after which belt is wiped continuously. Belt washer to have hinged drop-down, splash proof stainless steel access door. Washer to be fitted with interconnected water pressure reducing valve, water pressure gauge, shutoff valve and thermostatically controlled mixing valve with check valves. Bottom of belt washer to have 1-1/2" drain with tailpiece and two removable stainless steel perforated scrap baskets. Belt washer piping to be complete with approved type vacuum breaker and check valve. All piping exposed to view to be chrome plated. Operation of belt washer to be controlled by solenoid valve integrally wired to time delay relay which is activated by palm switch of conveyor. Belt washer will operate for a period of 60 seconds after palm switch is released. A separate On/Off switch to be provided to permit operation of conveyor without belt washer.

Conveyor to be furnished with an 18 gauge stainless steel catch pan under full length of conveyor. Catch pan to be pitched towards belt washer.

BV-10-10 Conveyor Optional Features:

Mobile Bv-10-10

Legs and housing to be fitted with heavy duty double ball bearing 5" dia. polyurethane tired swivel caster. Four end casters with brakes. Conveyor shall have 6'-0" long power cord. Water inlet of belt washer provided with heavy duty 6'-0" long rubber hose and quick disconnect shut-off coupling. A control box of 16 gauge stainless steel approximately 6 1/2" x 2-1/2" x 5-1/2" high with mounting tabs suitable for remote vertical installation to be furnished. Control box to contain a hot and cold water automatic temperature mixing valve with external adjustment, a water supply valve with external shut-off handle, a quick disconnect, 1/2" IPS hose coupler and two 1/2" IPS, hot and cold external male water inlets facing towards the floor for connection of hot and cold water supply by others.

Accumulating Table

Conveyor to be provided with integrally constructed 14 gauge stainless steel accumulating table at discharge end, size as shown on plan. All sides of table not abutting





BUSING CONVEYOR BV-10-10 SERIES



BV-10-10 Conveyor Optional Features:

conveyor to have 3" curbing with 1-1/2" diameter 180 degree rolled rims and bull nosed corners. All horizontal intersections to be rounded. A cup strainer waste with 1-1/2" tailpiece to be provided.

Accumulating Table with extended drain

Waste outlet to be extended and to be discharge into belt washer.

Belt Washer with Recirculating Water

BWR belt washer to consist of welded 16 gauge stainless steel. Belt washer to have top and bottom fan shaped sprays arranged so lukewarm water thoroughly washes all belt surfaces after which belt is wiped continuously. Belt washer to have hinged drop-down, splash proof stainless steel access door. Washer to be fitted with interconnected water pressure reducing valve, water pressure gauge, shutoff valve and thermostatically controlled mixing valve with check valves. Bottom of belt washer to have 1-1/2" drain with tailpiece and two removable stainless steel perforated scrap baskets, and removable constant overflow standpipe to maintain water level. A pump to be provided to recirculate water from reservoir through spray nozzles. Recirculating system to include a removable filter to facilitate cleaning. Operation of belt washer to be controlled by solenoid valve integrally wired to On/Off switch of conveyor to provide automatic operation of belt washer while conveyor is running. A separate On/Off switch to be provided to permit operation of conveyor without belt washer.

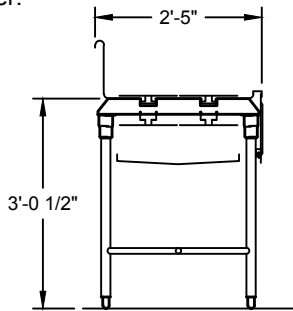

Typical Section View

TYPICAL ROUGHING, PLUMBING AND ELECTRICAL DATA

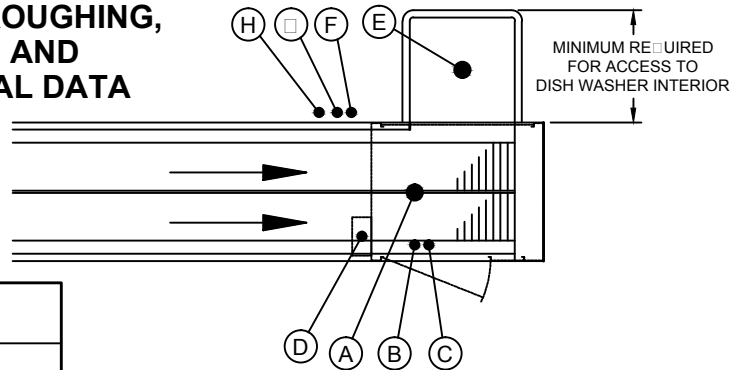

Timed Belt Washing Cycle (for clean-up operations)

Belt washer to be controlled by automatic timer activated by a push button switch inside belt washer housing in such manner that conveyor and belt washer will operate without interruption for an adjustable cycle of up to 16 minutes. After completion of wash cycle conveyor is ready for next start-up.

Detergent Injector (for maximum sanitation)

A pump type detergent injector working in conjunction with the belt washer water supply to be furnished.

Mobile Bridge

Mobile bridge to be constructed of 14 gauge stainless steel type 301 seamlessly formed, welded, ground and polished to match the finish of the conveyor. Size to be as required. Three sides of bridge to have 1-1/2" diameter 180 degree rolled rims. Fourth side to be turned down over raised edge of scrapping trough. Bridge to be supported by 1-5/8" O.D. stainless steel legs with 1" O.D. stainless steel "H" railing completely welded and finished, and provided with 5" diameter casters with polyurethane tires and foot brakes. Stainless steel leg sleeves with set screws to facilitate vertical adjustment to be welded to underside of bridge.



ROU □ H-IN SCHEDULE

NOTE: ALL ROU □ H-INS TO BE 4" AFF

SYM	DESCRIPTION
A	1 1/2" I.P.S. WASTE (FOR MOBILE UNIT PROVIDE 10" DIA. FUNNEL TOP-FLOOR DRAIN IN THIS LOCATION)
B	1/2" I.P.S. HOT WATER (FOR STATIONARY UNIT ONLY)
C	1/2" I.P.S. COLD WATER (FOR STATIONARY UNIT ONLY)
D	1/2" H.P. (FOR STATIONARY UNIT ONLY SEE BELOW FOR AVAILABLE ELECTRIC CHARACTERISTIC)
E	1 1/2" I.P.S. WASTE (IF ACCUMULATING TABLE IS PROVIDED, OPTIONAL)
F	1/2" H.P. (FOR MOBILE UNIT ONLY SEE BELOW FOR AVAILABLE ELECTRIC CHARACTERISTIC) PLUMBING RECEPTACLE SUPPLIED BY ELECTRICAL CONTRACTOR
□	1/2" I.P.S. HOT WATER (FOR MOBILE UNIT ONLY)
H	1/2" I.P.S. COLD WATER (FOR MOBILE UNIT ONLY)

Motors available: 208/230/460 volts, 60 Hz, three phase. 120 volts, 60 Hz, single phase (for Busing-Veyor up to 25 ft. long)

CADDY CORPORATION
 509 Sharptown Road P.O. Box 345
 Bridgeport, NJ 08014-0345
 Tel: 856-467-4222 Fax: 856-467-5511
 internet: www.caddycorp.com



CADDY CORPORATION

Food Service Equipment

Air Systems

Tray Make-Up
Conveyor
Systems



TRAY MAKE-UP CADDY-VEYOR "XL" SERIES



MODEL XL-1 SINGLE TRACK POWERED
recommended for institutions with 150 TO 400 BEDS

Labels in diagram: TRAY STARTER, COLD FOOD UNITS, MILK AND ICE CREAM DISPENSER, COFFEE AND MUG DISPENSER, HEATED PLATE DISPENSER, TRAY DELIVERY TRUCK, HOT FOOD UNITS, UNDERLINER DISPENSER, UTILITY CART, DOMED COVER DISPENSER.

Single track powered unit for time-saving tray completion in medium to moderately large institutions. Elevated conveyor bed reduces operating space, cuts down on stretching and turning to lessen fatigue.

Double track powered unit for maximum efficiency in large hospitals. Serves as two conveyors in one without requiring large extra floor space. Trays are served from both sides simultaneously, thus double tray production.

MODEL XL-2 DOUBLE TRACK POWERED
recommended for institutions with 400 TO 650 BEDS

Labels in diagram: HEATED PLATE DISPENSER, HOT FOOD UNITS, COLD FOOD UNIT, ICE CREAM & BEVERAGE DISPENSERS, COFFEE URN STAND, TOASTER CADDY & MUG DISPENSER, TRAY STARTERS, HEATED PLATE DISPENSER.

CADDY CORPORATION
509 Sharptown Road P.O. Box 345
Bridgeport, NJ 08014-0345
Tel: 856-467-4222 Fax: 856-467-5511
internet: www.caddycorp.com



TRAY MAKE-UP CADDY-VEYOR XL-1 SERIES

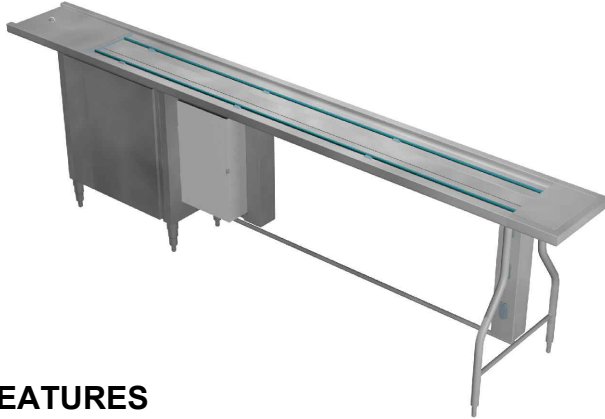

FEATURES

- Elevated design to accommodate tray assembly support equipment underneath, thereby saving 15-20% floor space as compared to conventional assembly lines.
- Single track powered unit for time-saving tray completion in medium to moderately large institutions.
- Elevated conveyor bed cuts down on stretching and turning to lessen fatigue.

SPECIFICATIONS:

Series XL-1 EXPRESS LINE Tray make-up conveyor to be as manufactured by Caddy Corporation Unit shall be 19" wide x _____ long, and to accommodate flat bottom trays up to 15" wide. (Specify dimensions of trays to be used.)

Conveyor belt to consist of dual 1/2" diameter Dura-San belting. Belting itself is USDA accepted, highly resistant to abrasion, dirt, oil and most chemicals, maintains tension without springs, sprockets or links, continuous without ends or mechanical connection devices. Start end to be provided with 6" long tray rest. Discharge end to have 20"

long tray pick-up area, with limit switch activated by stainless steel lever protruding through slot in belt bed. Belt to be driven only on top surface of conveyor bed. No drain pans. All bearings to be heavy duty ball-type, with sealed lubrication.

Conveyor bed to be 14 gauge stainless steel of welded construction, ground and polished. Conveyor bed height to be 42-1/2" and to be elevated over support equipment.

Structural supports to be stainless steel and welded to underside of conveyor bed. Conveyor to be provided with a screwed in place access panel at tail end providing access to bearings.

Drive housing to consist of 18 gauge stainless steel enclosure on two sides with removable 18 gauge panels. Conveyor belt to direct drive by variable speed motor with range of belt speed 5 to 40 feet per minute rated for 120/208/60/3 phase, 4 wire plus separate ground. Motor to be controlled manually through an on/off push-button switch and automatically through a limit switch, both located at discharge end. All wired to splashproof SCR controller with low voltage and overload protection. All electrical components above, as well as the motor, to be completely interwired through waterproof flex conduit and splashproof conduit connectors, terminating in waterproof circuit breaker panel(s).

Leg assembly of 16 gauge tubular stainless steel 1 5/8" O.D. and 1" O.D. crossbracing completely welded.

(Continue specifications by selecting stationary or mobile model)

Stationary Unit

Fitted with adjustable stainless steel bullet feet.

Mobile Unit

Fitted with 5" diameter polyurethane tired casters, two with brakes. Conveyor shall have 6'-0" long power cord.

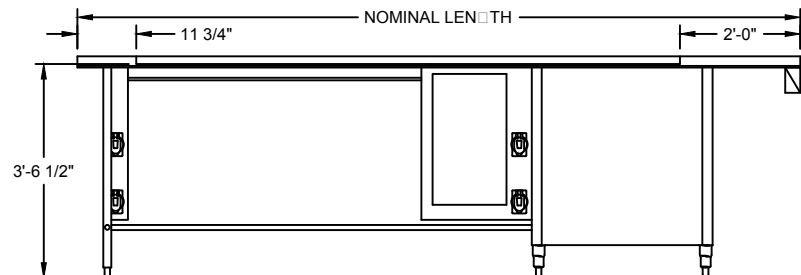
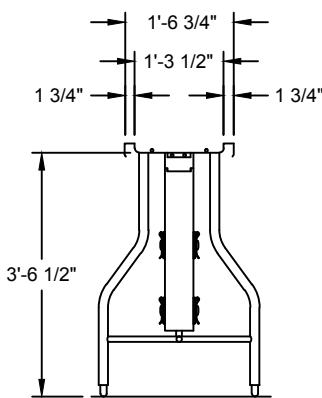

CADDY CORPORATION
 509 Sharptown Road P.O. Box 345
 Bridgeport, NJ 08014-0345
 Tel: 856-467-4222 Fax: 856-467-5511
 internet: www.caddycorp.com



TRAY MAKE-UP CADDY-VEYOR XL-1 SERIES



Optional Features:

Wireway with Factory Installed Electric Outlets

Caddy-veyor to be furnished with a stainless steel wireway recessed under conveyor bed with removable screw cover. Wireway will distribute to power risers located at each leg assembly. Both sides of power riser to be provided with moisture-proof electric outlets with hinged covers for adjoining mobile equipment, all as indicated on plan. Outlets wired to one or more circuit breaker panels with each receptacle having its own circuit breaker control with manual reset feature and shut-off. All electrical work to be ready for single final connection by others to a circuit breaker panel at the job site.

Specify number of outlets, as well as voltage, phase, wattage or motor size and location for each electrical plug-in outlet required. Preferred input voltage is 120/208v, 3ph, 5 wire system including ground.

IMPORTANT NOTE ON ELECTRICAL DATA

Maximum allowable amperage for mobile tray make-up conveyor is 100 amps 3 phase. If total amperage exceeds 100 amp, 3 phase, a second circuit breaker panel will be required. A separate electrical connection is needed in the field for EACH circuit breaker panel on the conveyor.

Removable Work and Storage Shelf for Advance Make-Up of Soup and Beverages

Work and storage shelf to be **Model ACC-2010** made of 16 gauge stainless steel flanged up at rear and both sides. Shelf supported by stainless steel tubular leg with adjustable stainless steel bullet foot. Shelf size to be 20" x 10". Rear of shelf to be contoured to fit over and slide along curbing of conveyor and provided with positive locking clip to engage lower edge of conveyor bed.

Double Overshelf for Storage of Cookies, Crackers, Desserts, etc.

Double overshelf to be **Model ACC-6015** and to set on curbing of conveyor. To be approximately 5'-0" long with two shelves 15" wide of 16 gauge stainless steel turned down 1" on all four sides, supported by splayed legs of 1" O.D. 16 gauge stainless steel tubing with guides at bottom to slide to any convenient location.

Overhead Starter Shelf

Overhead tray starter shelf to be **Model T-565** and to set on curbing of conveyor. To be approximately 3'-0" long with sloped shelf of 16 gauge stainless steel turned down 1" on front and back. Cutout in shelf to accommodate three pans 4" deep. Mounted on legs of 1" O.D. 16 gauge stainless steel tubing with guides at bottom to slide to any convenient location.

Undermount Starter Shelf

Undermount tray starter shelf to be **Model T-566** and to be mounted under conveyor bed with two 14 gauge stainless steel brackets. To be approximately 3'-0" long with sloped shelf of 16 gauge stainless steel turned down 1" on front and back. Cutout in shelf to accommodate three pans 4" deep.

Stainless Steel Pans

A set of 3 stainless steel pans (one full, two 1/3 pan) for T-565 or T-566

Stationary Conveyor

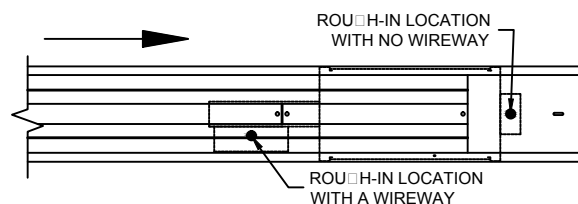

Sketches shown are for general layout purposes only, subject to changes without prior notice consistent with latest design changes. For final dimensional and roughing data, special drawings applicable to a specific order should be requested from Caddy Engineering Department.





TRAY MAKE-UP CADDY-VEYOR XL-2 SERIES



FEATURES

- Serves as two conveyors in one without requiring extra large floor space.
- Double track powered unit for maximum efficiency in large institutions.
- Elevated conveyor bed cuts down on stretching and turning to lessen fatigue.

SPECIFICATIONS:

Series XL-2 EXPRESS LINE Tray make-up conveyor to be as manufactured by Caddy Corporation Unit shall be 36 1/4" wide x _____ long, and to accommodate flat bottom trays up to 15" wide. (Specify dimensions of trays to be used.)

Conveyor belt to consist of dual 1/2" diameter Dura-San belting. Belting itself is USDA accepted, highly resistant to abrasion, dirt, oil and most chemicals, maintains tension without springs, sprockets or links, continuous without ends or mechanical connection devices. Start end to be provided with 6" long tray rest. Discharge end to have 20" long tray pick-up area, with limit switch activated by stainless steel lever protruding through slot in belt bed. Belt

to be driven only on top surface of conveyor bed. No drain pans. All bearings to be heavy duty ball-type, with sealed lubrication.

Conveyor bed to be 14 gauge stainless steel of welded construction, ground and polished. Conveyor bed height to be 42-1/2" and to be elevated over support equipment.

Structural Supports to be stainless steel and welded to underside of conveyor bed. Conveyor to be provided with a screwed in place access panel at tail end providing access to bearings.

Drive housing to consist of 18 gauge stainless steel enclosure on two sides with removable 18 gauge panels.

Conveyor belt to be direct drive by variable speed motor with range of belt speed 5 to 40 feet per minute rated for 120/208/60/3 phase, 4 wire plus separate ground.

Motor to be controlled manually through an on/off push-button switch and automatically through a limit switch, both located at discharge end. All wired to splashproof SCR controller with low voltage and overload protection. All electrical components above, as well as the motor, to be completely interwired through waterproof flex conduit and splashproof conduit connectors, terminating in waterproof circuit breaker panel(s).

Leg assembly of 16 gauge tubular stainless steel 1 5/8" O.D. and 1" O.D. crossbracing completely welded.

(Continue specifications by selecting stationary or mobile model)

Stationary Unit

Fitted with adjustable stainless steel bullet feet.

Mobile Unit

Fitted with 5" diameter polyurethane tired casters, two with brakes. Conveyor shall have 6'-0" long power cord.

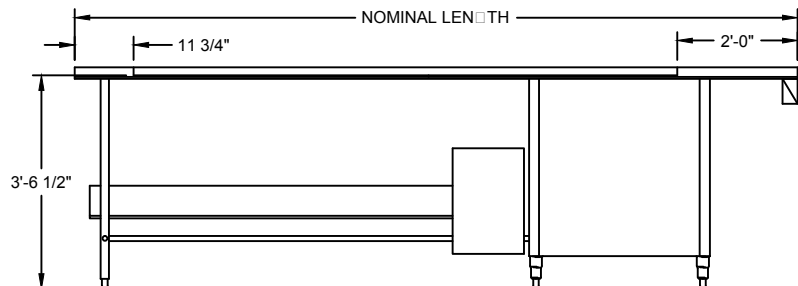
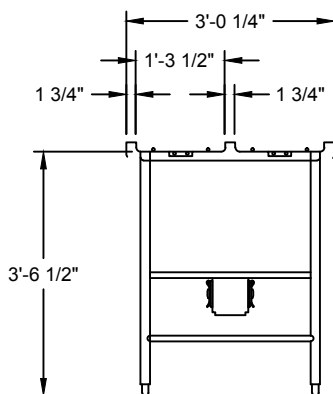

CADDY CORPORATION
 509 Sharptown Road P.O. Box 345
 Bridgeport, NJ 08014-0345
 Tel: 856-467-4222 Fax: 856-467-5511
 internet: www.caddycorp.com



TRAY MAKE-UP CADDY-VEYOR XL-2 SERIES



Optional Features:

Wireway with Factory Installed Electric Outlets

Caddy-veyor to be furnished with a recessed stainless steel wireway and electric outlets with hinged moisture proof covers for adjoining mobile equipment on both sides, all as indicated on plans. Outlets wired to one or more circuit breaker panels with each receptacle having its own circuit breaker control with manual reset feature and shut-off. All electrical work to be ready for single final connection by others to a circuit breaker panel at the job site.

Specify number of outlets, as well as voltage, phase, wattage or motor size and location for each electrical plug-in outlet required. Preferred input voltage is 120/208v, 3ph, 5 wire system including ground.

IMPORTANT NOTE ON ELECTRICAL DATA

Maximum allowable amperage for mobile tray make-up conveyor is 100 amps 3 phase. If total amperage exceeds 100 amp, 3 phase, a second circuit breaker panel will be required. A separate electric connection is needed in the field for EACH circuit breaker panel on the conveyor.

Removable Work and Storage Shelf for Advance Make-Up of Soup and Beverages

Work and storage shelf to be **Model ACC-2010** made of 16 gauge stainless steel flanged up at rear and both sides. Shelf supported by stainless steel tubular leg with adjustable stainless steel bullet foot. Shelf size to be 20" x 10". Rear of shelf to be contoured to fit over and slide along curbing of conveyor and provided with positive locking clip to engage lower edge of conveyor bed.

Double Overshelf for Storage of Cookies, Crackers, Desserts, etc.

Double overshelf to be **Model ACC-6015** and to set on curbing of conveyor. To be approximately 5'-0" long with two shelves 15" wide of 16 gauge stainless steel turned down 1" on all four sides, supported by splayed legs of 1" O.D. 16 gauge stainless steel tubing with guides at bottom to slide to any convenient location.

Overhead Starter Shelf

Overhead tray starter shelf to be **Model T-565** and to set on curbing of conveyor. To be approximately 3'-0" long with sloped shelf of 16 gauge stainless steel turned down 1" on front and back. Cutout in shelf to accommodate three pans 4" deep. Mounted on legs of 1" O.D. 16 gauge stainless steel tubing with guides at bottom to slide to any convenient location.

Undermount Starter Shelf

Undermount tray starter shelf to be **Model T-566** and to be mounted under conveyor bed with two 14 gauge brackets. To be approximately 3'-0" long with sloped shelf of 16 gauge stainless steel turned down 1" on front and back. Cutout in shelf to accommodate three pans 4" deep.

Stainless Steel Pans

A set of 3 stainless steel pans (one full, two 1/3 pans) for T-565 or T-566

Stationary Conveyor

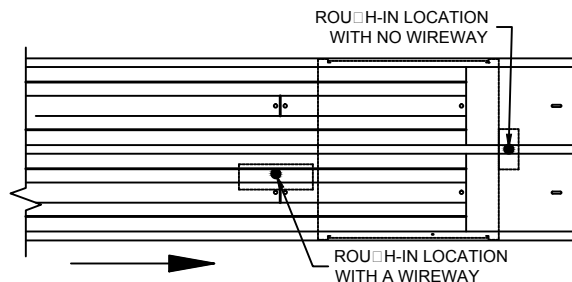

Sketches shown are for general layout purposes only, subject to changes without prior notice consistent with latest design changes. For final dimensional and roughing data, special drawings applicable to a specific order should be requested from Caddy Engineering Department.

CADDY CORPORATION
 509 Sharptown Road P.O. Box 345
 Bridgeport, NJ 08014-0345
 Tel: 856-467-4222 Fax: 856-467-5511
 internet: www.caddycorp.com



**TRAY MAKE-UP CADDY-VEYOR
XL-1C PRISON PACKAGE**



FEATURES

- No parts can be removed.
- No concealed places to store contraband
- All exposed fasteners are heavy duty stainless steel tamper-proof fasteners.
- Elevated designed to accommodate tray assembly support equipment underneath, thereby saving 15-20^{sq} floor space as compared to conventional assembly lines.
- Single track powered unit for time-saving tray completion in medium to moderately large institutions.
- Elevated conveyor bed cuts down on stretching and turning to lessen fatigue.

SPECIFICATIONS:

Series XL-1C PRISON LINE Tray make-up conveyor to be as manufactured by Caddy Corporation Unit shall be 19" wide x _____ long, and to accommodate flat bottom trays up to 15" wide. (Specify dimensions of trays to be used.)

Conveyor belt to consist of dual 1/2" diameter Dura-San belting. Belting itself is USDA accepted, highly resistant to abrasion, dirt, oil and most chemicals, maintains tension without springs, sprockets or links, continuous without ends or mechanical connection devices. Start end to be provided with 6" long tray rest. Discharge end to have 20"

long tray pick-up area, with limit switch activated by stainless steel lever protruding through slot in belt bed. Belt to be driven only on top surface of conveyor bed. No drain pans. All bearings to be heavy duty ball-type, with sealed lubrication.

Conveyor bed to be 14 gauge stainless steel of welded construction, ground and polished. Legs to be 16 gauge tubular stainless steel 1-5/8" O.D. with 1" O.D. crossbracing completely welded. Conveyor bed height to be 42-1/2" and to elevated over support equipment.

Structural supports to be stainless steel and welded to underside of conveyor bed. Conveyor to be provided with an access panel at tail end providing access to bearings. Panel to be screwed in place with tamper-proof stainless steel security screws.

Drive housing to consist of 18 gauge stainless steel enclosure on two sides with removable 18 gauge panels. Panels to be fastened with tamper-proof stainless steel security screws. Housing to have 6 1/2" high adjustable stainless steel feet. Bottom of housing to have perforated stainless steel panel welded in place. No place to store contraband will be allowed.

Conveyor belt to direct drive by variable speed motor with range of belt speed 5 to 40 feet per minute rated for 120/208/60/3 phase, 4 wires plus separate ground.

Motor to be controlled manually through an on/off push-button switch and automatically through a limit switch, both located at discharge end. All wired to splashproof SCR controller with low voltage and overload protection. All controls and wiring to be protected from disassembly and unauthorized adjustments.

(Continue specifications by selecting stationary or mobile model)

Mobile Unit

Fitted with 5" diameter polyurethane tired casters, two with brakes. Conveyor shall have 6'-0" long power cord.

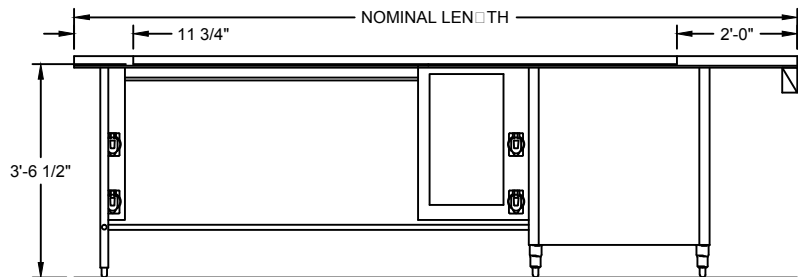
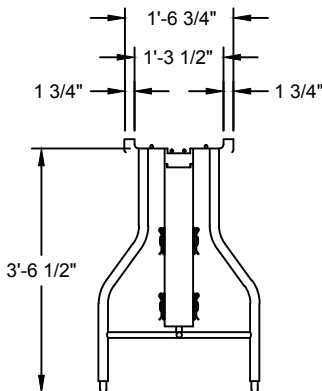

CADDY CORPORATION
 509 Sharptown Road P.O. Box 345
 Bridgeport, NJ 08014-0345
 Tel: 856-467-4222 Fax: 856-467-5511
 internet: www.caddycorp.com



TRAY MAKE-UP CADDY-VEYOR XL-1C PRISON PACKAGE



Optional Features:

Wireway with Factory Installed Electric Outlets

Caddy-veyor to be furnished with a stainless steel wireway recessed under conveyor bed with removable screw cover. Wireway will distribute to power risers located at each leg assembly. Both sides of power riser to be provided with moisture-proof electric outlets with hinged covers for adjoining mobile equipment, all as indicated on plan. Outlets wired to one or more circuit breaker panels with each receptacle having its own circuit breaker control with manual reset feature and shut-off. All wireway fasteners and receptacle fasteners to be heavy duty tamper-proof stainless steel security type. All electrical work to be ready for single final connection by others to a circuit breaker panel at the job site.

Specify number of outlets, as well as voltage, phase, wattage or motor size and location for each electrical plug-in outlet required. Preferred input voltage is 120/208v, 3ph, 5 wire system including ground.

IMPORTANT NOTE ON ELECTRICAL DATA

If total amperage exceeds 100 amp, 3phase, a second circuit breaker panel may be required. For mobile tray make-up conveyor the maximum allowable amperage for each circuit breaker panel with 6'-0" cord and plug is 100 amps. A separate electrical connection is needed in the field for EACH circuit breaker panel on the conveyor.

Removable Work and Storage Shelf for Advance Make-Up of Soup and Beverages

Work and storage shelf to be **Model ACC-2010** made of 16 gauge stainless steel flanged up at rear and both sides.

Shelf supported by stainless steel tubular legs with adjustable stainless steel bullet foot. Shelf size to be 20" x 10". Rear of shelf to be contoured to fit over and slide along curbing of conveyor and provided with positive locking clip to engage lower edge of conveyor bed.

Double Overshelf for Storage of Cookies, Crackers, Desserts, etc.

Double overshelf to be **Model ACC-6015** and to set on curbing of conveyor. To be approximately 5'-0" long with two shelves 15" wide of 16 gauge stainless steel turned down 1" on all four sides, supported by splayed legs of 1" O.D. 16 gauge stainless steel tubing with guides at bottom to slide to any convenient location.

Overhead Starter Shelf

Overhead tray starter shelf to be **Model T-565** and to set on curbing of conveyor. To be approximately 3'-0" long with sloped shelf of 16 gauge stainless steel turned down 1" on front and back. Cutout in shelf to accommodate three pans 4" deep. Mounted on legs of 1" O.D. 16 gauge stainless steel tubing with guides at bottom to slide to any convenient location.

Undermount Starter Shelf

Undermount tray starter shelf to be **Model T-566** and to be mounted under conveyor bed with two 14 gauge brackets. To be approximately 3'-0" long with sloped shelf of 16 gauge stainless steel turned down 1" on front and back. Cutout in shelf to accommodate three pans 4" deep.

Stainless Steel Pans

A set of 3 stainless steel pans (one full, two 1/3 pans) for T-565 or T-566

Stationary Conveyor

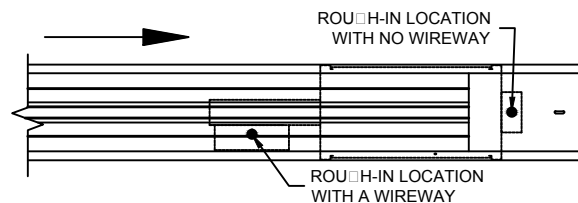

Sketches shown are for general layout purposes only, subject to changes without prior notice consistent with latest design changes. For final dimensional and roughing data, special drawings applicable to a specific order should be requested from Caddy Engineering Department.

CADDY CORPORATION
509 Sharptown Road P.O. Box 345
Bridgeport, NJ 08014-0345
Tel: 856-467-4222 Fax: 856-467-5511
internet: www.caddycorp.com



TRAY MAKE-UP CADDY-VEYOR NON-POWERED XL-S



This superior non-powered unit brings a cost cutting tray make-up system to small hospitals and nursing homes. Affords the most sophisticated method of achieving economy and simplicity of operation. Non-mechanized, non powered, utilizing the skatewheel principle of tray movement.

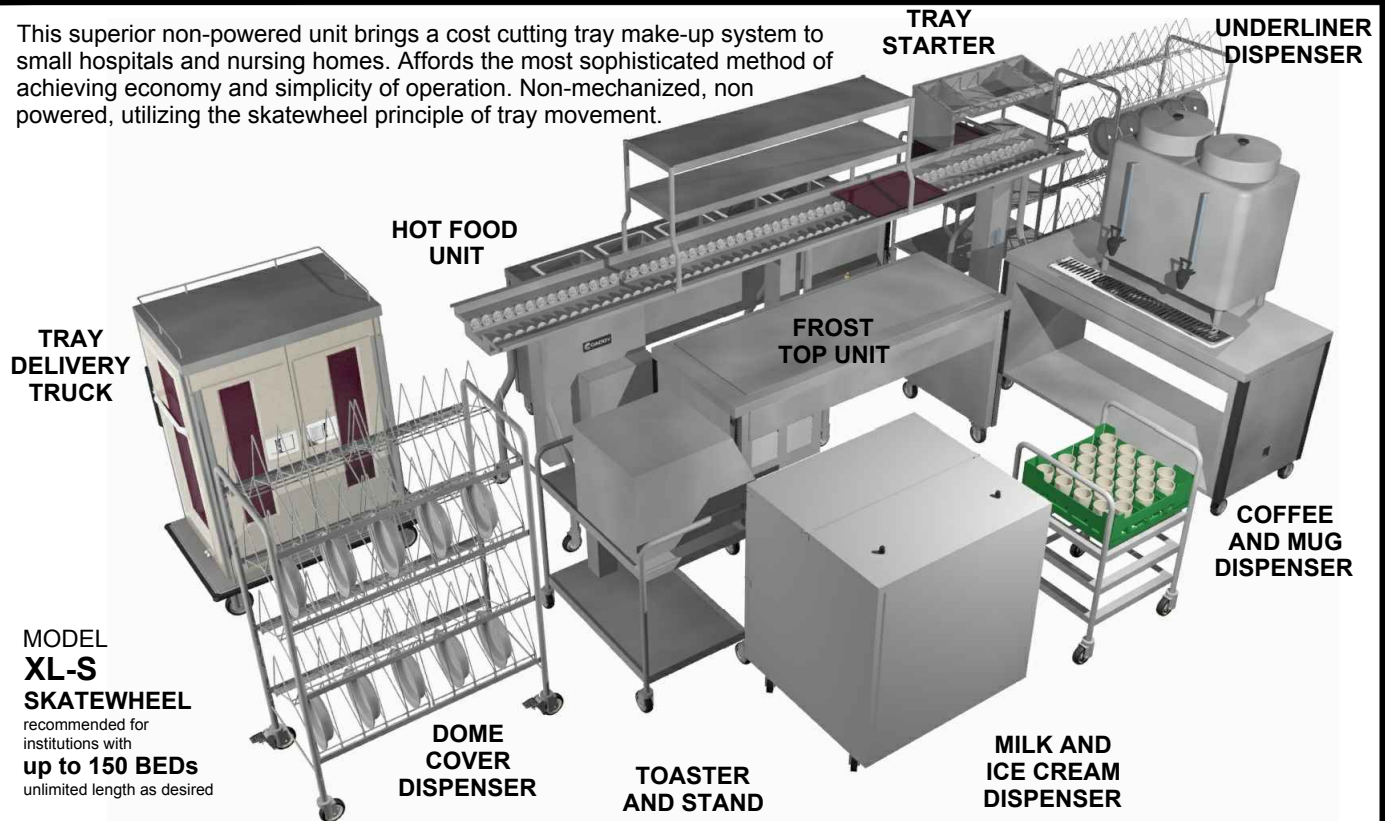

MODEL
XL-S
SKATEWHEEL
recommended for
institutions with
up to 150 BEDs
unlimited length as desired

FEATURES

- Most economical non-mechanized, non-powered Caddy-veyor. Use only for flat bottom trays. (Not used for trays with irregular bottoms).

Specification:

Series XL-S Skatewheel tray make-up conveyor to be as manufactured by Caddy Corporation. Unit shall be 19 1/4" wide x _____ long, and to accommodate flat bottom trays up to 16" wide. (Specify dimensions of trays to be used.)

Conveyor bed to have two rows of 1.9" O.D. plastic skatewheels with stainless steel ball bearings spaced on approximately 2-1/4" centers and mounted with stainless steel hardware. Conveyor to be provided with 16 gauge stainless steel bed of welded construction, ground and

polished. Conveyor bed height to be 42-1/2" and to be elevated over support equipment. Both longitudinal curbings for conveyor bed to have channeled edges with 1" turndown and extending 1-1/2" above the top of the skatewheels. Structural supports to be stainless steel and welded to underside of conveyor bed. Each end of conveyor bed to be provided with tray stop and hand lift access with bed cleanout provision.

Leg assembly of 16 gauge tubular stainless steel 1 5/8" O.D. and 1" O.D. crossbracing completely welded.

(Continue specifications by selecting stationary or mobile model)

Stationary Unit

Fitted with adjustable stainless steel bullet feet.

Mobile Unit

Fitted with 5" diameter polyurethane tired casters, two with brakes. Conveyor shall have 6'-0" long power cord.

CADDY CORPORATION
509 Sharptown Road P.O. Box 345
Bridgeport, NJ 08014-0345
Tel: 856-467-4222 Fax: 856-467-5511
internet: www.caddycorp.com

TRAY MAKE-UP CADDY-VEYOR NON-POWERED XL-S

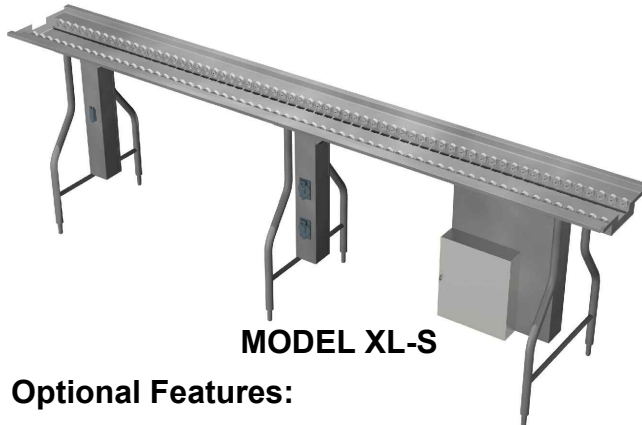

MODEL XL-S

Optional Features:

Wireway with Factory Installed Electric Outlets

Caddy-veyor to be furnished with a stainless steel wireway recessed under conveyor bed with removable screw cover. Wireway will distribute to power risers located at each leg assembly. Both sides of power riser to be provided with moisture-proof electric outlets with hinged covers for adjoining mobile equipment, all as indicated on plan. Outlets wired to one or more circuit breaker panels with each receptacle having its own circuit breaker control with manual reset feature and shut-off. All electrical work to be ready for single final connection by others to a circuit breaker panel at the job site.

Specify number of outlets, as well as voltage, phase, wattage or motor size and location for each electrical plug-in outlet required. Preferred input voltage is 120/208v, 3ph, 5 wire system including ground.

IMPORTANT NOTE ON ELECTRICAL DATA

Maximum allowable amperage for mobile tray make-up conveyor is 100 amps 3 phase. If total amperage exceeds 100 amp, 3 phase, a second circuit breaker panel will be required. A separate electrical connection is needed in the field for EACH circuit breaker panel on the conveyor.

Double Overshelf for Storage of Cookies, Crackers, Desserts, etc.

Double overshelf to be **Model ACC-6015** and to set on curbing of conveyor. To be approximately 5'-0" long with two shelves 15" wide of 16 gauge stainless steel turned down 1" on all four sides, supported by splayed legs of 1" O.D. 16 gauge stainless steel tubing with guides at bottom to slide to any convenient location.

Overhead Starter Shelf

Overhead tray starter shelf to be **Model T-565** and to set on curbing of conveyor. To be approximately 3'-0" long with sloped shelf of 16 gauge stainless steel turned down 1" on front and back. Cutout in shelf to accommodate three pans 4" deep. Mounted on legs of 1" O.D. 16 gauge stainless steel tubing with guides at bottom to slide to any convenient location.

Undermount Starter Shelf

Undermount tray starter shelf to be **Model T-566** and to be mounted under conveyor bed with two 14 gauge brackets. To be approximately 3'-0" long with sloped shelf of 16 gauge stainless steel turned down 1" on front and back. Cutout in shelf to accommodate three pans 4" deep.

Stainless Steel Pans

A set of 3 stainless steel pans (one full, two 1/3 pans) for T-565 or T-566

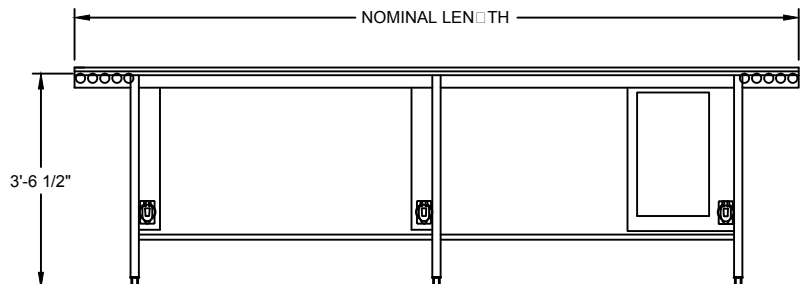
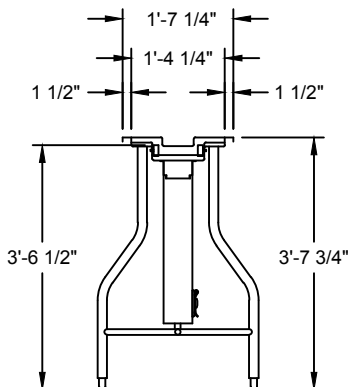

CADDY CORPORATION
 509 Sharptown Road P.O. Box 345
 Bridgeport, NJ 08014-0345
 Tel: 856-467-4222 Fax: 856-467-5511
 internet: www.caddycorp.com

TRAY MAKE-UP CADDY-VEYOR NON-POWERED XL-R



FEATURES

- Heavy duty deluxe tray make-up Roller-veyor, will handle any type trays (flat bottom or irregular bottom). Non-mechanized, non-powered.

Specification:

Series XL-R Roller tray make-up conveyor to be as manufactured by Caddy Corporation. Unit shall be 19-1/4" wide x _____ long, and to accommodate trays up to 16" wide. (Specify dimensions of trays to be used.)

Conveyor bed to have a single row of full width 1-1/4" O.D. plastic rollers with stainless steel balls in nylon bearings, spaced on approximately 3" centers with stainless steel hardware. Conveyor to be provided with 16 gauge stainless steel bed of welded construction, ground and polished. Conveyor bed height to be 42-1/2" and to be elevated over support equipment. Both longitudinal curbing for conveyor bed to have channeled edges with 1" turndown and extending 1-1/2" above the top of the skatewheels. Structural supports to be stainless steel and welded to underside of conveyor bed. Each end of conveyor bed to be provided with tray stop and hand lift access with bed cleanout provision.

Leg assembly of 16 gauge tubular stainless steel 1 5/8" O.D. and 1" O.D. crossbracing completely welded.

(Continue specifications by selecting stationary or mobile model)

Stationary Unit

Fitted with adjustable stainless steel bullet feet.

Mobile Unit

Fitted with 5" diameter polyurethane tired casters, two with brakes. Conveyor shall have 6'-0" long power cord if optional is included with conveyor.

Optional Features:

1-1/4" O.D. Spring Loaded Plastic Rollers

Provide single row of full width 1-1/4" O.D. plastic rollers with stainless steel balls in nylon bearings, spaced at approximately 3" centers with stainless steel spring loaded hexagon snap-in shafts.

Wireway with Factory Installed Electric Outlets

Caddy-veyor to be furnished with a stainless steel wire way recessed under conveyor bed with removable screw cover. Wireway will distribute to power risers located at each leg assembly. Both sides of power riser to be provided with moisture-proof electrical outlets with hinged covers for adjoining mobile equipment, all as indicated on plan. Outlets wired to one or more circuit breaker panels with each

receptacle having its own circuit breaker control with manual reset feature and shut-off. All electrical work to be ready for single final connection by others to a circuit breaker panel at the job site.

Specify number of outlets, as well as voltage, phase, wattage or motor size and location for each electrical plug-in outlet required. Preferred input voltage is 120/208v, 3ph, 5 wire system including ground.

IMPORTANT NOTE ON ELECTRICAL DATA

Maximum allowable amperage for mobile tray make-up conveyor is 100 amps 3 phase. If total amperage exceeds 100 amp, 3 phase, a second circuit breaker panel will be required. A separate electrical connection is needed in the field for EACH circuit breaker panel on the conveyor.

Double Overshelf for Storage of Cookies, Crackers, Desserts, etc.

Double overshelf to be **Model ACC-6015** and to set on curbing of conveyor. To be approximately 5'-0" long with two shelves 15" wide of 16 gauge stainless steel turned down 1" on all four sides, supported by splayed legs of 1" O.D. 16 gauge stainless steel tubing with guides at bottom to slide to any convenient location.

Overhead Starter Shelf

Overhead tray starter shelf to be **Model T-565** and to set on curbing of conveyor. To be approximately 3'-0" long with sloped shelf of 16 gauge stainless steel turned down 1" on front and back. Cutout in shelf to accommodate three pans 4" deep. Mounted on legs of 1" O.D. 16 gauge stainless steel tubing with guides at bottom to slide to any convenient location.

Undermount Starter Shelf

Undermount tray starter shelf to be **Model T-566** and to be mounted under conveyor bed with two 14 gauge brackets. To be approximately 3'-0" long with sloped shelf of 16 gauge stainless steel turned down 1" on front and back. Cutout in shelf to accommodate three pans 4" deep.

Stainless Steel Pans

A set of 3 stainless steel pans (one full, two 1/3 pans) for T-565 or T-566

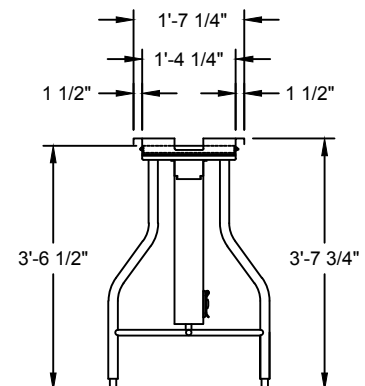



TRAY MAKE-UP CADDY-VEYOR TM-10 SERIES



SPECIFICATIONS:

Series TM-10 Tray Make-Up Conveyor to be as manufactured by Caddy Corporation, of length as indicated on plan and for trays up to 17 1/2" wide. Conveyor to be U.L. and N.S.F. listed with labels affixed.

Conveyor belt to consist of a stainless steel chain having approximately 3/4" pitch with 10" wide snap-on slats. Slats to have tapered edges on all sides and molded with integral hold-down tabs. Slats of low friction polycarbonate compound replaceable without the use of special tools and disassembling of belt chain. Slats not to overlap in any position to provide effective access of cleaning agents to all parts of the assembled belt and conveyor bed. Start end to be provided with 12" long tray rest. Discharge end to have 24" long tray pickup area, with limit switch activated by stainless steel lever protruding through slot in belt bed. All bearings to be heavy duty ball type, with sealed lubrication.

Caddy-veyor bed to be constructed of 14 gauge stainless steel Type 301 with all edges turned down into 2" wide channels. Top of bed at longitudinal edges to be raised. All joints to be continuously welded, ground and polished. Between the drive and tail ends, unit to have 3-1/2" wide stainless steel channel bracing on approximately 5'-0" centers. Conveyor to be provided with stainless steel catch pan running the full length and pitched to beltwasher.

Conveyor to be enclosed on both sides by full length skirting approximately 12" high consisting of removable 18 gauge stainless steel panels to provide full access.

Drive housing to consist of 18 gauge stainless steel enclosure on two sides with removable rear panel and opposite hinged access door with full height pull. Housing to set on 6-1/2" high adjustable stainless steel feet. Balance of conveyor to be supported by 1-5/8" O.D. stainless steel legs with adjustable stainless steel feet and welded 1" O.D. stainless steel lateral and longitudinal braces. Conveyor to be chain driven by variable speed motor with range of belt speed 0 to 40 feet per minute rated for 120/208/60/3 phase, 4 wire plus separate ground.

Motor to be controlled manually through an on/off push button switch and automatically through a limit switch, both located at discharge end. All wired to splash proof SCR controller with low voltage and overload protection. All electrical components above, as well as the motor to be conveniently located in drive enclosure and to be completely inter wired through waterproof flexible conduit and splash proof circuit connectors.

Caddy-veyor to be furnished with a recessed stainless steel wireway and electric outlets with hinged moisture proof covers for adjoining mobile equipment on both sides, all as

indicated on plan. Outlets wired to one or more circuit breaker panels with each receptacle having its own circuit breaker control with manual reset feature and shut-off. All electrical work to be ready for single final connection by others to a circuit breaker panel at the job site.

Specify number of outlets, as well as voltage, phase, wattage or motor size and location for each electrical plug-in outlet required. Preferred input voltage is 120/208v, 3ph, 5 wire system including ground.

Fresh Water Beltwasher:

Provide a welded 16 gauge stainless steel beltwasher **Model BWF** with top and bottom fan shaped sprays arranged so lukewarm water thoroughly washes all belt surfaces after which belt is wiped continuously. Beltwasher to have hinged drop-down splash proof stainless steel access door. Washer to be fitted with interconnected water pressure reducing valve, water pressure gauge, shutoff valve and thermostatically controlled mixing valve with check valves. Bottom of beltwasher to have 1-1/2" drain with tailpiece and two removable stainless steel perforated scrap basket. Beltwasher piping to be complete with approved type vacuum breaker and check valve. All piping exposed to view to be chrome plated.

(for conveyor over 24 feet long, add the following paragraph)

Auxiliary drain to be provided near start end of conveyor to obtain proper pitch of drain pan.

(for conveyor with a turn, add the following paragraph)

Conveyor to be of configuration as shown on plan. Curved section to have positive hold-down tracks made of non-metallic material at least 1/2" thick with built-in solid lubricant for continuous lubrication of conveyor belt. Materials which transmit heat due to high friction and resistance are not acceptable. Belt capable of movement through a turn of 22" (standard) radius to the center of the conveyor belt. (Other radii available upon request.)

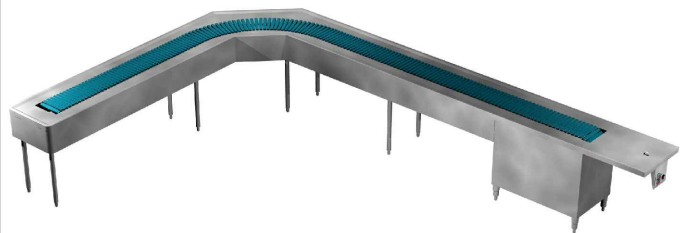

Model with turn should be specified where building limitations or obstacles prohibit the use of a straight conveyor. May be specified in L-shaped, U-shaped, serpentine or practically any shape. Can't go straight:

Specify **Model TM-10 with turns**



CADDY CORPORATION

509 Sharptown Road P.O. Box 345
Bridgeport, NJ 08014-0345
Tel: 856-467-4222 Fax: 856-467-5511
internet: www.caddycorp.com



TRAY MAKE-UP CADDY-VEYOR TM-10 SERIES



(Continue specifications, indicating applicable service)

Optional Features:

Automatic Water Saver Control for Fresh Water Beltwasher

Operation of beltwasher to be controlled by solenoid valve integrally wired to on/off switch of conveyor to provide automatic operation of beltwasher while conveyor is running. A separate on/off switch to be provided to permit operation of conveyor without beltwasher.

Beltwasher with Recirculating Water

(Recommended for reduction of water consumption and / or in conjunction with detergent injection.)

Provide a welded 16 gauge stainless steel beltwasher **Model BWR** with top and bottom fan shaped sprays arranged so lukewarm water thoroughly washes all belt surfaces after which belt is wiped continuously. Beltwasher to have hinged drop-down splash proof stainless steel access door. Washer to be fitted with interconnected water pressure reducing valve, water pressure gauge, shutoff valve and thermostatically controlled mixing valve with check valves. Bottom of beltwasher to have two removable stainless steel perforated scrap baskets and 1-1/2" drain with tailpiece and removable constant overflow standpipe to maintain water level. A pump to be provided to recirculate water from reservoir through spray nozzles. Recirculating system to include a removable filter to facilitate cleaning. Operation of beltwasher is continuous. A separate on/off switch to be provided to permit operation of conveyor without beltwasher. All piping exposed to view to be chrome plated.

Timed Belt Washing Cycle

(for clean-up operations.)

Beltwasher to be controlled by automatic timer activated by a push button switch inside beltwasher housing in such a manner that the conveyor and beltwasher will operate without interruption for an adjustable cycle of up to 16 minutes. After completion of wash cycle the conveyor is ready for the next start-up.

Detergent Injector

(Select for maximum sanitation. Recirculating beltwasher optional feature is recommended with this option.)

A siphon type detergent injector working in conjunction with the beltwasher water supply is to be furnished.

Removable Work and Storage Shelf

Work and storage shelf to be **Model ACC-2010** made of 16 gauge stainless steel flanged up at rear and both sides. Shelf is supported by stainless steel tubular leg with an adjustable stainless steel bullet foot. Shelf size is 20" x 10". Rear of shelf to be contoured to fit over and slide along the curbing of the conveyor and provided with a positive locking clip to engage the lower edge of the conveyor bed.

Double Overshelf

Double overshelf to be **Model ACC-6015** and to set on the curbing of the conveyor. Two shelves to be 5'-0" long x 15" wide of 16 gauge stainless steel turned down 1" on all four sides, supported by splayed legs of 1" O.D. 16 gauge stainless steel tubing with guides at the bottom to slide to any convenient location.

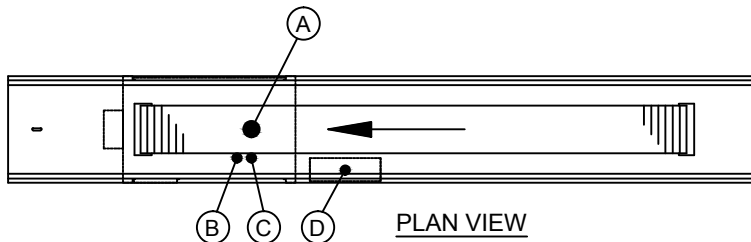

ROUGH-IN SCHEDULE		
NOTE: ALL ROUGH-INS TO BE 4" AFF		
SYM	QTY	DESCRIPTION
A	1	1 1/2" I.P.S. WASTE
B	1	1/2" I.P.S. HOT WATER
C	1	1/2" I.P.S. COLD WATER
D	1	ELECTRICAL CONNECTION

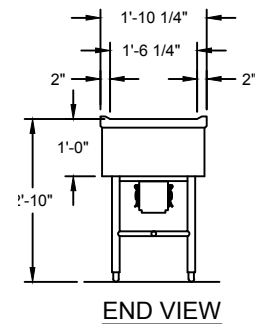
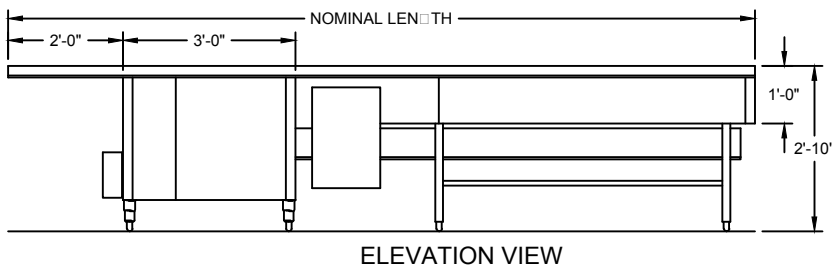

CADDY CORPORATION
 509 Sharptown Road P.O. Box 345
 Bridgeport, NJ 08014-0345
 Tel: 856-467-4222 Fax: 856-467-5511
 internet: www.caddycorp.com

TRAY MAKE-UP CADDY-VEYOR

Choice of Polycarbonate Slatted
or Stretchless PVC Belt



TR-10 belt is low friction polycarbonate slatted belt.

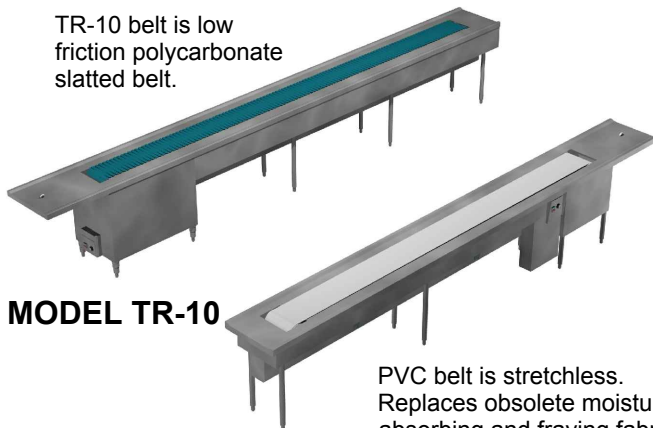

MODEL TR-10

MODEL SM-10

PVC belt is stretchless. Replaces obsolete moisture absorbing and fraying fabric and neoprene belts. PVC belt is FDA approved.

FEATURES

- Ideal as banquet or assembly conveyors for tray up to 17" wide.
E.g.: airlines, school lunchrooms or convention centers.

GENERAL SPECIFICATIONS:

(Select one)

Traymaster TR-10

Tray Make-Up Conveyor shall have variable speed 10" wide self-tracking stainless steel chain. Chain shall have snap on/off low friction polycarbonate slats removable without the use of tools. Slats shall not overlap for ease of cleaning and sanitation.

Servmaster SM-10

Tray Make-Up Conveyor shall have variable speed 10" wide 1/8" thick deep fused moisture-proof double sided PVC belt with adjustable take-up device for tracking.

SPECIFICATIONS:

Unit shall be 20-1/4" wide x 34" high and _____ long, which includes 12" starter section and 24" tray pickup at discharge end.

Top of 14 gauge stainless steel (with raised sides including stainless steel drive housing). Unit shall have 2 removable 18 gauge stainless steel panels and a removable crumb shelf inside housing.

Drive with 1/4 h.p. washdown-type motor, reduction gear, on/off switch, limit switch with tripper arm interwired in a NEMA 4 enclosure. Unit shall be overload protected and U.L. listed stationary or mobile.

Leg assembly of 16 gauge tubular stainless steel 1-5/8" O.D. and 1" O.D. crossbracing completely welded.

(Continue specifications by selecting stationary or mobile model)

Stationary Unit

Fitted with adjustable stainless steel bullet feet.

Mobile Unit

Fitted with 5" diameter polyurethane tired casters, two with brakes. Conveyor shall have 6'-0" long power cord.

Optional Features:

Wireway with Factory Installed Electric Outlets

Provide a recessed stainless steel wireway and electrical outlets with hinged moistureproof covers for adjoining mobile equipment on both sides. Outlets wired to one or more circuit breaker panel(s) as determined by application with each receptacle having its own circuit breaker control with manual reset feature and shutoff. All electrical work to be ready for single final connection by others to each circuit breaker panel at job site.

Specify number of outlets, as well as voltage, phase, wattage or motor size and location for each electrical plug-in outlet required. Preferred input voltage is 120/208v, 3ph, 5 wire system including ground.

IMPORTANT NOTE ON ELECTRICAL DATA

Maximum allowable amperage for mobile tray make-up conveyor is 100 amps 3 phase. If total amperage exceeds 100 amp, 3 phase, a second circuit breaker panel will be required. A separate electrical connection is needed in the field for EACH circuit breaker panel on the conveyor.

Removable Work and Storage Shelf for Advance Make-Up of Soup and Beverages

Work and storage shelf to be **Model ACC-2010** made of 16 gauge stainless steel flanged up at rear and both sides. Shelf supported by stainless steel tubular leg with adjustable stainless steel bullet foot. Shelf size to be 20" 10". Rear of shelf to be contoured to fit over and slide along curbing of conveyor and provided with positive locking clip to engage lower edge of conveyor bed.

Double Overshelf for Storage

Double overshelf to be **Model ACC-6015** and to set on curbing of conveyor. to be approximately 5'-0" long with two shelves 15" wide of 16 gauge stainless steel turned down 1" on all four sides, supported by played legs of 1" O.D. 16 gauge stainless steel tubing with guides at bottom to slide to any convenient location.

Heat Lamp

Hot Food Wells

Cold Food Wells



TRAY MAKE-UP CADDY-VEYOR



Choice of Polycarbonate Slatted
or Stretchless PVC Belt

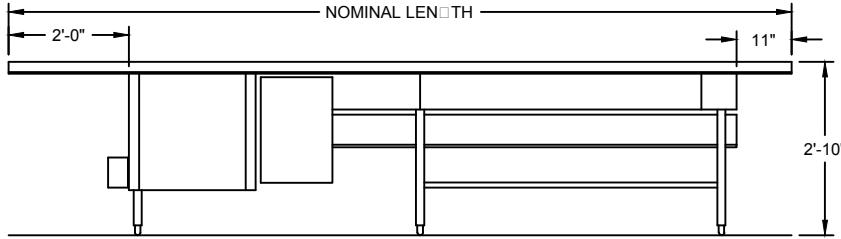

TR-10 ELEVATION VIEW

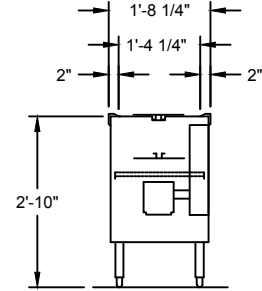

TR-10 SECTION

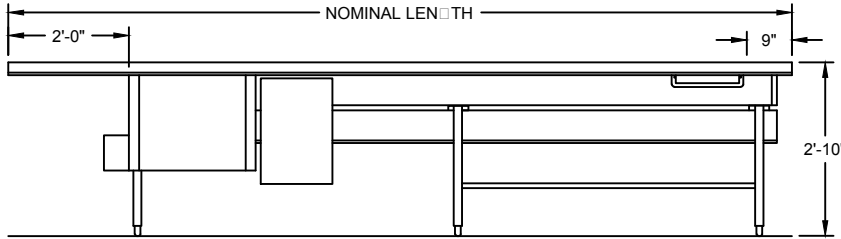

SM-10 ELEVATION VIEW

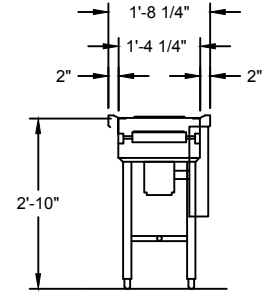

SM-10 SECTION

Stationary Conveyor

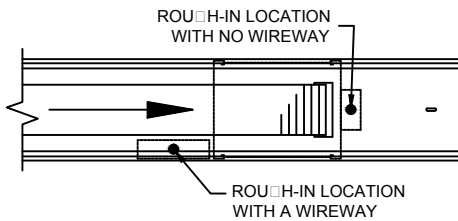

Sketches shown are for general layout purposes only, subject to changes without prior notice consistent with latest design changes. For final dimensional and roughing data, special drawings applicable to a specific order should be requested from Caddy Engineering Department.



CADDY CORPORATION

509 Sharptown Road P.O. Box 345
Bridgeport, NJ 08014-0345
Tel: 856-467-4222 Fax: 856-467-5511
internet: www.caddycorp.com



TRAY MAKE-UP CADDY-VEYOR

Stretchless PVC Belt

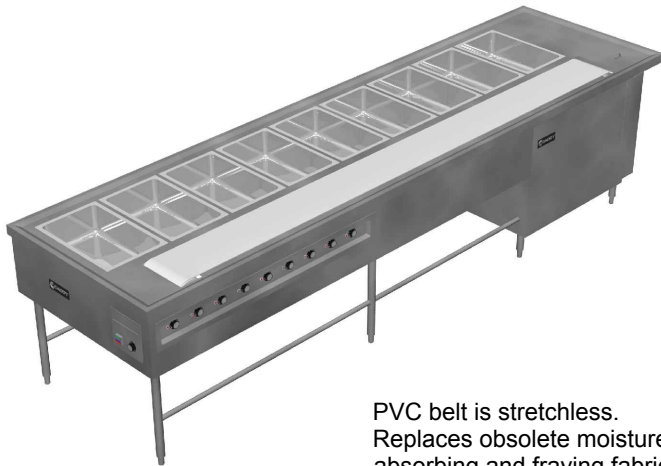

MODEL SM-10-H

PVC belt is stretchless.
Replaces obsolete moisture
absorbing and fraying fabric
and neoprene belts.
PVC belt is FDA approved.

GENERAL SPECIFICATIONS:

Servmaster SM-10-H

Tray Make-Up Conveyor shall have variable speed
10" wide 1/8" thick deep fused moisture-proof
double sided PVC belt with adjustable take-up device
for tracking.

SPECIFICATIONS:

Unit shall be 41" wide x 34" high and _____ long, which
includes 12" starter section and 24" tray pickup at discharge
end.

Top of 14 gauge stainless steel (with raised sides
including stainless steel drive housing). Unit shall have 2
removable 18 gauge stainless steel panels and a removable
crumb shelf inside housing.

Drive with 1/4 h.p. washdown-type motor, reduction
gear, on/off switch, limit switch with tripper arm interwired in
a NEMA 4 enclosure. Unit shall be overload protected and
U.L. listed stationary or mobile.

Leg assembly of 16 gauge tubular stainless steel
1-5/8" O.D. and 1" O.D. crossbracing completely welded.

Hot food wells to measure 12" x 20" x 6-3/8" deep, of
seamless drawn stainless steel with coved corners, fully
insulated and encased in separate metal housing. Each hot
food well to be provided with a heating element of not less
than 1 KW, hi-heat thermostatic limit switch, pilot light and
infinite heat control allowing operator to select and stabilize
any level of holding heat from 0 to maximum input. Infinite
heat control and pilot light for each well to be recessed in
easy-to-observe tilted front panel. Wells to be for moist and
dry heat operation and to accommodate full or partial size
pans up to 6" deep.*

Frame structure to consist of 18 gauge stainless steel
formed pedestals to be reinforced with 16 gauge stainless
steel channels, to have full height extruded plastic vertical
bumpers. Casters are to be 4" diameter heavy duty, double
ball bearing, swivel type with polyurethane tires. Two
casters to be provided with foot brakes. Unit to be
completely wired and provided with a 6'-0" long cord and
plug located on side specified at time of order.

(Continue specifications by selecting stationary or mobile model)

Stationary Unit

Fitted with adjustable stainless steel bullet feet.

Mobile Unit

Fitted with 5" diameter polyurethane tired casters, two with
brakes. Conveyor shall have 6'-0" long power cord.

Optional Features:

Wireway with Factory Installed Electric Outlets

Provide a recessed stainless steel wireway and electrical
outlets with hinged moistureproof covers for adjoining mobile
equipment on both sides. Outlets wired to one or more
circuit breaker panel(s) as determined by application with
each receptacle having its own circuit breaker control with
manual reset feature and shutoff. All electrical work to be
ready for single final connection by others to each circuit
breaker panel at job site.

Specify number of outlets, as well as voltage, phase,
wattage or motor size and location for each electrical plug-in
outlet required. Preferred input voltage is 120/208v, 3ph, 5
wire system including ground.

IMPORTANT NOTE ON ELECTRICAL DATA

Maximum allowable amperage for mobile tray make-up
conveyor is 100 amps 3 phase. If total amperage exceeds
100 amp, 3 phase, a second circuit breaker panel will be
required. A separate electrical connection is needed in the
field for EACH circuit breaker panel on the conveyor.

**Removable Work and Storage Shelf for Advance
Make-Up of Soup and Beverages**

Work and storage shelf to be **Model ACC-2010** made of 16
gauge stainless steel flanged up at rear and both sides.
Shelf supported by stainless steel tubular leg with adjustable
stainless steel bullet foot. Shelf size to be 20" 10". Rear of
shelf to be contoured to fit over and slide along curbing of
conveyor and provided with positive locking clip to engage
lower edge of conveyor bed.

Double Overshelf for Storage

Double overshelf to be **Model ACC-6015** and to set on
curbing of conveyor. to be approximately 5'-0" long with two
shelves 15" wide of 16 gauge stainless steel turned down 1"
on all four sides, supported by splayed legs of 1" O.D. 16
gauge stainless steel tubing with guides at bottom to slide to
any convenient location.

Heat Lamp

Cold Food Wells

Additional 10" Belt



TRAY MAKE-UP CADDY-VEYOR



Choice of Polycarbonate Slatted
or Stretchless PVC Belt

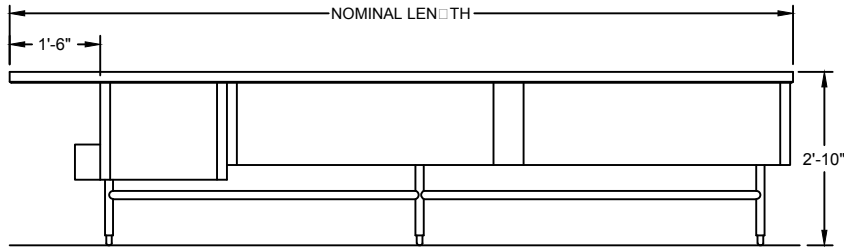

SM-10-H ELEVATION VIEW

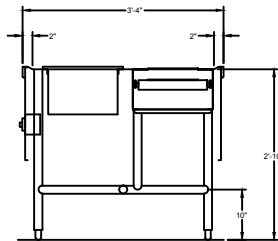

SM-10-H SECTION

Stationary Conveyor

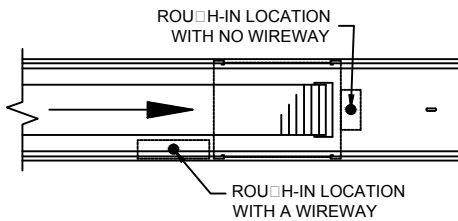

Sketches shown are for general layout purposes only, subject to changes without prior notice consistent with latest design changes. For final dimensional and roughing data, special drawings applicable to a specific order should be requested from Caddy Engineering Department.



CADDY CORPORATION

509 Sharptown Road P.O. Box 345
Bridgeport, NJ 08014-0345
Tel: 856-467-4222 Fax: 856-467-5511
internet: www.caddycorp.com



Stretchless PVC Belt



MODEL SM-H-10-H

PVC belt is stretchless. Replaces obsolete moisture absorbing and fraying fabric and neoprene belts. PVC belt is FDA approved.

GENERAL SPECIFICATIONS:

Servmaster SM-H-10-H

Tray Make-Up Conveyor shall have variable speed 10" wide 1/8" thick deep fused moisture-proof double sided PVC belt with adjustable take-up device for tracking.

SPECIFICATIONS:

Unit shall be 60" wide x 34" high and _____ long, which includes 12" starter section and 24" tray pickup at discharge end.

Top of 14 gauge stainless steel (with raised sides including stainless steel drive housing). Unit shall have 2 removable 18 gauge stainless steel panels and a removable crumb shelf inside housing.

Drive with 1/4 h.p. washdown-type motor, reduction gear, on/off switch, limit switch with tripper arm interwired in a NEMA 4 enclosure. Unit shall be overload protected and U.L. listed stationary or mobile.

Leg assembly of 16 gauge tubular stainless steel 1-5/8" O.D. and 1" O.D. crossbracing completely welded.

Hot food wells to measure 12" x 20" x 6-3/8" deep, of seamless drawn stainless steel with coved corners, fully insulated and encased in separate metal housing. Each hot food well to be provided with a heating element of not less than 1 KW, hi-heat thermostatic limit switch, pilot light and infinite heat control allowing operator to select and stabilize any level of holding heat from 0 to maximum input. Infinite heat control and pilot light for each well to be recessed in easy-to-observe tilted front panel. Wells to be for moist and dry heat operation and to accommodate full or partial size pans up to 6" deep.*

Frame structure to consist of 18 gauge stainless steel formed pedestals to be reinforced with 16 gauge stainless steel channels, to have full height extruded plastic vertical bumpers. Casters are to be 4" diameter heavy duty, double ball bearing, swivel type with polyurethane tires. Two casters to be provided with foot brakes. Unit to be completely wired and provided with a 6'-0" long cord and plug located on side specified at time of order.

(Continue specifications by selecting stationary or mobile model)

Stationary Unit

Fitted with adjustable stainless steel bullet feet.

Mobile Unit

Fitted with 5" diameter polyurethane tired casters, two with brakes. Conveyor shall have 6'-0" long power cord.

Optional Features:

Wireway with Factory Installed Electric Outlets

Provide a recessed stainless steel wireway and electrical outlets with hinged moistureproof covers for adjoining mobile equipment on both sides. Outlets wired to one or more circuit breaker panel(s) as determined by application with each receptacle having its own circuit breaker control with manual reset feature and shutoff. All electrical work to be ready for single final connection by others to each circuit breaker panel at job site.

Specify number of outlets, as well as voltage, phase, wattage or motor size and location for each electrical plug-in outlet required. Preferred input voltage is 120/208v, 3ph, 5 wire system including ground.

IMPORTANT NOTE ON ELECTRICAL DATA

Maximum allowable amperage for mobile tray make-up conveyor is 100 amps 3 phase. If total amperage exceeds 100 amp, 3 phase, a second circuit breaker panel will be required. A separate electrical connection is needed in the field for EACH circuit breaker panel on the conveyor.

Removable Work and Storage Shelf for Advance Make-Up of Soup and Beverages

Work and storage shelf to be **Model ACC-2010** made of 16 gauge stainless steel flanged up at rear and both sides. Shelf supported by stainless steel tubular leg with adjustable stainless steel bullet foot. Shelf size to be 20" 10". Rear of shelf to be contoured to fit over and slide along curbing of conveyor and provided with positive locking clip to engage lower edge of conveyor bed.

Double Overshelf for Storage

Double overshelf to be **Model ACC-6015** and to set on curbing of conveyor. to be approximately 5'-0" long with two shelves 15" wide of 16 gauge stainless steel turned down 1" on all four sides, supported by splayed legs of 1" O.D. 16 gauge stainless steel tubing with guides at bottom to slide to any convenient location.

Heat Lamp

Cold Food Wells

CADDY CORPORATION
 509 Sharptown Road P.O. Box 345
 Bridgeport, NJ 08014-0345
 Tel: 856-467-4222 Fax: 856-467-5511
 internet: www.caddycorp.com

TRAY MAKE-UP CADDY-VEYOR



Choice of Polycarbonate Slatted
or Stretchless PVC Belt

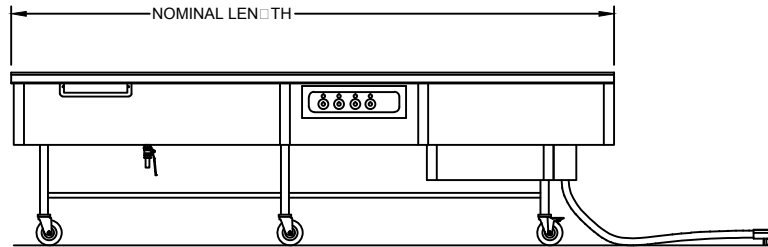

SM-H-10-H ELEVATION VIEW

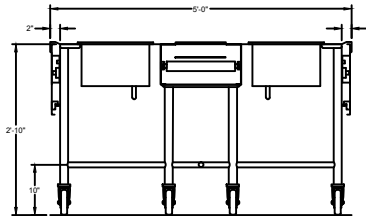

SM-H-10-H SECTION

Stationary Conveyor

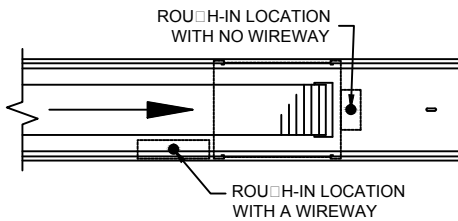

Sketches shown are for general layout purposes only, subject to changes without prior notice consistent with latest design changes. For final dimensional and roughing data, special drawings applicable to a specific order should be requested from Caddy Engineering Department.



CADDY CORPORATION

509 Sharptown Road P.O. Box 345
Bridgeport, NJ 08014-0345
Tel: 856-467-4222 Fax: 856-467-5511
internet: www.caddycorp.com



TRAY MAKE-UP CADDY-VEYOR NON-POWERED / RCF

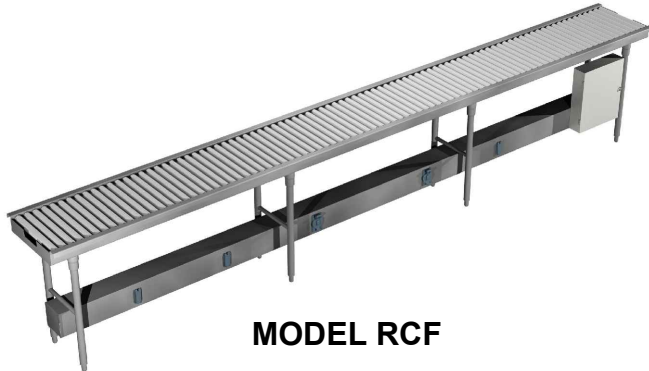

MODEL RCF

FEATURES

- Heavy duty deluxe tray make-up Roller-veyor, will handle any type trays (flat bottom or irregular bottom). Non-mechanized, non-powered.

Specification:

Series RCF Roller tray make-up conveyor to be as manufactured by Caddy Corporation Unit shall be 19-1/4" wide x _____ long, and to accommodate trays up to 16" wide. (Specify dimensions of trays to be used.)

Conveyor bed to have a single row of full width 1-1/4" O.D. plastic rollers with stainless steel balls in nylon bearings, spaced on approximately 3" centers with stainless steel hardware. Conveyor to be provided with 16 gauge stainless steel bed of welded construction, ground and polished. Conveyor to be 34" high to top of rollers. Both longitudinal curbing for conveyor bed to have channeled edges with 1" turndown and extending 1-1/2" above the top of the roller. Structural supports to be stainless steel and welded to underside of conveyor bed. Each end of conveyor bed to be provided with tray stop and hand lift access with bed cleanout provision.

Leg assembly of 16 gauge tubular stainless steel 1-5/8" O.D. and 1" O.D. crossbracing completely welded.

(Continue specifications by selecting stationary or mobile model)

Stationary Unit

Fitted with adjustable stainless steel bullet feet.

Mobile Unit

Fitted with 5" diameter polyurethane tired casters, two with brakes. Conveyor shall have 6'-0" long power cord if conveyor includes optional wireway.

Optional Features:

1-1/4" O.D. Spring Loaded Plastic Rollers

Provide single row of full width 1-1/4" O.D. plastic rollers with stainless steel balls in nylon bearings, spaced at approximately 3" centers with stainless steel spring loaded hexagon snap-in shafts.

Wireway with Factory Installed Electric Outlets

Provide a recessed stainless steel wireway and electrical outlets with hinged moistureproof covers for adjoining mobile equipment on both sides. Outlets wired to one or more circuit breaker panel(s) as determined by application with each receptacle having its own circuit breaker control with manual reset feature and shutoff. All electrical work to be ready for single final connection by others to each circuit breaker panel at job site.

Specify number of outlets, as well as voltage, phase, wattage or motor size and location for each electrical plug-in outlet required. Preferred input voltage is 120/208v, 3ph, 5 wire system including ground.

IMPORTANT NOTE ON ELECTRICAL DATA

Maximum allowable amperage for mobile tray make-up conveyor is 100 amps, 3 phase. If total amperage exceeds 100 amp, 3 phase, a second circuit breaker panel will be required. A separate electrical connection is needed in the field for EACH circuit breaker panel on the conveyor.

Removable Work and Storage Shelf for Advance Make-Up of Soup and Beverages

Work and storage shelf to be **Model ACC-2010** made of 16 gauge stainless steel flanged up at rear and both sides. Shelf supported by stainless steel tubular leg with adjustable stainless steel bullet foot. Shelf size to be 20" □ 10". Rear of shelf to be contoured to fit over and slide along curbing of conveyor and provided with positive locking clip to engage lower edge of conveyor bed.

Double Overshelf for Storage of Cookies, Crackers, Desserts, etc.

Double overshelf to be **Model ACC-6015** and to set on curbing of conveyor. to be approximately 5'-0" long with two shelves 15" wide of 16 gauge stainless steel turned down 1" on all four sides, supported by splayed legs of 1" O.D. 16 gauge stainless steel tubing with guides at bottom to slide to any convenient location.

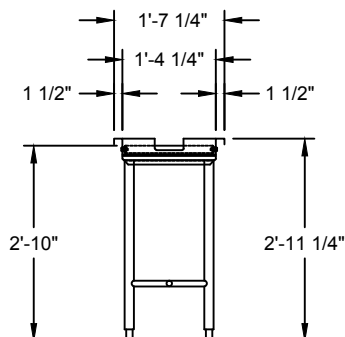

CADDY CORPORATION
509 Sharptown Road P.O. Box 345
Bridgeport, NJ 08014-0345
Tel: 856-467-4222 Fax: 856-467-5511
internet: www.caddycorp.com

TRAY MAKE-UP CADDY-VEYOR NON-POWERED / SWF

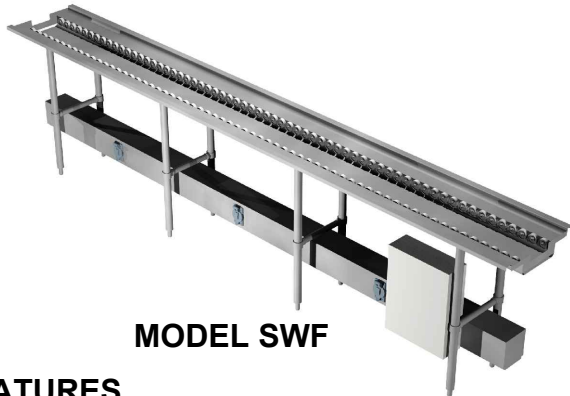

MODEL SWF

FEATURES

- Most economical non-mechanized, non-powered Caddy-veyor. Use only for flat bottom trays. (Not used for trays with irregular bottoms).

Specification:

Series SWF Skatewheel tray make-up conveyor to be as manufactured by Caddy Corporation. Unit shall be 19-1/4" wide x _____ long, and to accommodate flat bottom trays up to 16" wide. (Specify dimensions of trays to be used.)

Conveyor bed to have two rows of 1.9" O.D. plastic skatewheels with stainless steel ball bearings spaced on approximately 2-1/4" centers and mounted with stainless steel hardware. Conveyor to be provided with 16 gauge stainless steel bed of welded construction, ground and polished. Conveyor to be 34" high to top of skatewheels. Both longitudinal curbing for conveyor bed to have channeled edges with 1" turndown and extending 1-1/2" above the top of the skatewheels. Structural supports to be stainless steel and welded to underside of conveyor bed. Each end of conveyor bed to be provided with tray stop and hand lift access with bed cleanout provision.

Leg assembly of 16 gauge tubular stainless steel 1-5/8" O.D. and 1" O.D. crossbracing completely welded.

(Continue specifications by selecting stationary or mobile model)

Stationary Unit

Fitted with adjustable stainless steel bullet feet.

Mobile Unit

Fitted with 5" diameter polyurethane tired casters, two with brakes. Conveyor shall have 6'-0" long power cord if optional wireway is included with the conveyor.

Optional Features:

Wireway with Factory Installed Electrical Outlets

Provide a recessed stainless steel wireway and electrical outlets with hinged moistureproof covers for adjoining mobile equipment on both sides. Outlets wired to one or more circuit breaker panel(s) as determined by application with each receptacle having its own circuit breaker control with manual reset feature and shutoff. All electrical work to be ready for single final connection by others to each circuit breaker panel at job site.

Specify number of outlets, as well as voltage, phase, wattage or motor size and location for each electrical plug-in outlet required. Preferred input voltage is 120/208v, 3ph, 5 wire system including ground.

IMPORTANT NOTE ON ELECTRICAL DATA

Maximum allowable amperage for mobile tray make-up conveyor is 100 amps 3 phase. If total amperage exceeds 100 amp, 3 phase, a second circuit breaker panel will be require. A separate electrical connection is needed in the field for EACH circuit breaker panel on the conveyor.

Removable Work and Storage Shelf for Advance Make-Up of Soup and Beverages

Work and storage shelf to be **Model ACC-2010** made of 16 gauge stainless steel flanged up at rear and both sides. Shelf supported by stainless steel tubular leg with adjustable stainless steel bullet foot. Shelf size to be 20" □ 10". Rear of shelf to be contoured to fit over and slide along curbing of conveyor and provided with positive locking clip to engage lower edge of conveyor bed.

Double Overshelf for Storage of Cookies, Crackers, Desserts, etc.

Double overshelf to be **Model ACC-6015** and to set on curbing of conveyor. To be approximately 5'-0" long with two shelves 15" wide of 16 gauge stainless steel turned down 1" on all four sides, supported by splayed legs of 1" O.D. 16 gauge stainless steel tubing with guides at bottom to slide to any convenient location.

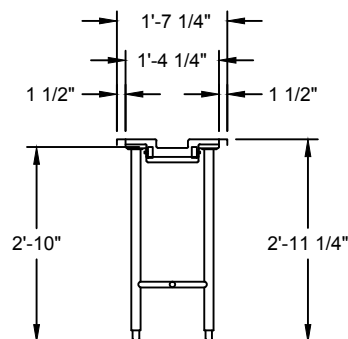

PRECISION SKATEWHEELS
WITH STAINLESS STEEL
BALL BEARINGS ON 2 1/4"
CENTERS

CADDY CORPORATION
509 Sharptown Road P.O. Box 345
Bridgeport, NJ 08014-0345
Tel: 856-467-4222 Fax: 856-467-5511
internet: www.caddycorp.com

TRAY MAKE-UP CADDY-VEYOR



CANTILEVERED MOBILE CONVEYOR (RCC/SWC)
TABLE OR HOT FOOD MOUNT CONVEYOR (SKW)



MODEL SWC



MODEL RCC

FEATURES

- Provides maximum flexibility in the positioning of Roller or Skatewheel conveyor during serving time in conjunction with hot food Caddy. Conveyor can be rolled away and stored when not in use.

Specification:

Cantilevered support structure of all welded stainless steel construction with all welds ground smooth and polished. Base to be formed of two 12 gauge stainless steel channels fitted with four heavy duty 4" swivel casters, two with brakes. Uprights to be 1-5/8" O.D. stainless steel tubing. Support braces of 12 gauge stainless steel welded to stainless steel sleeves allowing vertical adjustment of conveyor bed from 14-1/2" to 20-1/2" above top deck of hot food Caddy.

Conveyor (covered under separate specifications section) to be bolted to the two cantilever brackets resulting in unitized mobile assembly. Entire assembly to be:

(Select one)

Model SWC

Tray make-up conveyor to be as manufactured by Caddy Corporation. Unit shall be 19 1/4" wide x _____ long, and to accommodate flat bottom trays up to 16" wide. (Specify dimensions of trays to be used.)

Model RCC

Tray make-up conveyor to be as manufactured by Caddy Corporation. Unit shall be 19 1/4" wide x _____ long, and to accommodate trays up to 16" wide. (Specify dimensions of trays to be used.)

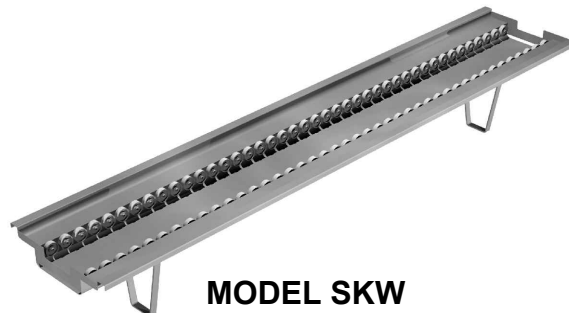
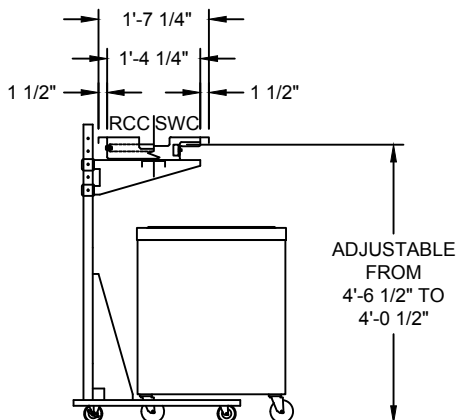

MODEL SKW

FEATURES

- Skatewheel conveyor can turn any table or hot food unit into an efficient system for assembling trays for up to 150 beds.
- Most economical non-mechanized, non-powered Caddy-veyor. Use only for flat bottom trays. (Not used for trays with irregular bottoms).

Specification:

Series SKW Skatewheel tray make-up conveyor to be as manufactured by Caddy Corporation. Unit shall be 19-1/4" wide x _____ long, and to accommodate flat bottom trays up to 16" wide. (Specify dimensions of trays to be used.)

Conveyor bed to have two rows of 1.9" O.D. plastic skatewheels with stainless steel ball bearings spaced on approximately 2-1/4" centers and mounted with stainless steel hardware. Conveyor to be provided with 16 gauge stainless steel bed of welded construction, ground and polished. Conveyor to be 10-1/2" above hot food unit or table. Both longitudinal curbing for conveyor bed to have channeled edges with 1" turndown and extending 1-1/2" above the top of the skatewheels. Structural supports to be 1" x 1/4" stainless steel flat bar with mounting holes and welded to underside of conveyor bed. Each end of conveyor bed to be provided with tray stop and hand lift access with bed cleanout provision.

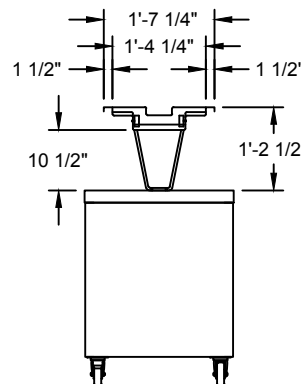

CADDY CORPORATION
509 Sharptown Road P.O. Box 345
Bridgeport, NJ 08014-0345
Tel: 856-467-4222 Fax: 856-467-5511
internet: www.caddycorp.com



CADDY CORPORATION

Food Service Equipment

Air Systems

Self Leveling Dispensers

Self-Leveling Dispensers

Drop-In Style for

Plates, Bowls, Saucers, Cups & Glasses



PROJECT:

LOCATION:



CM-10
CM-10-S
CM-10-H



CM-20
CM-20-S
CM-20-H



CM-30
CM-30-S
CM-30-H



CM-40
CM-40-S
CM-40-H



CM-50
CM-50-S
CM-50-H

CM-50-TS
CM-50-TS-S
CM-50-TS-H

Model (Open) ****	Dish/Bowl Dia.	Countertop Cutout Dia.	Flange Outside Dia.
CM-10	up to 5 $\frac{3}{4}$ "	8 $\frac{3}{8}$ "	9 $\frac{5}{8}$ "
CM-20	5 $\frac{7}{8}$ " to 7 $\frac{1}{4}$ "	9 $\frac{7}{8}$ "	11 $\frac{1}{8}$ "
CM-30	7 $\frac{3}{8}$ " to 9 $\frac{1}{2}$ "	11 $\frac{3}{4}$ "	13 $\frac{1}{8}$ "
CM-40	9 $\frac{5}{8}$ " to 10 $\frac{1}{8}$ "	12 $\frac{3}{4}$ "	14"
CM-50	10 $\frac{1}{4}$ " to 12"	14 $\frac{1}{2}$ "	15 $\frac{3}{4}$ "
CM-50-TS	12"	14 $\frac{1}{2}$ "	15 $\frac{3}{4}$ "

Model (Shielded) (Unheated)	Dish/Bowl Dia.	Countertop Cutout Dia.	Flange Outside Dia.
CM-10-S	up to 5 $\frac{3}{4}$ "	8 $\frac{3}{8}$ "	9 $\frac{5}{8}$ "
CM-20-S	5 $\frac{7}{8}$ " to 7 $\frac{1}{4}$ "	9 $\frac{7}{8}$ "	11 $\frac{1}{8}$ "
CM-30-S	7 $\frac{3}{8}$ " to 9 $\frac{1}{2}$ "	11 $\frac{3}{4}$ "	13 $\frac{1}{8}$ "
CM-40-S	9 $\frac{5}{8}$ " to 10 $\frac{1}{8}$ "	12 $\frac{3}{4}$ "	14"
CM-50-S	10 $\frac{1}{4}$ " to 12"	14 $\frac{1}{2}$ "	15 $\frac{3}{4}$ "
CM-50-S-TS	12"	14 $\frac{1}{2}$ "	15 $\frac{3}{4}$ "

Capacity: up to 72 plates or 36 bowls (72 cups or 40 glasses with ACC-24) ***

Model (Shielded) (Heated)	Dish/Bowl Dia.	Countertop Cutout Dia.	Flange Outside Dia.	Electrical Data				NEMA	
				Volts	Phase	Amps	Watts	Plug	Outlet **
CM-10-H	up to 5 $\frac{3}{4}$ "	8 $\frac{3}{8}$ "	9 $\frac{5}{8}$ "	120	1	2.9	350	5-15P	5-15R
CM-20-H	5 $\frac{7}{8}$ " to 7 $\frac{1}{4}$ "	9 $\frac{7}{8}$ "	11 $\frac{1}{8}$ "	120	1	4.2	500	5-15P	5-15R
CM-30-H	7 $\frac{3}{8}$ " to 9 $\frac{1}{2}$ "	11 $\frac{3}{4}$ "	13 $\frac{1}{8}$ "	120	1	4.2	500	5-15P	5-15R
CM-40-H	9 $\frac{5}{8}$ " to 10 $\frac{1}{8}$ "	12 $\frac{3}{4}$ "	14"	120	1	4.2	500	5-15P	5-15R
CM-50-H	10 $\frac{1}{4}$ " to 12"	14 $\frac{1}{2}$ "	15 $\frac{3}{4}$ "	120	1	8.8	650	5-15P	5-15R
CM-50-H-TS	12"	14 $\frac{1}{2}$ "	15 $\frac{3}{4}$ "	120	1	8.8	650	5-15P	5-15R

*** Actual capacities vary with shape of object to be dispensed.

** Outlet not supplied by Caddy Corporation.

**** For application in heated compartments, cabinets, or counters, Open types must be specified

General Specifications

Caddy Magic self-leveling drop-in dispenser to be Caddy Corporation model CM-_____.

Self-leveling cylinders to be field adjustable without the use of tools for china and plastic dishes without requiring prior identification, irrespective of weight, height, or brand.

Calibrating mechanism to have multiple extension springs peripherally suspended from a circular storage bank.

Selective engaging of springs with dish carrier assembly to permit balancing and dispensing of any load within range of model selected.

Dispenser housing to consist of an 18 gauge stainless steel die-stamped reinforced base, three equally spaced vertical stainless steel guides with raised beads to minimize friction, and 18 gauge stainless steel raised top flange, in high luster finish, with three 3" high plastic guide posts equally spaced, all unitized into one welded rigid cylindrical assembly.

Unit to be 27-1/2" in height*. Internal dish carrier assembly to consist of die-stamped 20 gauge stainless steel removable top platform supported by a wire cage made of 3/16" diameter stainless steel securely stabilized for its vertical travels. Stack height of dishware to midpoint of guide post to be not less than 22". Shielded models to have 22 gauge stainless steel cylindrical enclosure.

Electrical components to consist of top mounted on/off switch, pilot light and knob adjustable thermostat. Thermostat to be bi-metallic, adjustable cycling type, to maintain selected level of temperature with minimum fluctuations. Heating elements to be tubular, stainless steel, sheathed, hi-intensity loop type. A rubber-jacketed cord with three-prong male plug to be furnished. Entire dispenser to be wired for 120 volt A.C. single phase operation.

Heated units only to be approved by Intertek.



Unit to be provided with the following accessories:

Accessories

- ACC-24** - Set of nine stainless steel cup and glass trays. (Supplied standard for models CM-50-TS, CM-50-S-TS, & CM-50H-TS)

CADDY CORPORATION
 509 Sharptown Road P.O. Box 345
 Bridgeport, NJ 08014-0345
 Tel: 856-467-4222 Fax: 856-467-5511
 internet: www.caddycorp.com

* Height excludes guide posts. Add 3" for overall height.

Self-Leveling Dispensers for Plates, Bowls, & Saucers (Heated)

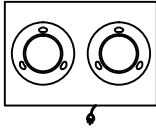
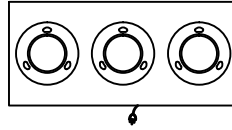
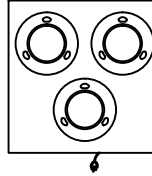
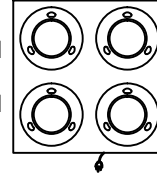
 CM-S-102-H
to
CM-S-502-H

 CM-S-103-H
to
CM-S-503-H

 CM-SQ-103-H
to
CM-SQ-503-H

 CM-S-104-H
to
CM-S-504-H

Two Dispenser Capacity up to 144 plates or 72 bowls **

Model	Dish/Bowl Dia.	Length	Width	Height
CM-S-102-H	up to 5 $\frac{3}{4}$ "	23 $\frac{1}{2}$ "	16"	34" *
CM-S-202-H	5 $\frac{7}{8}$ " to 7 $\frac{1}{4}$ "	23 $\frac{1}{2}$ "	16"	34" *
CM-S-302-H	7 $\frac{3}{8}$ " to 9 $\frac{1}{2}$ "	29 $\frac{1}{4}$ "	16"	34" *
CM-S-402-H	9 $\frac{5}{8}$ " to 10 $\frac{1}{8}$ "	29 $\frac{1}{4}$ "	16"	34" *
CM-S-502-H	10 $\frac{1}{4}$ " to 12"	33"	16 $\frac{1}{2}$ "	34" *

Three Dispenser Capacity up to 216 plates or 108 bowls **

Model	Dish/Bowl Dia.	Length	Width	Height
CM-SQ-103-H	up to 5 $\frac{3}{4}$ "	23 $\frac{1}{2}$ "	23 $\frac{1}{2}$ "	34" *
CM-SQ-203-H	5 $\frac{7}{8}$ " to 7 $\frac{1}{4}$ "	23 $\frac{1}{2}$ "	23 $\frac{1}{2}$ "	34" *
CM-SQ-303-H	7 $\frac{3}{8}$ " to 9 $\frac{1}{2}$ "	29 $\frac{1}{4}$ "	29 $\frac{1}{4}$ "	34" *
CM-SQ-403-H	9 $\frac{5}{8}$ " to 10 $\frac{1}{8}$ "	29 $\frac{1}{4}$ "	29 $\frac{1}{4}$ "	34" *
CM-SQ-503-H	10 $\frac{1}{4}$ " to 12"	33"	33"	34" *

Three Dispenser Capacity up to 216 plates or 108 bowls **

Model	Dish/Bowl Dia.	Length	Width	Height
CM-S-103-H	up to 5 $\frac{3}{4}$ "	35 $\frac{1}{4}$ "	16"	34" *
CM-S-203-H	5 $\frac{7}{8}$ " to 7 $\frac{1}{4}$ "	35 $\frac{1}{4}$ "	16"	34" *
CM-S-303-H	7 $\frac{3}{8}$ " to 9 $\frac{1}{2}$ "	43 $\frac{7}{8}$ "	16"	34" *
CM-S-403-H	9 $\frac{5}{8}$ " to 10 $\frac{1}{8}$ "	43 $\frac{7}{8}$ "	16"	34" *
CM-S-503-H	10 $\frac{1}{4}$ " to 12"	49 $\frac{1}{2}$ "	16 $\frac{1}{2}$ "	34" *

Four Dispenser Capacity up to 288 plates or 144 bowls **

Model	Dish/Bowl Dia.	Length	Width	Height
CM-S-104-H	up to 5 $\frac{3}{4}$ "	23 $\frac{1}{2}$ "	23 $\frac{1}{2}$ "	34" *
CM-S-204-H	5 $\frac{7}{8}$ " to 7 $\frac{1}{4}$ "	23 $\frac{1}{2}$ "	23 $\frac{1}{2}$ "	34" *
CM-S-304-H	7 $\frac{3}{8}$ " to 9 $\frac{1}{2}$ "	29 $\frac{1}{4}$ "	29 $\frac{1}{4}$ "	34" *
CM-S-404-H	9 $\frac{5}{8}$ " to 10 $\frac{1}{8}$ "	29 $\frac{1}{4}$ "	29 $\frac{1}{4}$ "	34" *
CM-S-504-H	10 $\frac{1}{4}$ " to 12"	33"	33"	34" *

* Height excludes flange & guide posts. Add 3-1/4" for overall height.
** Actual capacities vary with shape of object to be dispensed.

General Specifications

Caddy Magic self-leveling dispenser to be Caddy Corporation model CM-_____.

Unit to have 16 gauge stainless steel top with 2" turned down channel edge on 4 sides and welded finished corners. Exterior of cabinet to be finished in stainless steel.

Self-leveling cylinders to be field adjustable without the use of tools for china dishes without requiring prior identification, irrespective of weight, height, or brand. Calibrating mechanism to have multiple extension springs peripherally suspended from a circular storage bank. Selective engaging of springs with dish carrier assembly to permit balancing and dispensing of any load within range of model selected. Cylinders to have 18 gauge stainless steel raised top flange, in high luster finish, with three 3" high plastic guide posts equally spaced.

Bottom of cabinet to be 12 gauge stainless steel, rust resistant metal and body to have full height vertical plastic corner bumpers. Casters are to be 4" diameter swivel type with polyurethane tires. Casters on diagonal corners to be provided with foot brakes.

Electrical control box to be stainless steel and installed for easy removal for service. Control box to be furnished with on/off switch, pilot light with infinite Hi-Lo heat control for temperature settings 1 through 9, and a recessed male three-pronged NEMA twist-lock receptacle. Unit to be supplied with a 6'-0" long cord with a NEMA twist-lock female connector at one end and a three prong male plug at the other end. Heating elements of stainless steel, hi-intensity.

Unit to be provided with the following accessories:

Accessories

- ACC-63 - 5" diameter swivel casters with polyurethane tires in lieu of 4" diameter swivel casters. (Add 1-1/8" to height)
- ACC-50 - Perimeter bumpers with replaceable corner bumpers. (Add 1-1/4" to length and width)
- ACC-52 - Vertical corner bumpers only. Easy to replace. (Add 1-1/4" to length and width)
- ACC-97 - Aluminum dome covers



CADDY CORPORATION

509 Sharptown Road P.O. Box 345
Bridgeport, NJ 08014-0345
Tel: 856-467-4222 Fax: 856-467-5511
internet: www.caddycorp.com

China plates heat to 150° in approximately 2 hours.

**Self-Leveling Dispensers for
Plates, Bowls, & Saucers (Heated)**



TOP VIEW

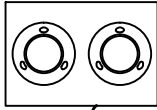

CM-S-102-H
to
CM-S-502-H



Model	Electrical Data				NEMA	
	Volts	Phase	Amps	Watts	Plug	Outlet *
CM-S-102-H	120	1	7.9	950	5-15P	5-15R
CM-S-202-H						
CM-S-302-H						
CM-S-402-H	208	1	4.6	950	6-15P	6-15R
CM-S-502-H						
CM-S-502-H	240	1	4.0	950	6-15P	6-15R

* Outlet not supplied by Caddy Corporation.

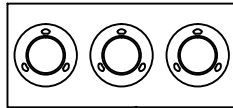

CM-S-103-H
to
CM-S-503-H



Model	Electrical Data				NEMA	
	Volts	Phase	Amps	Watts	Plug	Outlet *
CM-S-103-H	120	1	7.9	950	5-15P	5-15R
CM-S-203-H						
CM-S-303-H						
CM-S-403-H	208	1	4.6	950	6-15P	6-15R
CM-S-503-H						
CM-S-503-H	240	1	4.0	950	6-15P	6-15R

* Outlet not supplied by Caddy Corporation.

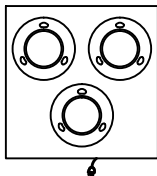

CM-SQ-103-H
to
CM-SQ-503-H

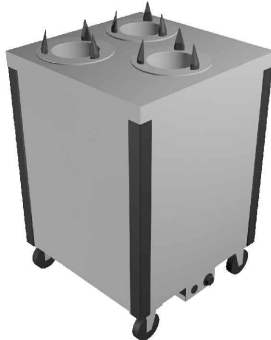

Model	Electrical Data				NEMA	
	Volts	Phase	Amps	Watts	Plug	Outlet *
CM-SQ-103-H	120	1	7.9	950	5-15P	5-15R
CM-SQ-203-H						
CM-SQ-303-H						
CM-SQ-403-H	208	1	4.6	950	6-15P	6-15R
CM-SQ-503-H						
CM-SQ-503-H	240	1	4.0	950	6-15P	6-15R

* Outlet not supplied by Caddy Corporation.

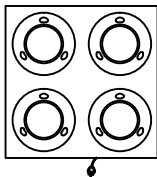

CM-S-104-H
to
CM-S-504-H

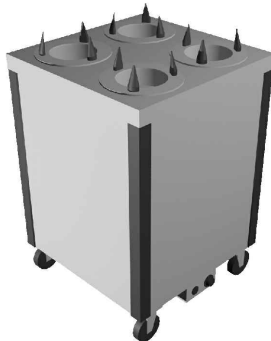

Model	Electrical Data				NEMA	
	Volts	Phase	Amps	Watts	Plug	Outlet *
CM-S-104-H	120	1	10.0	1240	5-15P	5-15R
CM-S-204-H						
CM-S-304-H						
CM-S-404-H	208	1	6.0	1240	6-15P	6-15R
CM-S-504-H						
CM-S-504-H	240	1	4.2	1240	6-15P	6-15R

* Outlet not supplied by Caddy Corporation.



CADDY CORPORATION

509 Sharptown Road P.O. Box 345
Bridgeport, NJ 08014-0345
Tel: 856-467-4222 Fax: 856-467-5511
internet: www.caddycorp.com

Self-Leveling Dispensers for Plates, Bowls, & Saucers (Unheated)

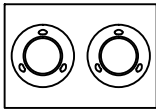
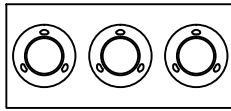
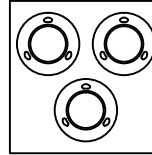
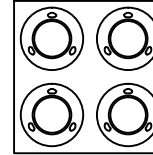
 CM-S-102
to
CM-S-502

 CM-S-103
to
CM-S-503

 CM-SQ-103
to
CM-SQ-503

 CM-S-104
to
CM-S-504

Two Dispenser Capacity up to 144 plates or 72 bowls **

Model	Dish/Bowl Dia.	Length	Width	Height
CM-S-102	up to 5 $\frac{3}{4}$ "	23 $\frac{1}{2}$ "	16"	34" *
CM-S-202	5 $\frac{7}{8}$ " to 7 $\frac{1}{4}$ "	23 $\frac{1}{2}$ "	16"	34" *
CM-S-302	7 $\frac{3}{8}$ " to 9 $\frac{1}{2}$ "	29 $\frac{1}{4}$ "	16"	34" *
CM-S-402	9 $\frac{5}{8}$ " to 10 $\frac{1}{8}$ "	29 $\frac{1}{4}$ "	16"	34" *
CM-S-502	10 $\frac{1}{4}$ " to 12"	33"	16 $\frac{1}{2}$ "	34" *

Three Dispenser Capacity up to 216 plates or 108 bowls **

Model	Dish/Bowl Dia.	Length	Width	Height
CM-SQ-103	up to 5 $\frac{3}{4}$ "	23 $\frac{1}{2}$ "	23 $\frac{1}{2}$ "	34" *
CM-SQ-203	5 $\frac{7}{8}$ " to 7 $\frac{1}{4}$ "	23 $\frac{1}{2}$ "	23 $\frac{1}{2}$ "	34" *
CM-SQ-303	7 $\frac{3}{8}$ " to 9 $\frac{1}{2}$ "	29 $\frac{1}{4}$ "	29 $\frac{1}{4}$ "	34" *
CM-SQ-403	9 $\frac{5}{8}$ " to 10 $\frac{1}{8}$ "	29 $\frac{1}{4}$ "	29 $\frac{1}{4}$ "	34" *
CM-SQ-503	10 $\frac{1}{4}$ " to 12"	33"	33"	34" *

Three Dispenser Capacity up to 216 plates or 108 bowls **

Model	Dish/Bowl Dia.	Length	Width	Height
CM-S-103	up to 5 $\frac{3}{4}$ "	35 $\frac{1}{4}$ "	16"	34" *
CM-S-203	5 $\frac{7}{8}$ " to 7 $\frac{1}{4}$ "	35 $\frac{1}{4}$ "	16"	34" *
CM-S-303	7 $\frac{3}{8}$ " to 9 $\frac{1}{2}$ "	43 $\frac{7}{8}$ "	16"	34" *
CM-S-403	9 $\frac{5}{8}$ " to 10 $\frac{1}{8}$ "	43 $\frac{7}{8}$ "	16"	34" *
CM-S-503	10 $\frac{1}{4}$ " to 12"	49 $\frac{1}{2}$ "	16 $\frac{1}{2}$ "	34" *

Four Dispenser Capacity up to 288 plates or 144 bowls **

Model	Dish/Bowl Dia.	Length	Width	Height
CM-S-104	up to 5 $\frac{3}{4}$ "	23 $\frac{1}{2}$ "	23 $\frac{1}{2}$ "	34" *
CM-S-204	5 $\frac{7}{8}$ " to 7 $\frac{1}{4}$ "	23 $\frac{1}{2}$ "	23 $\frac{1}{2}$ "	34" *
CM-S-304	7 $\frac{3}{8}$ " to 9 $\frac{1}{2}$ "	29 $\frac{1}{4}$ "	29 $\frac{1}{4}$ "	34" *
CM-S-404	9 $\frac{5}{8}$ " to 10 $\frac{1}{8}$ "	29 $\frac{1}{4}$ "	29 $\frac{1}{4}$ "	34" *
CM-S-504	10 $\frac{1}{4}$ " to 12"	33"	33"	34" *

* Height excludes flange & guide posts. Add 3-1/4" for overall height.

** Actual capacities vary with shape of object to be dispensed.

General Specifications

Caddy Magic self-leveling dispenser to be Caddy Corporation model CM-_____.

Unit to have 16 gauge stainless steel top with 2" turned down channel edge on 4 sides and welded finished corners. Exterior of cabinet to be finished in stainless steel.

Self-leveling cylinders to be field adjustable without the use of tools for china and plastic dishes without requiring prior identification, irrespective of weight, height, or brand. Calibrating mechanism to have multiple extension springs peripherally suspended from a circular storage bank. Selective engaging of springs with dish carrier assembly to permit balancing and dispensing of any load within range of model selected. Cylinders to have 18 gauge stainless steel raised top flange, in high luster finish, with three 3" high plastic guide posts equally spaced.

Bottom of cabinet to be 12 gauge stainless steel, rust resistant metal and body to have full height vertical plastic corner bumpers. Casters are to be 4" diameter swivel type with polyurethane tires.

Unit to be provided with the following accessories:

Accessories

- ACC-63** - 5" diameter swivel casters with polyurethane tires in lieu of 4" diameter swivel casters. (Add 1-1/8" to height)
- ACC-41** - Caster brakes on two diagonal casters.
- ACC-50** - Perimeter bumpers with replaceable corner bumpers. (Add 1-1/4" to length and width)
- ACC-52** - Vertical corner bumpers only. Easy to replace. (Add 1-1/4" to length and width)

CADDY CORPORATION
 509 Sharptown Road P.O. Box 345
 Bridgeport, NJ 08014-0345
 Tel: 856-467-4222 Fax: 856-467-5511
 internet: www.caddycorp.com

Self-Leveling Dispensers for

Cups, Saucers, Glasses, & Bowls Heated and Unheated



PROJECT:

LOCATION:

CM-1020
CM-1020-D*
CM-1020-H

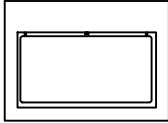

CM-2620-10
CM-2620-D-10*
CM-2620-H-10

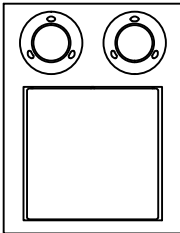

Capacities* and Dimensions**

Model	Cups	Glasses	Bowls	Saucers	Length	Width	Height
CM-1020 CM-1020-D CM-1020-H	70	95	----	----	25 $\frac{3}{8}$ "	18 $\frac{1}{2}$ "	34 $\frac{1}{4}$ "
CM-2020 CM-2020-D CM-2020-H	140	190	96	----	25 $\frac{3}{8}$ "	27 $\frac{1}{2}$ "	34 $\frac{1}{4}$ "
CM-2620-10 CM-2620-D-10 CM-2620-H-10	140	----	----	140 (up to 5 $\frac{3}{4}$ " dia)	27 $\frac{1}{2}$ "	35 $\frac{1}{2}$ "	34 $\frac{1}{4}$ "**
CM-2620-20 CM-2620-D-20 CM-2620-H-20	140	----	----	140 (5 $\frac{7}{8}$ " to 7 $\frac{1}{4}$ " dia)	27 $\frac{1}{2}$ "	35 $\frac{1}{2}$ "	34 $\frac{1}{4}$ "**

** Height excludes flange & guide posts. Add 3 $\frac{1}{4}$ " for overall height.
*** Actual capacities vary with shape of object to be dispensed.

CM-2020
CM-2020-D*
CM-2020-H

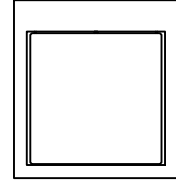

CM-2620-20
CM-2620-D-20*
CM-2620-H-20

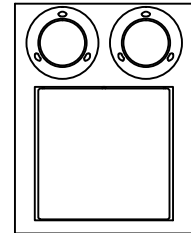

* Denotes door model

General Specifications

Caddy Magic self-leveling dispenser to be Caddy Corporation model CM-_____.

Unit to have 16 gauge stainless steel top with 2" turned down channel edge on 4 sides and welded finished corners. Exterior of cabinet to be stainless steel. Cabinet corners to be reinforced with 16 gauge stainless steel channels and to have full height extruded plastic vertical bumpers.

Bottom of cabinet to be 12 gauge stainless steel, rust resistant metal and to have 2-1/2" diameter center clean-out hole with a removable plug. Unit to be mounted on four 4" diameter swivel type casters with polyurethane tires.

Self-leveling mechanism to be cantilevered suspension type. Removable panel to be provided to permit easy calibration without the use of tools, for full load factors from 20 to 182 pounds and without prior identification of wares, irrespective of weight, height, or brand. Mechanism to be free of cables, chains, pulleys, sprockets, gears, levers, crank handles or components that may require periodic maintenance and lubrication.

Removable load platform to be 18 gauge stainless steel and secured to 16 gauge stainless steel angle support frame and a pair of cantilevered suspension arms. Suspension arms to be of rust-resistant 1/4" steel and to be securely guided by ball bearing rollers. Total stacking height to edge of top frame to be not less than 22".

Door model specifications:

Unit to have hinged pan-type stainless steel door to facilitate storage of empty racks. Door to match cabinet exterior and provided with vertical finger grip and self-latching mechanism.

Saucer model specifications:

Self-leveling cylinders to be field adjustable without the use of tools for china and plastic dishes without requiring prior identification, irrespective of weight, height, or brand. Calibrating mechanism to have multiple extension springs peripherally suspended from a circular storage bank. Selective engaging of springs with dish carrier assembly to permit balancing and dispensing of any load within range of model selected. Cylinders to have 18 gauge stainless steel raised top flange, in high luster finish, with three 3" high plastic guide posts equally spaced.

Unit to be provided with the following accessories:

Accessories

- ACC-63** - 5" diameter swivel casters with polyurethane tires in lieu of 4" diameter swivel casters. (Add 1-1/8" to height)
- ACC-41** - Caster brakes on two diagonal casters. (standard on heated units)
- ACC-50** - Perimeter bumpers with replaceable corner bumpers. (Add 1-1/4" to length and width)
- ACC-52** - Vertical corner bumpers only. Easy to replace. (Add 1-1/4" to length and width)

Continue to page 2 of 2 for heated unit specifications.

CADDY CORPORATION
509 Sharptown Road P.O. Box 345
Bridgeport, NJ 08014-0345
Tel: 856-467-4222 Fax: 856-467-5511
internet: www.caddycorp.com

Self-Leveling Dispensers for

**Cups, Saucers, Glasses, & Bowls
Heated and Unheated**



TOP VIEW



CM-1020-H



Electrical Data				NEMA	
Model	Volts	Phase	Amps	Plug	Outlet *
CM-1020-H	120	1	7.9	5-15P	5-15R
	208	1	4.6	6-15P	6-15R
	240	1	4.0	6-15P	6-15R

* Outlet not supplied by Caddy Corporation.

TOP VIEW

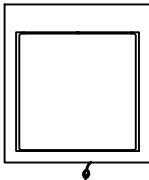

CM-2020-H



Electrical Data				NEMA	
Model	Volts	Phase	Amps	Plug	Outlet *
CM-2020-H	120	1	10.3	5-15P	5-15R
	208	1	6.0	6-15P	6-15R
	240	1	5.2	6-15P	6-15R

* Outlet not supplied by Caddy Corporation.

TOP VIEW

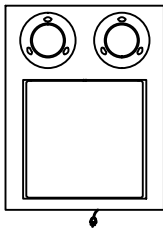

CM-2620-H-10
(SHOWN)



Electrical Data				NEMA	
Model	Volts	Phase	Amps	Plug	Outlet *
CM-2620-H-10 CM-2620-H-20	120	1	10.3	5-15P	5-15R
	208	1	6.0	6-15P	6-15R
	240	1	5.2	6-15P	6-15R

* Outlet not supplied by Caddy Corporation.

Heated model specifications:

Two diagonal casters to have foot brakes.

Electrical control box to be stainless steel and installed for easy removal for servicing. (Control box to be furnished with on/off switch with integral pilot light, with infinite Hi-Lo heat control for temperature settings 1 through 9, and a recessed male three-pronged NEMA twist-lock receptacle.) Elements to be stainless steel, tubular and of hi-intensity. Unit to be supplied with a 6'-0" long cord with a NEMA twist-lock female connector at one end and a three prong male plug at the other end. Heating elements of stainless steel, hi-intensity.

Heated units only to be certified by Intertek.



CADDY CORPORATION
 509 Sharptown Road P.O. Box 345
 Bridgeport, NJ 08014-0345
 Tel: 856-467-4222 Fax: 856-467-5511
 internet: www.caddycorp.com

Self-Leveling Dispensers Open Tubular Style for Plates, Bowls, & Saucers (Unheated)

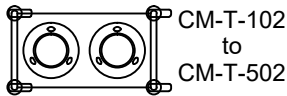
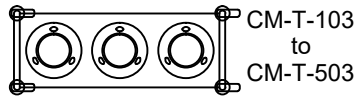
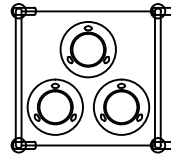
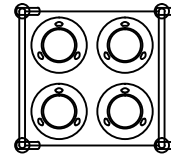
 CM-T-102
to
CM-T-502

 CM-T-103
to
CM-T-503

 CM-TQ-103
to
CM-TQ-503

 CM-T-104
to
CM-T-504

Two Dispenser Capacity up to 144 plates or 72 bowls **

Model	Dish/Bowl Dia.	Length	Width	Height
CM-T-102	up to 5 $\frac{3}{4}$ "	26 $\frac{3}{4}$ "	15 $\frac{3}{8}$ "	37"
CM-T-202	5 $\frac{7}{8}$ " to 7 $\frac{1}{4}$ "	26 $\frac{3}{4}$ "	15 $\frac{3}{8}$ "	37"
CM-T-302	7 $\frac{3}{8}$ " to 9 $\frac{1}{2}$ "	32 $\frac{1}{2}$ "	17 $\frac{1}{8}$ "	37"
CM-T-402	9 $\frac{5}{8}$ " to 10 $\frac{1}{8}$ "	32 $\frac{1}{2}$ "	17 $\frac{1}{8}$ "	37"
CM-T-502	10 $\frac{1}{4}$ " to 12"	36 $\frac{1}{4}$ "	19"	37"

Three Dispenser Capacity up to 216 plates or 108 bowls **

Model	Dish/Bowl Dia.	Length	Width	Height
CM-TQ-103	up to 5 $\frac{3}{4}$ "	26 $\frac{3}{4}$ "	25 $\frac{3}{4}$ "	37"
CM-TQ-203	5 $\frac{7}{8}$ " to 7 $\frac{1}{4}$ "	26 $\frac{3}{4}$ "	25 $\frac{3}{4}$ "	37"
CM-TQ-303	7 $\frac{3}{8}$ " to 9 $\frac{1}{2}$ "	32 $\frac{1}{2}$ "	31 $\frac{1}{2}$ "	37"
CM-TQ-403	9 $\frac{5}{8}$ " to 10 $\frac{1}{8}$ "	32 $\frac{1}{2}$ "	31 $\frac{1}{2}$ "	37"
CM-TQ-503	10 $\frac{1}{4}$ " to 12"	36 $\frac{1}{4}$ "	35 $\frac{1}{4}$ "	37"

Three Dispenser Capacity up to 216 plates or 108 bowls **

Model	Dish/Bowl Dia.	Length	Width	Height
CM-T-103	up to 5 $\frac{3}{4}$ "	38 $\frac{1}{4}$ "	15 $\frac{3}{8}$ "	37"
CM-T-203	5 $\frac{7}{8}$ " to 7 $\frac{1}{4}$ "	38 $\frac{1}{4}$ "	15 $\frac{3}{8}$ "	37"
CM-T-303	7 $\frac{3}{8}$ " to 9 $\frac{1}{2}$ "	46 $\frac{7}{8}$ "	17 $\frac{1}{8}$ "	37"
CM-T-403	9 $\frac{5}{8}$ " to 10 $\frac{1}{8}$ "	46 $\frac{7}{8}$ "	17 $\frac{1}{8}$ "	37"
CM-T-503	10 $\frac{1}{4}$ " to 12"	52 $\frac{1}{2}$ "	19"	37"

Four Dispenser Capacity up to 288 plates or 144 bowls **

Model	Dish/Bowl Dia.	Length	Width	Height
CM-T-104	up to 5 $\frac{3}{4}$ "	26 $\frac{3}{4}$ "	25 $\frac{3}{4}$ "	37"
CM-T-204	5 $\frac{7}{8}$ " to 7 $\frac{1}{4}$ "	26 $\frac{3}{4}$ "	25 $\frac{3}{4}$ "	37"
CM-T-304	7 $\frac{3}{8}$ " to 9 $\frac{1}{2}$ "	32 $\frac{1}{2}$ "	31 $\frac{1}{2}$ "	37"
CM-T-404	9 $\frac{5}{8}$ " to 10 $\frac{1}{8}$ "	32 $\frac{1}{2}$ "	31 $\frac{1}{2}$ "	37"
CM-T-504	10 $\frac{1}{4}$ " to 12"	36 $\frac{1}{4}$ "	35 $\frac{1}{4}$ "	37"

** Actual capacities vary with shape of object to be dispensed.

General Specifications

Caddy Magic self-leveling dispenser to be Caddy Corporation model CM-_____.

Unit to have 16 gauge stainless steel reinforced top and 1" O.D. 16 gauge stainless steel tubular frame of all welded construction with stainless steel cross bracing on four sides. Casters to be 4" diameter heavy-duty swivel type with 3/4" stems and polyurethane tires.

Self-leveling cylinders to be field adjustable without the use of tools for china and plastic dishes, without requiring prior identification, irrespective of weight, height, or brand. Calibrating mechanism to have multiple extension springs peripherally suspended from a circular storage bank. Selective engaging of springs with dish carrier assembly to permit balancing and dispensing of any load within range of model selected. Each cylinder to have a 20 gauge stainless steel enclosure and 18 gauge stainless steel raised top flange, in high luster finish, with three 3" high plastic guide posts equally spaced.

Unit to be provided with the following accessories:

Accessories

- ACC-63** - 5" diameter swivel casters with polyurethane tires in lieu of 4" diameter swivel casters. (Add 1-1/8" to height)
- ACC-41** - Caster brakes on two diagonal casters.
- ACC-38** - Circular bumpers. (Add 4" to length and width)

CADDY CORPORATION
 509 Sharptown Road P.O. Box 345
 Bridgeport, NJ 08014-0345
 Tel: 856-467-4222 Fax: 856-467-5511
 internet: www.caddycorp.com

Self-Leveling Dispensers Open Tubular Style for Plates, Bowls, & Saucers (Heated)

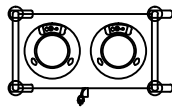
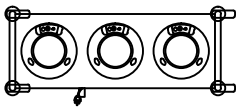
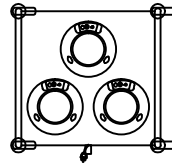
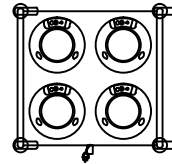
 CM-T-102-H
to
CM-T-502-H

 CM-T-103-H
to
CM-T-503-H

 CM-TQ-103-H
to
CM-TQ-503-H

 CM-T-104-H
to
CM-T-504-H

Two Dispenser Capacity up to 144 plates or 72 bowls **

Model	Dish/Bowl Dia.	Length	Width	Height
CM-T-102-H	up to 5 $\frac{3}{4}$ "	26 $\frac{3}{4}$ "	15 $\frac{3}{8}$ "	37"
CM-T-202-H	5 $\frac{7}{8}$ " to 7 $\frac{1}{4}$ "	26 $\frac{3}{4}$ "	15 $\frac{3}{8}$ "	37"
CM-T-302-H	7 $\frac{3}{8}$ " to 9 $\frac{1}{2}$ "	32 $\frac{1}{2}$ "	17 $\frac{1}{8}$ "	37"
CM-T-402-H	9 $\frac{5}{8}$ " to 10 $\frac{1}{8}$ "	32 $\frac{1}{2}$ "	17 $\frac{1}{8}$ "	37"
CM-T-502-H	10 $\frac{1}{4}$ " to 12"	36 $\frac{1}{4}$ "	19"	37"

Three Dispenser Capacity up to 216 plates or 108 bowls **

Model	Dish/Bowl Dia.	Length	Width	Height
CM-TQ-103-H	up to 5 $\frac{3}{4}$ "	26 $\frac{3}{4}$ "	25 $\frac{3}{4}$ "	37"
CM-TQ-203-H	5 $\frac{7}{8}$ " to 7 $\frac{1}{4}$ "	26 $\frac{3}{4}$ "	25 $\frac{3}{4}$ "	37"
CM-TQ-303-H	7 $\frac{3}{8}$ " to 9 $\frac{1}{2}$ "	32 $\frac{1}{2}$ "	31 $\frac{1}{2}$ "	37"
CM-TQ-403-H	9 $\frac{5}{8}$ " to 10 $\frac{1}{8}$ "	32 $\frac{1}{2}$ "	31 $\frac{1}{2}$ "	37"
CM-TQ-503-H	10 $\frac{1}{4}$ " to 12"	36 $\frac{1}{4}$ "	35 $\frac{1}{4}$ "	37"

Three Dispenser Capacity up to 216 plates or 108 bowls **

Model	Dish/Bowl Dia.	Length	Width	Height
CM-T-103-H	up to 5 $\frac{3}{4}$ "	38 $\frac{1}{4}$ "	15 $\frac{3}{8}$ "	37"
CM-T-203-H	5 $\frac{7}{8}$ " to 7 $\frac{1}{4}$ "	38 $\frac{1}{4}$ "	15 $\frac{3}{8}$ "	37"
CM-T-303-H	7 $\frac{3}{8}$ " to 9 $\frac{1}{2}$ "	46 $\frac{7}{8}$ "	17 $\frac{1}{8}$ "	37"
CM-T-403-H	9 $\frac{5}{8}$ " to 10 $\frac{1}{8}$ "	46 $\frac{7}{8}$ "	17 $\frac{1}{8}$ "	37"
CM-T-503-H	10 $\frac{1}{4}$ " to 12"	52 $\frac{1}{2}$ "	19"	37"

Four Dispenser Capacity up to 288 plates or 144 bowls **

Model	Dish/Bowl Dia.	Length	Width	Height
CM-T-104-H	up to 5 $\frac{3}{4}$ "	26 $\frac{3}{4}$ "	25 $\frac{3}{4}$ "	37"
CM-T-204-H	5 $\frac{7}{8}$ " to 7 $\frac{1}{4}$ "	26 $\frac{3}{4}$ "	25 $\frac{3}{4}$ "	37"
CM-T-304-H	7 $\frac{3}{8}$ " to 9 $\frac{1}{2}$ "	32 $\frac{1}{2}$ "	31 $\frac{1}{2}$ "	37"
CM-T-404-H	9 $\frac{5}{8}$ " to 10 $\frac{1}{8}$ "	32 $\frac{1}{2}$ "	31 $\frac{1}{2}$ "	37"
CM-T-504-H	10 $\frac{1}{4}$ " to 12"	36 $\frac{1}{4}$ "	35 $\frac{1}{4}$ "	37"

** Actual capacities vary with shape of object to be dispensed.

General Specifications

Caddymagic self-leveling dispenser to be Caddy Corporation model CM-_____.

Unit to have 16 gauge stainless steel reinforced top and 1" O.D. 16 gauge stainless steel tubular frame of all welded construction with stainless steel cross bracing on four sides. Casters to be 4" diameter heavy-duty swivel type with 3/4" stems and polyurethane tires. Casters on diagonal corners to be provided with foot brakes.

Self-leveling cylinders to be field adjustable without the use of tools for china and plastic dishes without requiring prior identification, irrespective of weight, height, or brand. Calibrating mechanism to have multiple extension springs peripherally suspended from a circular storage bank. Selective engaging of springs with dish carrier assembly to permit balancing and dispensing of any load within range of model selected. Each cylinder to have a 20 gauge stainless steel enclosure and 18 gauge stainless steel raised top flange, in high luster finish, with three 3" high plastic guide posts equally spaced.

Electrical components to consist of top mounted on/off switch, pilot light and knob adjustable thermostat. Thermostat to be bi-metallic, adjustable, cycling type to maintain selected level of temperature with minimum fluctuations. Heating elements to be tubular, stainless steel sheathed, hi-intensity, loop type. A junction box with recessed receptacles for plugging in each dispenser to be provided and fitted with rubber-jacketed drop cord and three prong male plug with stainless steel hook. Unit to be wired for 120 volts, A.C., single phase.

Unit to be provided with the following accessories:

Accessories

- ACC-63 - 5" diameter swivel casters with polyurethane tires in lieu of 4" diameter swivel casters. (Add 1-1/8" to height)
- ACC-38 - Circular bumpers. (Add 4" to length and width)
- ACC-97 - Aluminum dome covers

CADDY CORPORATION
 509 Sharptown Road P.O. Box 345
 Bridgeport, NJ 08014-0345
 Tel: 856-467-4222 Fax: 856-467-5511
 internet: www.caddycorp.com

Self-Leveling Dispensers Open Tubular Style for Plates, Bowls, & Saucers (Heated)



PROJECT:

LOCATION:

TOP VIEW

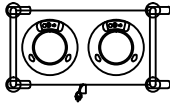

CM-T-102-H
to
CM-T-502-H



Model	Electrical Data				NEMA	
	Volts	Phase	Amps	Watts	Plug	Outlet *
CM-T-102-H	120	1	5.8	700	5-15P	5-15R
CM-T-202-H CM-T-302-H CM-T-402-H	120	1	8.3	1000	5-15P	5-15R
CM-T-502-H	120	1	10.8	1300	5-15P	5-15R

* Outlet not supplied by Caddy Corporation.

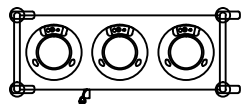

CM-T-103-H
to
CM-T-503-H



Model	Electrical Data				NEMA	
	Volts	Phase	Amps	Watts	Plug	Outlet *
CM-T-103-H	120	1	8.8	1050	5-15P	5-15R
CM-T-203-H CM-T-303-H CM-T-403-H	120	1	12.5	1500	5-15P	5-15R
CM-T-503-H	120	1	16.3	1950	5-20P	5-20R

* Outlet not supplied by Caddy Corporation.

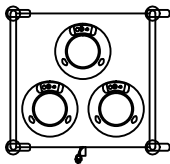

CM-TQ-103-H
to
CM-TQ-503-H



Model	Electrical Data				NEMA	
	Volts	Phase	Amps	Watts	Plug	Outlet *
CM-TQ-103-H	120	1	8.8	1050	5-15P	5-15R
CM-TQ-203-H CM-TQ-303-H CM-TQ-403-H	120	1	12.5	1500	5-15P	5-15R
CM-TQ-503-H	120	1	16.3	1950	5-20P	5-20R

* Outlet not supplied by Caddy Corporation.

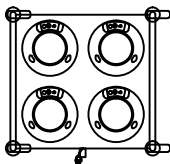

CM-T-104-H
to
CM-T-504-H



Model	Electrical Data				NEMA	
	Volts	Phase	Amps	Watts	Plug	Outlet *
CM-T-104-H	120	1	11.6	1400	5-15P	5-15R
CM-T-204-H CM-T-304-H CM-T-404-H	120	1	16.6	2000	5-20P	5-20R
CM-T-504-H	120	1	21.6	2600	5-30P	5-30R

* Outlet not supplied by Caddy Corporation.



CADDY CORPORATION

509 Sharptown Road P.O. Box 345
Bridgeport, NJ 08014-0345
Tel: 856-467-4222 Fax: 856-467-5511
internet: www.caddycorp.com

Self-Leveling Dispensers "The Super Heater" for 9" China Plates



Dispenses super heated (165°F - 175°F) dishes in 2 hours to keep food temperatures at desired serving levels. Highly efficient with pelletized or plate-underliners systems.
Not recommended for plastic dishes

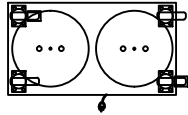

CM-S-302-SH

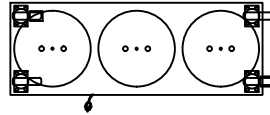

CM-S-303-SH

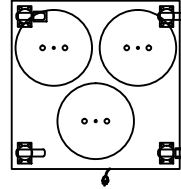

CM-SQ-303-SH

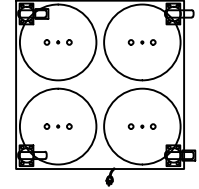

CM-S-304-SH

Dietitians and patients demand that hot foods be served hot at bedside. The primary protection against loss of food heat is the plate itself. Caddy has developed this super heating self-leveling plate dispenser. It is safe with all china.

It is no longer necessary to accept inferior dispensers that deliver plates at 125°F - 150°F. Now you can rely on the *Super Heater*.

Super heated plates hold higher food temperatures efficiently with either pelletized or space age plate underliners

Dimensions

Model	Plate Dia. (qty)	Length	Width	Height
CM-S-302-SH	Up to 9 1/2" (144*)	29 1/4"	16"	35 1/4" **
CM-S-303-SH	Up to 9 1/2" (216*)	44"	16"	35 1/4" **
CM-SQ-303-SH	Up to 9 1/2" (216*)	29 1/4"	29 1/4"	35 1/4" **
CM-S-304-SH	Up to 9 1/2" (288*)	29 1/4"	29 1/4"	35 1/4" **

* Actual capacities vary with shape of object to be dispensed.
** Height excludes dome covers. Add 4-3/4" to overall height for dome covers.

General Specifications

Caddy Magic Super Heat self-leveling dispenser to be Caddy Corporation model CM-_____.

Unit to have 16 gauge stainless steel top with 2" turned down channel edge on 4 sides and welded finished corners. Exterior of cabinet to be finished in stainless steel.

Self-leveling cylinders to be field adjustable without the use of tools for china without requiring prior identification, irrespective of weight, height, or brand. Calibrating mechanism to have multiple extension springs peripherally suspended from a circular storage bank. Selective engaging of springs with dish carrier assembly to permit balancing and dispensing of any load within range of model selected. Cylinders to have 18 gauge stainless steel, raised top flange, in high luster finish.

Each dispenser to be enclosed in full height 1" thick insulation and to have an aluminum dome cover with two finger holes. Dispenser flange to be isolated from cabinet top by a thermal breaker, preventing metal contact between dispenser and cabinet.

Bottom of cabinet to be 12 gauge stainless steel, rust resistant metal. Body to have full height vertical plastic corner bumpers. Casters are to be 5" diameter swivel type with polyurethane tires. Two casters on diagonal corners to be provided with foot brakes.

Unit to have timer wired to hi-intensity sheathed heating elements of a minimum 620 watts. Electrical control box to be stainless steel and installed for easy removal for service. Control box to be furnished with a timer to be adjustable to reach maximum temperature within 2 hours and a recessed male three-pronged NEMA twist-lock receptacle. Unit to be supplied with a 6'-0" long cord with a NEMA twist-lock female connector at one end and a three prong male plug at the other end.

Unit to be provided with the following accessories:

Accessories

- ACC-50** - Perimeter bumpers with replaceable corner bumpers. (Add 1-1/4" to length and width)
- ACC-52** - Vertical corner bumpers only. Easy to replace. (Add 1-1/4" to length and width)
- ACC-54***** - China Plate Lifter will not mar china.

*** Each unit equipped with one ACC-54. Mark only if extra are required.

CADDY CORPORATION
509 Sharptown Road P.O. Box 345
Bridgeport, NJ 08014-0345
Tel: 856-467-4222 Fax: 856-467-5511
internet: www.caddycorp.com

Self-Leveling Dispensers "The Super Heater" for 9" China Plates



TOP VIEW

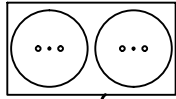

CM-S-302-SH

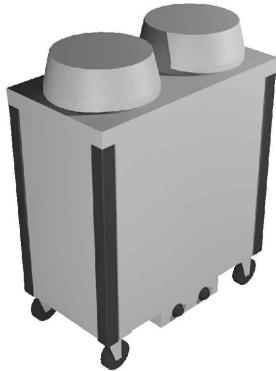

Electrical Data					NEMA	
Model	Volts	Phase	Amps	Watts	Plug	Outlet *
CM-S-302-SH	120	1	10.3	1240	5-15P	5-15R
	208	1	6.0	1240	6-15P	6-15R
	240	1	5.2	1240	6-15P	6-15R

* Outlet not supplied by Caddy Corporation.

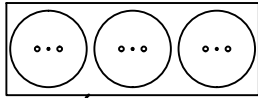

CM-S-303-SH



Electrical Data					NEMA	
Model	Volts	Phase	Amps	Watts	Plug	Outlet *
CM-S-303-SH	120	1	15.5	1860	5-20P	5-20R
	208	1	8.9	1860	6-15P	6-15R

* Outlet not supplied by Caddy Corporation.

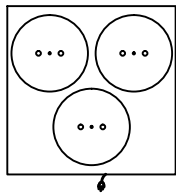

CM-SQ-303-SH

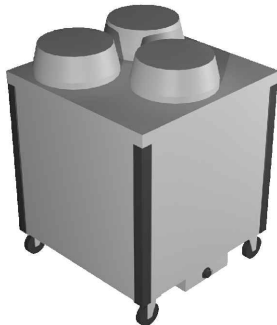

Electrical Data					NEMA	
Model	Volts	Phase	Amps	Watts	Plug	Outlet *
CM-SQ-303-SH	120	1	15.5	1860	5-20P	5-20R
	208	1	8.9	1860	6-15P	6-15R

* Outlet not supplied by Caddy Corporation.

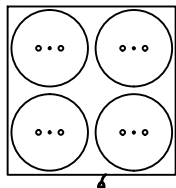

CM-S-304-SH



Electrical Data					NEMA	
Model	Volts	Phase	Amps	Watts	Plug	Outlet *
CM-S-304-SH	120	1	20.7	2480	5-30P	5-30R
	208	1	11.9	2480	6-15P	6-15R
	240	1	10.3	2480	6-15P	6-15R

* Outlet not supplied by Caddy Corporation.

CADDY CORPORATION

 509 Sharptown Road P.O. Box 345
 Bridgeport, NJ 08014-0345
 Tel: 856-467-4222 Fax: 856-467-5511
 internet: www.caddycorp.com

Self-Leveling Dispensers

"Hi-Heat"

for Stainless Steel Underliners & Bases



PROJECT:

LOCATION:

Will heat to 200°F in 90 minutes and 225°F in 2 hours. Highly efficient with Therma-Lock hospital tray service model TL-95 and all other makes

Specify the make of underliner or base to be used.

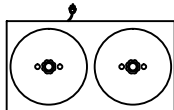

CM-S-302-HH
CM-S-402-HH

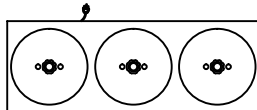

CM-S-303-HH
CM-S-403-HH

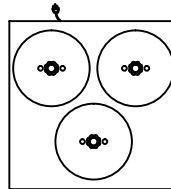

CM-SQ-303-HH

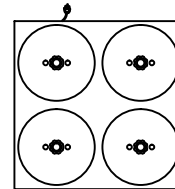

CM-S-304-HH

Dimensions				
Model	Base Dia. (qty)	Length	Width	Height
CM-S-302-HH	Up to 9 1/4" (72*)	29 1/4"	16"	35 1/4" **
CM-S-303-HH	Up to 9 1/4" (108*)	44"	16"	35 1/4" **
CM-SQ-303-HH	Up to 9 1/4" (108*)	29 1/4"	29 1/4"	35 1/4" **
CM-S-304-HH	Up to 9 1/4" (144*)	29 1/4"	29 1/4"	35 1/4" **
CM-S-402-HH	9 1/2" to 10 1/8" (72*)	29 1/4"	16"	35 1/4" **
CM-S-403-HH	9 1/2" to 10 1/8" (108*)	44"	16"	35 1/4" **

* Actual capacities vary with shape of object to be dispensed.

** Height excludes dome covers. Add 5-1/2" to overall height for dome covers.

* * * * *

Caddy base heaters are designed to heat Caddy TL-95 underliners. Underliners manufactured by others should be sent to factory to be tested for proper operation.

* * * * *

General Specifications

Caddy Magic Hi-Heat self-leveling dispenser to be Caddy Corporation model CM-_____.

Unit to have 16 gauge stainless steel top with 2" turned down channel edges on 4 sides and welded finished corners. Exterior of cabinet to be finished in stainless steel.

Self-leveling cylinders to be field adjustable without the use of tools for stainless steel underliners and bases without requiring prior identification, irrespective of weight, height, or brand. Calibrating mechanism to have multiple extension springs peripherally suspended from a circular storage bank. Selective engaging of springs with carrier assembly to permit balancing and dispensing of any load within range of model selected. Cylinders to have 18 gauge stainless steel raised top flange, in high luster finish.

Each dispenser to be enclosed in full height 1" thick insulation and to have an aluminum dome cover with knob. Dispenser flange to be isolated from cabinet top by a thermal breaker, preventing metal contact between dispenser and cabinet.

Bottom of cabinet to be 12 gauge stainless steel, rust resistant metal. Body to have full height vertical plastic corner bumpers. Casters are to be 5" diameter swivel type with polyurethane tires. Two casters on diagonal corners to be provided with foot brakes.

Each cylinder to have individual Hi-Limit thermostat and timer wired to hi-intensity sheathed heating elements of a minimum of 950 watts. Electrical control box to be stainless steel and installed for easy removal for service. Control box to be furnished with a timer to be adjustable to reach maximum temperature within 120 minutes and a recessed male three-pronged NEMA twist-lock receptacle. Unit to be supplied with a 6'-0" long cord with a NEMA twist-lock female connector at one end and a three prong male plug at the other end.

Unit to be provided with the following accessories:

Accessories

- ACC-50 - Perimeter bumpers with replaceable corner bumpers. (Add 1-1/4" to length and width)
- ACC-52 - Vertical corner bumpers only. Easy to replace. (Add 1-1/4" to length and width)
- ACC-53 - Vacuum Lifter for underliners.

CADDY CORPORATION
 509 Sharptown Road P.O. Box 345
 Bridgeport, NJ 08014-0345
 Tel: 856-467-4222 Fax: 856-467-5511
 internet: www.caddycorp.com

CADDY Food Service Systems

ITEM NO:

page 2 of 2

Self-Leveling Dispensers "Hi-Heat"

PROJECT:



for Stainless Steel Underliners & Bases



LOCATION:

TOP VIEW

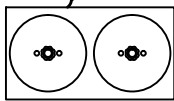

CM-S-302-HH
CM-S-402-HH



Model	Electrical Data				NEMA	
	Volts	Phase	Amps	Watts	Plug	Outlet *
CM-S-302-HH CM-S-402-HH	120	1	15.8	1900	5-20P	5-20R
	208	1	9.1	1900	6-20P	6-20R
	240	1	7.9	1900	6-20P	6-20R

* Outlet not supplied by Caddy Corporation.

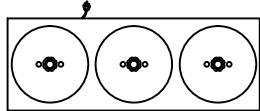

CM-S-303-HH
CM-S-403-HH



Model	Electrical Data				NEMA	
	Volts	Phase	Amps	Watts	Plug	Outlet *
CM-S-303-HH CM-S-403-HH	120	1	23.8	2850	5-30P	5-30R
	208	1	13.7	2850	6-20P	6-20R
	240	1	11.8	2850	6-20P	6-20R
	208	3	9.1	2850	15-20P	15-20R
	240	3	7.9	2850	15-20P	15-20R

* Outlet not supplied by Caddy Corporation.

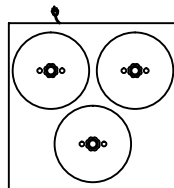

HCM-SQ-303-HH

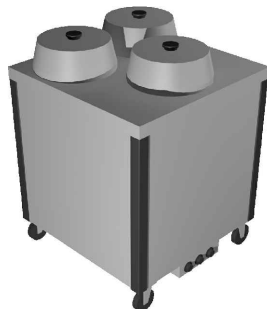

Model	Electrical Data				NEMA	
	Volts	Phase	Amps	Watts	Plug	Outlet *
CM-SQ-303-HH	120	1	23.8	2850	5-30P	5-30R
	208	1	13.7	2850	6-20P	6-20R
	240	1	11.8	2850	6-20P	6-20R
	208	3	9.1	2850	15-20P	15-20R
	240	3	7.9	2850	15-20P	15-20R

* Outlet not supplied by Caddy Corporation.

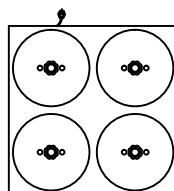

CM-S-304-HH

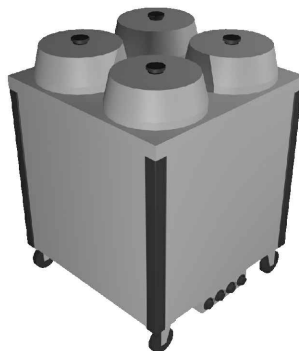

Model	Electrical Data				NEMA	
	Volts	Phase	Amps	Watts	Plug	Outlet *
CM-S-304-HH	208	1	17.3	3800	6-30P	6-30R

* Outlet not supplied by Caddy Corporation.



CADDY CORPORATION

509 Sharptown Road P.O. Box 345
Bridgeport, NJ 08014-0345
Tel: 856-467-4222 Fax: 856-467-5511
internet: www.caddycorp.com

Self-Leveling Dispensers

Combo-Heater

Super Heat Plates & Hi-Heat Pellets



PROJECT:

LOCATION:

TOP VIEW

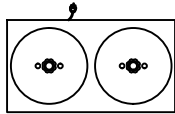

CM-S-302-SHC
1 PELLET HEATER
1 PLATE HEATER

TOP VIEW

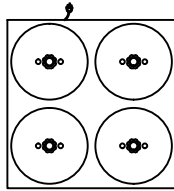

CM-S-304-SHC
2 PELLET HEATER
2 PLATE HEATER

Dimensions

Model	Base Dia. (qty)	Length	Width	Height
CM-S-302-SHC	Up to 9 1/4" (72*)	29 1/4"	16"	35 1/4" ***
CM-S-304-SHC	Up to 9 1/4" (108*)	29 1/4"	29 1/4"	35 1/4" ***

Electrical Data

Model	Electrical Data				NEMA	
	Volts	Phase	Amps	Watts	Plug	Outlet *
CM-S-302-SHC	120	1	13.1	620 950	5-20P	5-20R
	208	1	7.5	620 950	6-20P	6-15R
CM-S-304-SHC	208	1	15.1	1240 1900	6-20P	6-20R
	240	1	13.1	1240 1900	6-20P	6-20R

* Outlet not supplied by Caddy Corporation.

** Actual capacities vary with shape of object to be dispensed.

*** Height excludes dome covers. Add 5-1/2" to overall height for dome covers.

General Specifications

Caddy Magic Combo Heater self-leveling dispenser to be Caddy Corporation model CM-_____.

Unit to have 16 gauge stainless steel top with 2" turned down channel edge on 4 sides and welded finished corners. Exterior of cabinet to be finished in stainless steel.

Self-leveling cylinders to be field adjustable without the use of tools for china dishes and pellet underliners without requiring prior identification, irrespective of weight, height, or brand. Calibrating mechanism to have multiple extension springs peripherally suspended from a circular storage bank. Selective engaging of springs with dish carrier assembly to permit balancing and dispensing of any load within range of model selected. Cylinders to have 18 gauge stainless steel raised top flange, in high luster finish.

Each dispenser to be enclosed in full height 1" thick insulation and to have an aluminum dome cover with knob. Dispenser flange to be isolated from cabinet top by a thermal breaker, preventing metal contact between dispenser and cabinet.

Bottom of cabinet to be 12 gauge stainless steel, rust resistant metal and body to have full height vertical plastic corner bumpers. Casters are to be 5" diameter swivel type with polyurethane tires. Casters on diagonal corners to be provided with foot brakes.

Unit to include (1) ACC-54 China Plate Lifter.

Each pellet cylinder to have individual clickstat and timer wired to hi-intensity sheathed heating elements of a minimum of 950 watts. Each plate cylinder to have individual clickstat and timer wired to hi-intensity sheathed heating elements of a minimum 620 watts. Electrical control box to be stainless steel and installed for easy removal for service. Control box to be furnished with a timer to be adjustable to reach maximum temperature within 2 hours and a recessed male three-pronged NEMA twist-lock receptacle. Unit to be supplied with a 6'-0" long cord with a NEMA twist-lock female connector at one end and a three prong male plug at the other end.

Unit to be provided with the following accessories:

Accessories

- ACC-50 - Perimeter bumpers with replaceable corner bumpers. (Add 1-1/4" to length and width)
- ACC-52 - Vertical corner bumpers only. Easy to replace. (Add 1-1/4" to length and width)
- ACC-53 - Vacuum Lifter for pellet underliners.
- ACC-54 - China Plate Lifter will not mar china.

CADDY CORPORATION
509 Sharptown Road P.O. Box 345
Bridgeport, NJ 08014-0345
Tel: 856-467-4222 Fax: 856-467-5511
internet: www.caddycorp.com

Self-Leveling Dispensers for Oval Platters (Heated and Unheated) Cabinet and Drop-In



CM-S-132

Cabinet Style

CM-S-133

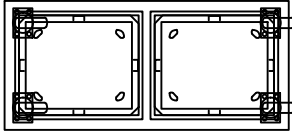
Drop-In Style

CM-S-132-H

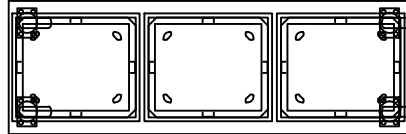

CM-S-133-H

CM-D-1013

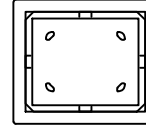

CM-D-1013	
Countertop Cutout	Flange Outside
15 $\frac{3}{4}$ " X 13"	1 $\frac{1}{2}$ "

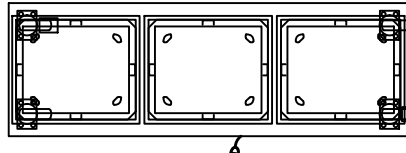
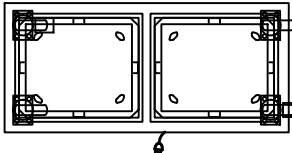

Units dispense oval platters up to 10 $\frac{1}{2}$ " wide x 13" long			
Model	Length	Width	Height
CM-S-132	35 $\frac{1}{4}$ "	16"	34" **
CM-S-132-H	35 $\frac{1}{4}$ "	16"	34" **
CM-S-133	49 $\frac{1}{2}$ "	16 $\frac{1}{2}$ "	34" **
CM-S-133-H	29 $\frac{1}{4}$ "	29 $\frac{1}{4}$ "	34" **
CM-D-1013	17 $\frac{3}{4}$ "	15 $\frac{1}{2}$ "	28" **

Electrical Data				NEMA	
Model	Volts	Phase	Amps	Plug	Outlet *
CM-S-132-H CM-S-133-H	120	1	7.9	5-15P	5-15R
	208	1	4.6	6-15P	6-15R
	240	1	4.0	6-15P	6-15R

* Outlet not supplied by Caddy Corporation.

** Height excludes flange & guide posts.
Add 3-1/4" for overall height.

General Specifications

Caddy Magic self-leveling dispenser to be Caddy Corporation model CM-_____.

Unit to have heavy gauge aluminum carrying platform with ball bearing rollers for stable guidance in vertical stainless steel tracks. Carrying platform to have four 3" high plastic guide posts equally spaced. Pan type bottom to be welded to four stainless steel uprights with 16 gauge stainless steel flanged top frame to provide one rigid assembly.

Self-leveling dispenser to be field adjustable without the use of tools for stainless steel underliners and bases without requiring prior identification, irrespective of weight, height, or brand. Calibrating mechanism to have multiple extension springs peripherally suspended from two corresponding sides of top frame. Selective engaging of springs with carrier assembly to permit balancing and dispensing of any load from 20 to 180 pounds.

Cabinet model specifications:

Unit to have 16 gauge stainless steel top with 2" turned down channel edge on 4 sides and welded finished corners. Exterior of cabinet to be stainless steel. Cabinet corners to be reinforced with 16 gauge stainless steel channels and to have full height extruded plastic vertical bumpers.

Bottom of cabinet to be 12 gauge stainless steel, rust resistant metal and to have 2-1/2" diameter center clean-out hole with a removable plug. Unit to be mounted on four 4" diameter swivel type casters with polyurethane tires***.

*** Heated units to be provided with foot brakes on two diagonal casters.

Heated model specifications:

Electrical control box to be stainless steel and installed for easy removal for service. Control box to be furnished with on/off switch, pilot light with infinite Hi-Lo heat control for temperature settings 1 through 9, and a recessed male three-pronged NEMA twist-lock receptacle. Unit to be supplied with a 6'-0" long cord with a NEMA twist-lock female connector at one end and a three prong male plug at the other end. Heating elements of stainless steel, hi-intensity.

Heated units only to be certified by Intertek.



Unit to be provided with the following accessories:

Accessories

- ACC-41** - Caster brakes on two diagonal casters.
- ACC-50** - Perimeter bumpers with replaceable corner bumpers. (Add 1-1/4" to length and width)
- ACC-52** - Vertical corner bumpers only. Easy to replace. (Add 1-1/4" to length and width)
- ACC-63** - 5" diameter swivel casters with polyurethane tires in lieu of 4" diameter swivel casters. (Add 1-1/8" to height)

CADDY CORPORATION
509 Sharptown Road P.O. Box 345
Bridgeport, NJ 08014-0345
Tel: 856-467-4222 Fax: 856-467-5511
internet: www.caddycorp.com

Self-Leveling Dispensers for Cups, Saucers, Glasses, & Bowls Cantilever style



CM-1020-C

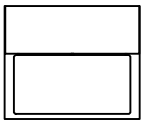

CM-2020-C

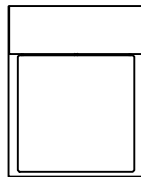

CM-2620-C-10

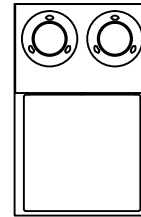

CM-2620-C-20

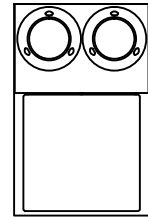

CM-2720-C-10

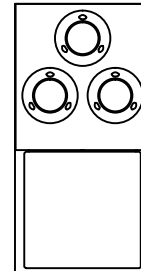

CM-2720-C-20

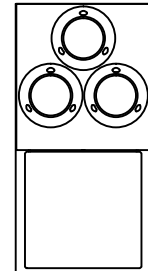
Capacities and Dimensions**

Model	Cups	Glasses	Bowls	Saucers	Length	Width	Height
CM-1020-C	70	95	72	----	23 1/2"	19 5/8"	35 1/2"
CM-2020-C	140	190	144	----	23 1/2"	29 5/8"	35 1/2"
CM-2620-C-10	140	----	----	140	23 1/2"	36 1/4"	35 1/2**
CM-2620-C-20	140	----	----	140	23 1/2"	36 1/4"	35 1/2**
CM-2720-C-10	140	----	----	210	23 1/2"	46 3/4"	35 1/2**
CM-2720-C-20	140	----	----	210	23 1/2"	46 3/4"	35 1/2**

* Height excludes flange & guide posts. Add 3-1/4" for overall height.
** Actual capacities vary with shape of object to be dispensed.

-10 models hold
up to 5-3/4" dia. plates

-20 models hold
5-7/8 to 7-1/4" dia. plates

General Specifications

Caddy Magic self-leveling dispenser to be Caddy Corporation model CM-_____.

Self-leveling mechanism to be cantilevered suspension type. Removable panel to be provided in the 18 gauge stainless steel upright enclosed mechanism housing, to permit easy calibration without the use of tools, for full load factors from 20 to 182 pounds and without prior identification of wares, irrespective of weight, height, or brand. Mechanism to be free of cables, chains, pulleys, sprockets, gears, levers, crank handles or components requiring periodic maintenance and lubrication.

Removable load platform to be 18 gauge stainless steel and secured to 16 gauge stainless steel angle support frame and a pair of cantilevered suspension arms. Suspension arms to be of rust-resistant 1/4" steel and to be securely guided by ball bearing rollers. Total stacking height to top of housing to be not less than 22".

The lower rack storage platform to be formed of 16 gauge stainless steel, channeled down on all four sides with two stainless steel reinforced members underneath. Unit to be mounted on four 4" diameter swivel type casters with polyurethane tires.

Saucer model specifications:

Self-leveling cylinders to be field adjustable without the use of tools for china and plastic saucers without requiring prior identification, irrespective of weight, height, or brand. Calibrating mechanism to have multiple extension springs peripherally suspended from a circular storage bank. Selective engaging of springs with dish carrier assembly to permit balancing and dispensing of any load within range of model selected. Cylinders to have 18 gauge stainless steel raised top flange, in high luster finish, with three 3" high plastic guide posts equally spaced.

Unit to be provided with the following accessories:

Accessories

- ACC-63** - 5" diameter swivel casters with polyurethane tires in lieu of 4" diameter swivel casters. (Add 1-1/8" to height)
- ACC-41** - Caster brakes on two diagonal casters.
- ACC-50** - Perimeter bumpers with replaceable corner bumpers. (Add 1-1/4" to length and width)
- ACC-52** - Vertical corner bumpers only. Easy to replace. (Add 1-1/4" to length and width)

CADDY CORPORATION
509 Sharptown Road P.O. Box 345
Bridgeport, NJ 08014-0345
Tel: 856-467-4222 Fax: 856-467-5511
internet: www.caddycorp.com

Self-Leveling Dispensers for

Trays

Cabinet or Cantilever Style

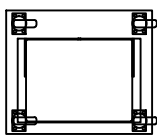
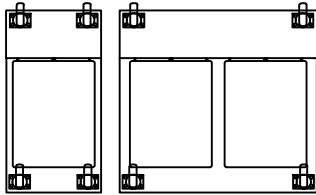
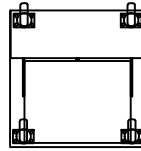
TOP VIEW

TOP VIEW

TOP VIEW

Capacity: 75 trays*

(Actual capacities vary with shape of tray to be dispensed.)

* CM-1814-2C capacity: 150 trays



CM-1418



CM-1814-2C



CM-1418-C

Dimensions

Model	Length	Width	Height	Trays
CM-1418	25 $\frac{3}{8}$ "	21 $\frac{1}{2}$ "	34 $\frac{1}{4}$ "	14" x 18"
CM-1622	27"	23 $\frac{1}{2}$ "	34 $\frac{1}{4}$ "	16" x 22"
CM-1814-C	16 $\frac{1}{2}$ "	31 $\frac{3}{4}$ "	35 $\frac{1}{2}$ "	14" x 18"
CM-2015-C	16 $\frac{1}{2}$ "	31 $\frac{3}{4}$ "	35 $\frac{1}{2}$ "	15" x 20"
CM-2216-C	16 $\frac{1}{2}$ "	31 $\frac{3}{4}$ "	35 $\frac{1}{2}$ "	16" x 22"
CM-1418-C	23 $\frac{1}{2}$ "	23 $\frac{3}{4}$ "	35 $\frac{1}{2}$ "	14" x 18"
CM-1520-C	23 $\frac{1}{2}$ "	23 $\frac{3}{4}$ "	35 $\frac{1}{2}$ "	15" x 20"
CM-1622-C	23 $\frac{1}{2}$ "	24 $\frac{3}{4}$ "	35 $\frac{1}{2}$ "	16" x 22"
CM-1814-2C	34 $\frac{1}{4}$ "	24 $\frac{3}{4}$ "	35 $\frac{1}{2}$ "	14" x 18"

General Specifications

Caddy Magic self-leveling dispenser to be Caddy Corporation model CM-_____.

Self-leveling mechanism to be cantilevered suspension type. Removable panel to be provided to permit easy calibration without the use of tools, for full load factors from 20 to 182 pounds and without prior identification of wares, irrespective of weight, height, or brand. Mechanism to be free of cables, chains, pulleys, sprockets, gears, levers, crank handles or components requiring periodic maintenance and lubrication.

Removable load platform to be 18 gauge stainless steel and secured to 16 gauge stainless steel angle support frame and a pair of cantilevered suspension arms. Suspension arms to be of rust-resistant $\frac{1}{4}$ " steel and to be securely guided by ball bearing rollers. Total stacking height to edge of top frame to be not less than 22".

Cabinet models specifications:

Unit to have 16 gauge stainless steel top with 2" turned down channel edge on 4 sides and welded finished corners. Exterior of cabinet to be stainless steel. Cabinet corners to be reinforced with 16 gauge stainless steel channels and to have full height extruded plastic vertical bumpers.

Bottom of cabinet to be 12 gauge stainless steel, rust resistant metal and to have 2-1/2" diameter center clean-out hole with a removable plug. Unit to be mounted on four 4" diameter swivel type casters with polyurethane tires.

Cantilever models specifications:

The lower rack storage platform to be formed of 16 gauge stainless steel, channeled down on all four sides with two stainless steel reinforce members underneath. Unit to be mounted on four 4" diameter swivel type casters with polyurethane tires.

Unit to be provided with the following accessories:

Accessories

- ACC-63** - 5" diameter swivel casters with polyurethane tires in lieu of 4" diameter swivel casters. (Add 1-1/8" to height)
- ACC-41** - Caster brakes on two diagonal casters.
- ACC-50** - Perimeter bumpers with replaceable corner bumpers. (Add 1-1/4" to length and width)
- ACC-51** - Guides for automatic tray stacking.
- ACC-52** - Vertical corner bumpers only. Easy to replace. (Add 1-1/4" to length and width)

Self-Leveling Dispensers for

Trays & Silver

Cabinet or Cantilever Style



PROJECT:

LOCATION:

CABINET STYLE

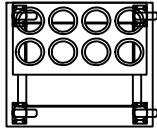

CANTILEVER STYLE

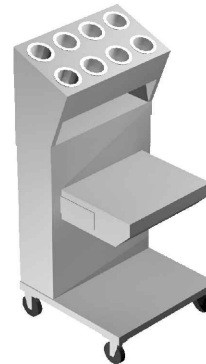

Capacities**

Model	Tray Size	Tray Qty.	Cutlery Cutouts
CM-1418-CS	14" x 18"	75	8
CM-1418-S	14" x 18"	75	8
CM-1622-S	16" x 22"	75	8
CM-1814-CS	14" x 18"	75	6
CM-1814-2CS	14" x 18"	150	12
CM-1814-2CSL	14" x 18"	150	18

** Actual capacities vary with shape of tray and cutlery to be dispensed.

Dimensions

Model	Length	Width	Height
CM-1418-CS	23 1/2"	23"	51 1/4"
CM-1418-S	25 1/2"	21 1/2"	49 3/4"
CM-1622-S	27"	23 1/2"	49 3/4"
CM-1814-CS	16 1/2"	31 3/4"	51 1/4"
CM-1814-2CS	34 1/4"	31 3/4"	51 1/4"
CM-1814-2CSL	34 1/4"	31 3/4"	51 1/4"

General Specifications

Caddy Magic self-leveling dispenser to be Caddy Corporation model CM-_____.

Self-leveling mechanism to be cantilevered suspension type. Removable panel to be provided to permit easy calibration without the use of tools, for full load factors from 20 to 182 pounds and without prior identification of wares, irrespective of weight, height, or brand. Mechanism to be free of cables, chains, pulleys, sprockets, gears, levers, crank handles or components requiring periodic maintenance and lubrication.

Removable load platform to be 18 gauge stainless steel and secured to 16 gauge stainless steel angle support frame and a pair of cantilevered suspension arms. Suspension arms to be of rust-resistant 1/4" steel and to be securely guided by ball bearing rollers. Total stacking height to edge of top frame to be not less than 22".

Unit provided with 20 gauge stainless steel cutlery housing with die-stamped reinforced openings for cutlery cylinders. End enclosures to be 16 gauge stainless steel.

Cabinet models specifications:

Unit to have 16 gauge stainless steel top with 2" turned down channel edge on 4 sides and welded finished corners. Exterior of cabinet to be stainless steel. Cabinet corners to be reinforced with 16 gauge stainless steel channels and to have full height extruded plastic vertical bumpers.

Bottom of cabinet to be 12 gauge stainless steel, rust resistant metal and to have 2-1/2" diameter center clean-out hole with a removable plug. Unit to be mounted on four 4" diameter swivel type casters with polyurethane tires.

Cantilever models specifications:

The lower rack storage platform to be formed of 16 gauge stainless steel, channeled down on all four sides with two stainless steel reinforce members underneath. Unit to be mounted on four 4" diameter swivel type casters with polyurethane tires.

Unit to be provided with the following accessories:

Accessories

- ACC-63** - 5" diameter swivel casters with polyurethane tires in lieu of 4" diameter swivel casters. (Add 1-1/8" to height)
- ACC-41** - Caster brakes on two diagonal casters.
- ACC-49*** - Perforated plastic cutlery cylinders. Approximate capacity per cylinder: 48 knives, 36 forks, or 40 spoons
- ACC-50** - Perimeter bumpers with replaceable corner bumpers. (Add 1-1/4" to length and width)
- ACC-52** - Vertical corner bumpers only. Easy to replace. (Add 1-1/4" to length and width)

* Specify quantity required

CADDY CORPORATION
 509 Sharptown Road P.O. Box 345
 Bridgeport, NJ 08014-0345
 Tel: 856-467-4222 Fax: 856-467-5511
 internet: www.caddycorp.com

Self-Leveling Dispensers for

Trays & Silver

Cabinet or Cantilever Style



PROJECT:

LOCATION:

TOP VIEW

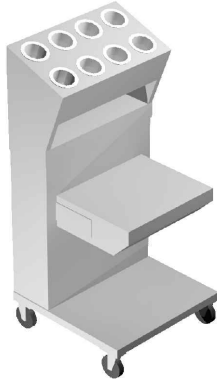
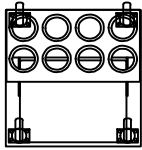

CM-1418-CS

TOP VIEW

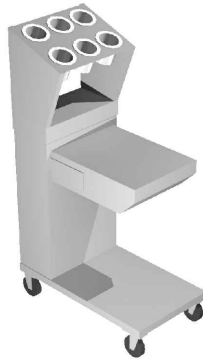
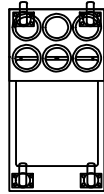

CM-1814-CS

TOP VIEW

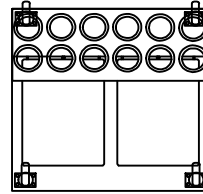

CM-1814-2CS

TOP VIEW

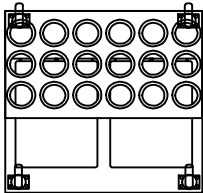

CM-1814-2CSL

TOP VIEW

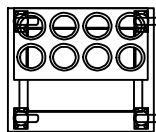

CM-1418-S

TOP VIEW

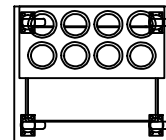

CM-1622-S



CADDY CORPORATION

509 Sharptown Road P.O. Box 345
Bridgeport, NJ 08014-0345
Tel: 856-467-4222 Fax: 856-467-5511
internet: www.caddycorp.com

Self-Leveling Dispensers
Drop-In Style for
Cups, Glasses, & Bowls



DROP-IN SERIES / PLATFORM STYLE

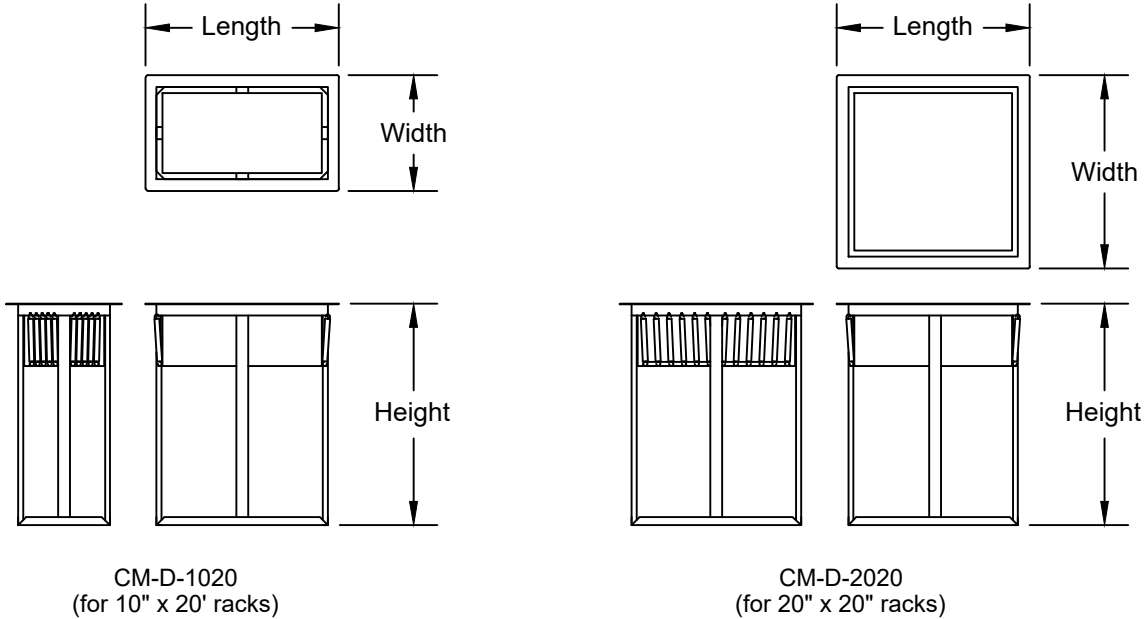

Model	Flange (Length)	Flange (Width)	Overall (Height)	Countertop Cutout (Length)	Countertop Cutout (Width)	Capacity*		
						Cups	Glasses	Bowls
CM-D-1020	24 $\frac{1}{2}$ "	14 $\frac{3}{4}$ "	28"	22 $\frac{1}{4}$ "	12 $\frac{1}{4}$ "	70	95	---
CM-D-2020	24 $\frac{1}{2}$ "	24 $\frac{1}{2}$ "	28"	22"	22"	140	190	96

* Capacities vary with shape of dishware to be dispensed

General Specifications

Caddy Magic self-leveling dispenser to be Caddy Corporation model CM-D-_____.

Unit to have heavy gauge aluminum carrying platform with ball bearing rollers for stable guidance in vertical stainless steel tracks. Pan type bottom to be welded to four stainless steel uprights with 16 gauge stainless steel flanged top frame to provide one rigid assembly.

Self-leveling dispenser to be field adjustable without the use of tools and without requiring prior identification, irrespective of weight, height, or brand. Calibrating mechanism to have multiple extension springs peripherally suspended from two corresponding sides of top frame. Selective engaging of springs with carrier assembly to permit balancing and dispensing of any load from 20 to 180 pounds.

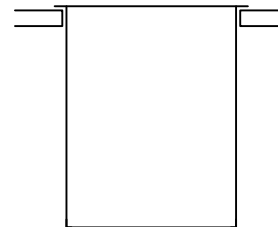

Chassis may overlap the counter top. Suitable method for installation in wood fixtures or stainless steel counter tops.

CADDY CORPORATION
 509 Sharptown Road P.O. Box 345
 Bridgeport, NJ 08014-0345
 Tel: 856-467-4222 Fax: 856-467-5511
 internet: www.caddycorp.com



CADDY CORPORATION

Food Service Equipment

Air Systems

Hot Food Caddys



Hot Food Caddys

Open or Heated Base / Regular or Slimline



REGULAR STRAIGHT

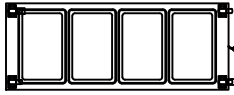

(TF-604 & TF-624 Shown)

FULL CONVENIENCE

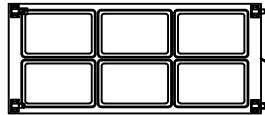

(TF-616 & TF-636 Shown)

SLIMLINE STRAIGHT



(TF-614 & TF-634 Shown)

SLIMLINE L-SHAPED

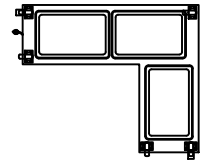

(TF-613-R & TF-633-R Shown)

REGULAR U-SHAPED

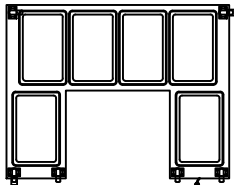

(TF-606-U & TF-626-U Shown)

REGULAR L-SHAPED

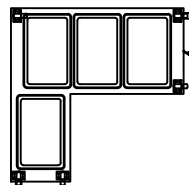

(TF-604-L & TF-624-L Shown)

SLIMLINE U-SHAPED

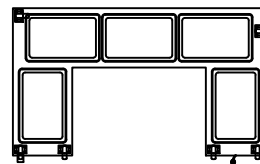

(TF-615-U & TF-635-U Shown)

SLIMLINE L-SHAPED ROTATED WELL

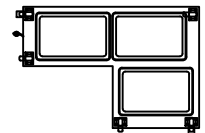

(TF-613-R-R & TF-633-R-R Shown)

There's a Hot Food Caddy for every requirement in the serving of hot foods. Mobile units are available in open or heated base models in both regular units (26" wide) and slimline units (18" wide). All units can be used singularly or in any combination for maximum efficiency in serving each meal.

All Hot Food Caddys feature:

- Full height vertical corner bumpers
- Insulated hot food wells with individual heat control pilot light and thermostatic limit switch
- Tilted control panel for easy operation
- Heavy duty, double ball bearing swivel casters with polyurethane tires.

Heated Base Models also feature:

- Heated compartments with temperature control and pilot light
- Each compartment holds four full size 2 1/2" deep food pans
- Pan slides remove easily without tools for cleaning and storage of 4" and 6" deep pans

General Specifications

Hot Food Caddy to be Caddy Corporation model TF-_____.

Unit to have all stainless steel exterior. Top to be 18 gauge stainless steel turned down into 2" wide channel edges, with corners welded. Openings for hot food wells to be die formed with 1" wide, raised pan rest around perimeter of opening. Pan rest to be 1/8" above table top and turned down into food wells. Joints between top and wells to be provided with moisture and thermal breaker.

Hot food wells to measure 12" x 20" x 6-3/8" deep, of seamless drawn stainless steel with coved corners, fully insulated and encased in separate metal housing. Each hot food well to be provided with a heating element of not less than 1 KW, hi-heat thermostatic limit switch, pilot light and infinite heat control allowing operator to select and stabilize any level of holding heat from 0 to maximum input. Infinite heat control and pilot light for each well to be recessed in easy-to-observe tilted front panel. Wells to be for moist and dry heat operation and to accommodate full or partial size pans up to 6" deep.*

Frame structure to consist of 18 gauge stainless steel formed pedestals to be reinforced with 16 gauge stainless steel channels, to have full height extruded plastic vertical bumpers. Casters are to be 4" diameter heavy duty, double ball bearing, swivel type with polyurethane tires. Two casters to be provided with foot brakes. Unit to be completely wired and provided with a 6'-0" long cord and plug located on side specified at time of order.

* Pans and covers not included.

Continue specifications for

Heated Base Models

Lower food storage compartments constructed of 20 gauge stainless steel with fully insulated wells. Cabinet door with front-face gray laminate for extra heat protection, recessed handle and automatic latch.

Compartments to be heated with stainless convecter type heat of not less than 350 W complete with infinite heat control and pilot light to be mounted and recessed in an easy-to-observe tilted front panel. Each compartment fitted on inside with a stainless steel wire pan frame with four pan slides on 3" centers. Pan slides to accommodate standard 12" wide food pans and to be removable, without the use of tools, for cleaning.

CADDY CORPORATION
 509 Sharptown Road P.O. Box 345
 Bridgeport, NJ 08014-0345
 Tel: 856-467-4222 Fax: 856-467-5511
 internet: www.caddycorp.com



Hot Food Caddys

Open or Heated Base / Regular or Slimline



Unit to be provided with the following accessories:
(excluding TF-616 & TF-636 units)

Accessories

Folding Tray Slide - To be 1" square 16 gauge stainless steel tubing, 10" overall width, welded to intermediate lateral supports and mounted on control side on folding brackets. Slide to be removable.

	2 Well	3 Well	4 Well
26" wide units	<input type="checkbox"/> A-68	<input type="checkbox"/> A-69	<input type="checkbox"/> A-70
18" wide units	<input type="checkbox"/> A-88	<input type="checkbox"/> A-89	

Folding Work Shelf - 16 gauge stainless steel with all edges turned down and welded corners, 10" overall width, mounted on control side on folding brackets. Shelf to be removable.

	2 Well	3 Well	4 Well
26" wide units	<input type="checkbox"/> A-72	<input type="checkbox"/> A-73	<input type="checkbox"/> A-74
18" wide units	<input type="checkbox"/> A-90	<input type="checkbox"/> A-91	

Infrared Warmer* - High intensity infrared elements recessed in overhead enclosure 10" x 3" deep. Enclosure supported at both ends by 1-1/4" square tubular upright. Furnished with pilot light and on/off switch. Infrared Warmer compensates for surface heat loss.

	2 Well	3 Well	4 Well
26" wide units	<input type="checkbox"/> A-1 800 Watts	<input type="checkbox"/> A-2 1100 Watts	<input type="checkbox"/> A-3 1400 Watts
18" wide units	<input type="checkbox"/> A-2 1100 Watts	<input type="checkbox"/> A-3 1725Watts	

Undershelf** - To be 18 gauge stainless steel with channel reinforced longitudinal edges, located 7" above floor and secured to pedestals at both ends.

	2 Well	3 Well	4 Well
26" wide units	<input type="checkbox"/> A-92	<input type="checkbox"/> A-93	<input type="checkbox"/> A-94
18" wide units	<input type="checkbox"/> A-95	<input type="checkbox"/> A-96	

Overshelf - To be 16 gauge stainless steel, 10" wide with channel edges. Supports to be 1" x 1/4" flat bar. Shelf to be located rear of unit 15" above work top.

	2 Well	3 Well	4 Well
26" wide units	<input type="checkbox"/> A-64	<input type="checkbox"/> A-65	<input type="checkbox"/> A-66
18" wide units	<input type="checkbox"/> A-86	<input type="checkbox"/> A-87	

Sneeze Protector*** - To be 3/16" clear polycarbonate plastic, suspended from 16 gauge stainless steel overshelf.

	2 Well	3 Well	4 Well
26" wide units	<input type="checkbox"/> A-60	<input type="checkbox"/> A-61	<input type="checkbox"/> A-62
18" wide units	<input type="checkbox"/> A-84	<input type="checkbox"/> A-85	

Extra Outlet**** - To be located on lower portion of end panel opposite electric supply cord. Fused outlet to be 2 pole with ground prong.

A-6 - 10 Amp for 120 volts
 A-7 - 6 Amp for 240 volts

Push Handle - To be 1" O.D. 16 gauge stainless steel tubing with two 16 gauge stainless steel support brackets and 3" neoprene donut bumpers. Specify which end, when facing control panel, at time of order.

26" wide units A-15
 18" wide units A-16

ACC-52 - Vertical corner bumpers only. Easy to replace.
 (Add 1-1/4" to length and width)

TF-616 & TF-636 units to be provided with the following accessories:

Accessories

Infrared Warmer* - High intensity infrared elements recessed in overhead enclosure 10" x 3" deep. Enclosure supported at both ends by 1-1/4" square tubular upright. Furnished with pilot light and on/off switch. Infrared Warmer compensates for surface heat loss.

	3 Well
33" wide units	<input type="checkbox"/> A-3 1725Watts

Extra Outlet**** - To be located on lower portion of end panel opposite electric supply cord. Fused outlet to be 2 pole with ground prong.

A-6 - 10 Amp for 120 volts
 A-7 - 6 Amp for 240 volts

Push Handle - To be 1" O.D. 16 gauge stainless steel tubing with two 16 ga. stainless steel support brackets and 3" neoprene donut bumpers. Specify which end, when facing control panel, at time of order.

33" wide units A-13

ACC-52 - Vertical corner bumpers only. Easy to replace.
 (Add 1-1/4" to length and width)

A-98 - Manifold Welded Copper Drains to Ball Valve.

* Not available with sneeze protector
 ** For open base models only.

*** Includes overshelf.
 **** One outlet per unit only.

CADDY CORPORATION
 509 Sharptown Road P.O. Box 345
 Bridgeport, NJ 08014-0345
 Tel: 856-467-4222 Fax: 856-467-5511
 internet: www.caddycorp.com



Hot Food Caddys

Open or Heated Base / Regular or Slimline

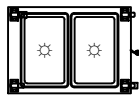

TOP VIEW

 TF-602
TF-622

TOP VIEW

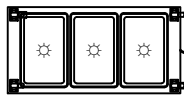
 TF-603
TF-623

TOP VIEW

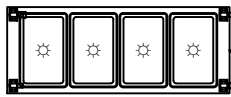
 TF-604
TF-624

TF-602



TF-603



TF-604



TF-622



TF-623



TF-624

TOP VIEW

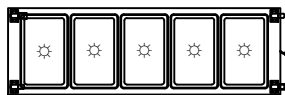
 TF-605
TF-625

TOP VIEW

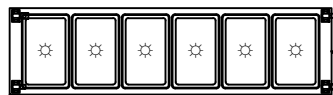
 TF-606
TF-626

TF-605



TF-606



TF-625



TF-626

TOP VIEW

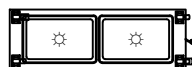
 TF-612
TF-632

TOP VIEW

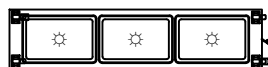
 TF-613
TF-633

TOP VIEW

 TF-614
TF-634

TF-612



TF-613



TF-614



TF-632



TF-633



TF-634

Dimensions

	Model	Length	Width	Height
Two Well Units	TF-602	37"	26"	34"
	TF-612	53"	18"	34"
	TF-622	37"	26"	34"
	TF-632	53"	18"	34"
Three Well Units	TF-603	52"	26"	34"
	TF-613	76"	18"	34"
	TF-623	52"	26"	34"
Four Well Units	TF-604	67"	26"	34"
	TF-614	99"	18"	34"
	TF-624	67"	26"	34"
Five Well	TF-605	82"	26"	34"
	TF-625	82"	26"	34"
Six Well	TF-606	97"	26"	34"
	TF-626	97"	26"	34"

☼ Denotes location of heated compartment when applicable

CADDY CORPORATION
 509 Sharptown Road P.O. Box 345
 Bridgeport, NJ 08014-0345
 Tel: 856-467-4222 Fax: 856-467-5511
 internet: www.caddycorp.com



Hot Food Caddys

Open or Heated Base / Regular or Slimline

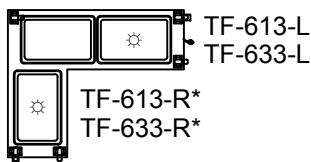

TOP VIEW

 TF-613-L
TF-613R*

 TF-633-L
TF-633-R*

TOP VIEW

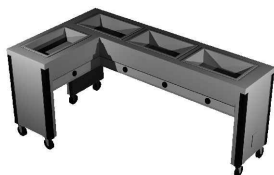
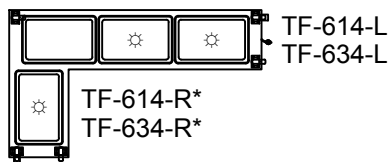
 TF-614-L
TF-614R*

 TF-634-L
TF-634-R*

TOP VIEW

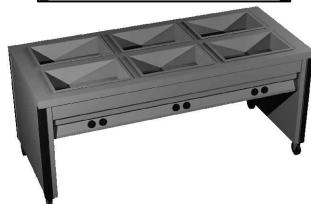
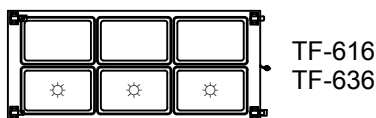

TF-616



TF-636

TOP VIEW

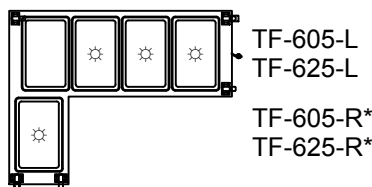
 TF-605-L
TF-605R*

 TF-625-L
TF-625-R*

TOP VIEW

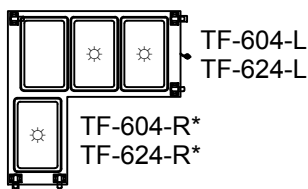
 TF-604-L
TF-604R*

 TF-624-L
TF-624-R*

TOP VIEW

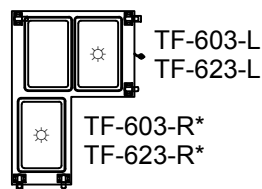
 TF-603-L
TF-603R*

 TF-623-L
TF-623-R*

Dimensions

	Model	Length	Width	Height
Three Well Units	TF-603-L	37"	52 ¹ / ₄ "	34"
	TF-603-R	37"	52 ¹ / ₄ "	34"
	TF-613-L	53"	44 ³ / ₈ "	34"
	TF-613-R	53"	44 ³ / ₈ "	34"
	TF-623-L	37"	52 ¹ / ₄ "	34"
	TF-623-R	37"	52 ¹ / ₄ "	34"
	TF-633-L	53"	44 ³ / ₈ "	34"
Four Well Units	TF-604-L	52"	52 ¹ / ₄ "	34"
	TF-604-R	52"	52 ¹ / ₄ "	34"
	TF-614-L	76"	44 ³ / ₈ "	34"
	TF-614-R	76"	44 ³ / ₈ "	34"
	TF-624-L	52"	52 ¹ / ₄ "	34"
	TF-624-R	52"	52 ¹ / ₄ "	34"
	TF-634-L	76"	44 ³ / ₈ "	34"
Five Well Units	TF-605-L	67"	52 ¹ / ₄ "	34"
	TF-605-R	67"	52 ¹ / ₄ "	34"
	TF-615-L	76"	51 ¹ / ₂ "	34"
	TF-615-R	76"	51 ¹ / ₂ "	34"
	TF-625-L	67"	52 ¹ / ₄ "	34"
	TF-625-R	67"	52 ¹ / ₄ "	34"
	TF-635-L	76"	51 ¹ / ₂ "	34"
Six Well	TF-616	76"	33"	34"
	TF-636	76"	33"	34"

* Right hand model is a mirror image of the model shown
 ✧ Denotes location of heated compartment when applicable

CADDY CORPORATION
 509 Sharptown Road P.O. Box 345
 Bridgeport, NJ 08014-0345
 Tel: 856-467-4222 Fax: 856-467-5511
 internet: www.caddycorp.com



Hot Food Caddys

Open or Heated Base / Regular or Slimline



TOP VIEW

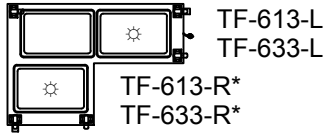

TF-613-L
TF-633-L

TF-613-R*
TF-633-R*



TF-613-L
TF-613-R*



TF-633-L
TF-633-R*

TOP VIEW

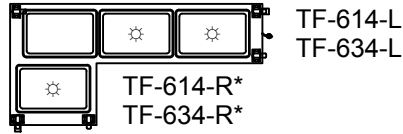

TF-614-L
TF-634-L

TF-614-R*
TF-634-R*



TF-614-L
TF-614-R*



TF-634-L
TF-634-R*

TOP VIEW

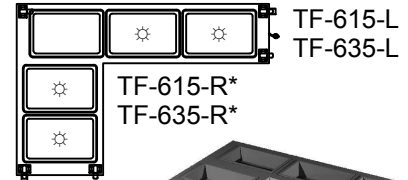

TF-615-L
TF-635-L

TF-615-R*
TF-635-R*



TF-615-L
TF-615-R*



TF-635-L
TF-635-R*

TOP VIEW

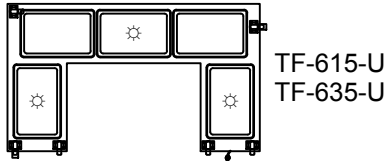

TF-615-U
TF-635-U



TF-615-U

TOP VIEW

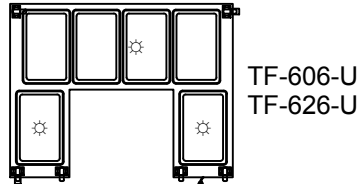

TF-606-U
TF-626-U



TF-606-U



TF-635-U



TF-626-U

Dimensions

	Model	Length	Width	Height
Three Well Units	TF-613-L	53"	36 $\frac{1}{2}$ "	34"
	TF-613-R	53"	36 $\frac{1}{2}$ "	34"
	TF-633-L	53"	36 $\frac{1}{2}$ "	34"
	TF-633-R	53"	36 $\frac{1}{2}$ "	34"
Four Well Units	TF-614-L	53"	36 $\frac{1}{2}$ "	34"
	TF-614-R	53"	36 $\frac{1}{2}$ "	34"
	TF-634-L	53"	36 $\frac{1}{2}$ "	34"
	TF-634-R	53"	36 $\frac{1}{2}$ "	34"
Five Well Units	TF-615-L	76"	51 $\frac{1}{2}$ "	34"
	TF-615-R	76"	51 $\frac{1}{2}$ "	34"
	TF-615-U	76"	44 $\frac{3}{8}$ "	34"
	TF-635-L	76"	51 $\frac{1}{2}$ "	34"
	TF-635-R	76"	51 $\frac{1}{2}$ "	34"
	TF-635-U	76"	44 $\frac{3}{8}$ "	34"
Six Well	TF-606-U	67"	52 $\frac{1}{4}$ "	34"
	TF-626-U	67"	52 $\frac{1}{4}$ "	34"

* Right hand model is a mirror image of the model shown
 ☼ Denotes location of heated compartment when applicable



Hot Food Caddys

Open or Heated Base / Regular or Slimline



TF-602, TF-612				
		Base Unit	-A6	-A7
Volts	φ	Amp	Amp	Amp
208	1	11.4		17.4
240		10.0		16.0
120/208			21.4	
120/240			20.0	
208	3			6.9
240				6.8
120/208			13.3	
120/240			12.9	

TF-603, 603-L, 603-R, 613, 613-L, 613-R, 613-L-R, 613-R-R				
		Base Unit	-A6	-A7
Volts	φ	Amp	Amp	Amp
208	1	17.3		23.3
240		15.00		21.0
120/208			27.3	
120/240			25.0	
208	3	14.7		12.4
240		12.9		11.7
120/208			12.6	
120/240			10.8	

TF-604, 604-L, 604-R, 614, 614-L, 614-R, 614-L-R, 614-R-R				
		Base Unit	-A6	-A7
Volts	φ	Amp	Amp	Amp
208	1	23.0		29.0
240		20.0		26.0
120/208			33.8	
120/240			30.0	
208	3	18.3		15.4
240		15.8		13.3
120/208			18.3	
120/240			15.7	

TF-605, 605-L, 605-R, 615-L, 615-R, 615-U				
		Base Unit	-A6	-A7
Volts	φ	Amp	Amp	Amp
208	1	28.8		34.8
240		25.0		31.0
120/208			38.8	
120/240			35.0	
208	3	15.7		14.0
240		13.6		12.5
120/208			20.0	
120/240			18.6	

TF-606, 606-U, 616				
		Base Unit	-A6	-A7
Volts	φ	Amp	Amp	Amp
208	1	34.6		
240		30.0		
120/208				
120/240				
208	3	17.2		21.7
240		13.6		19.6
120/208			25.6	
120/240			23.6	

TF-622				
		Base Unit	-A6	-A7
Volts	φ	Amp	Amp	Amp
208	1	13.9		19.9
240		13.0		19.0
120/208			23.9	
120/240			23.0	
208	3	7.9		9.2
240		6.6		9.8
120/208			13.3	
120/240			17.1	

TF-623, 623-L, 623-R				
		Base Unit	-A6	-A7
Volts	φ	Amp	Amp	Amp
208	1	20.9		26.9
240		19.5		25.5
120/208			30.9	
120/240			29.5	
208	3	13.0		15.0
240		11.0		14.2
120/208			13.6	
120/240			17.8	

TF-624, 624-L, 624-R, 634, 634-L, 634-R, 634-L-R, 634-R-R				
		Base Unit	-A6	-A7
Volts	φ	Amp	Amp	Amp
208	1	27.8		33.8
240		26.0		32.0
120/208			37.8	
120/240			36.0	
208	3	15.2		13.9
240		14.7		13.1
120/208			18.2	
120/240			19.7	

TF-625, 625-L, 625-R, 635-L, 635-R				
		Base Unit	-A6	-A7
Volts	φ	Amp	Amp	Amp
208	1	34.8		
240		32.5		
120/208				
120/240				
208	3	21.5		23.0
240		23.0		24.0
120/208			23.5	
120/240			24.7	



CADDY CORPORATION

Food Service Equipment

Air Systems

Cold Food Caddys

Cold Food Caddys

Regular or Slimline



Uniquely designed, with special wells, to assure consistent food temperatures. Excellent for Cook-Chill systems or plating cold food. Far superior to ordinary cold food equipment. Foods placed in these units will remain at constant temperatures until ready for reconstitution or serving.

REGULAR



(RIF-604 Shown)

SLIMLINE

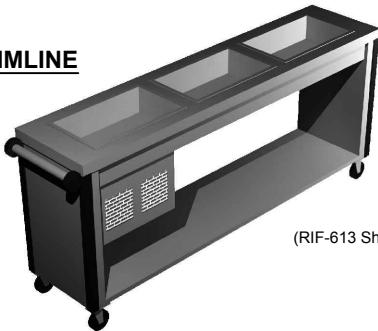

(RIF-613 Shown)

General Specifications

Cold Food Caddy to be Caddy Corporation model RIF-_____.

Unit to have all stainless steel exterior. Top to be 18 gauge stainless steel turned down into 2" wide channel edges, with corners welded. Each opening for cold food wells to be die formed with 1" wide, 1/8" high, raised pan rest around perimeter of opening. Top turndown into cold bain marie with a thermal breaker under turndown on all sides. Unit to be provided with 1/4 hp, 120V, 60Hz, 1PH compressor with thermal overload protection and on/off switch.

Cold food wells to measure 12" x 20" x 4-5/8" deep, of seamless drawn stainless steel with cove corners, fully insulated with copper coils and encased in separate metal housing. Wells to accommodate full or partial size pans up to 4" deep.*

Frame structure to consist of 18 gauge stainless steel formed pedestals to be reinforced with 16 gauge stainless steel channels, to have full height extruded plastic vertical bumpers. Casters are to be 4" diameter heavy duty, double ball bearing, swivel type with polyurethane tires. Two casters to be provided with foot brakes. Unit to be completely wired and provided with a 6'-0" long cord and plug located at rear of unit from worker's side.

* Pans not included.

Unit to be provided with the following accessories:

Accessories

Folding Tray Slide - To be 1" square 16 gauge stainless steel tubing, 10" overall width, welded to intermediate lateral supports and mounted on control side on folding brackets. Slide to be removable.

	2 Well	3 Well	4 Well
26" wide units	<input type="checkbox"/> A-68	<input type="checkbox"/> A-69	<input type="checkbox"/> A-70
18" wide units	<input type="checkbox"/> A-88	<input type="checkbox"/> A-89	

Folding Work Shelf - 16 gauge stainless steel with all edges turned down and welded corners, 10" overall width, mounted on control side on folding brackets. Shelf to be removable.

	2 Well	3 Well	4 Well
26" wide units	<input type="checkbox"/> A-72	<input type="checkbox"/> A-73	<input type="checkbox"/> A-74
18" wide units	<input type="checkbox"/> A-90	<input type="checkbox"/> A-91	

Undershelf - To be 18 gauge stainless steel with channel reinforced longitudinal edges, located 7" above floor and secured to pedestals at both ends.

	2 Well	3 Well	4 Well
26" wide units	<input type="checkbox"/> A-92	<input type="checkbox"/> A-93	<input type="checkbox"/> A-94
18" wide units	<input type="checkbox"/> A-95	<input type="checkbox"/> A-96	

Overshelf - To be 16 gauge stainless steel, 10" wide with channel edges. Supports to be 1" x 1/4" flat bar. Shelf to be located at rear of unit 15" above work top.

	2 Well	3 Well	4 Well
26" wide units	<input type="checkbox"/> A-64	<input type="checkbox"/> A-65	<input type="checkbox"/> A-66
18" wide units	<input type="checkbox"/> A-86	<input type="checkbox"/> A-87	

Sneeze Protector** - To be 3/16" clear polycarbonate plastic, suspended from 16 gauge stainless steel overshelf.

	2 Well	3 Well	4 Well
26" wide units	<input type="checkbox"/> A-60	<input type="checkbox"/> A-61	<input type="checkbox"/> A-62
18" wide units	<input type="checkbox"/> A-84	<input type="checkbox"/> A-85	

Push Handle - To be 1" O.D. 16 gauge stainless steel tubing with two 16 gauge stainless steel support brackets and 3" neoprene donut bumpers. Specify which end, when facing control panel, at time of order.

26" wide units	<input type="checkbox"/> A-15
18" wide units	<input type="checkbox"/> A-16

ACC-52 - Vertical corner bumpers only. Easy to replace. (Add 1-1/4" to length and width)

** Includes overshelf.

CADDY CORPORATION
 509 Sharptown Road P.O. Box 345
 Bridgeport, NJ 08014-0345
 Tel: 856-467-4222 Fax: 856-467-5511
 internet: www.caddycorp.com

Cold Food Caddys

Regular or slimline



All Cold Food Caddys feature:

- Full height vertical corner bumpers
- Insulated cold food wells with coils
- Thermostat control
- Heavy duty, double ball bearing swivel casters with polyurethane tires.

RIF-602

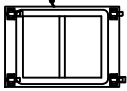

RIF-603

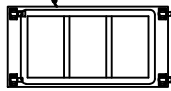

RIF-604

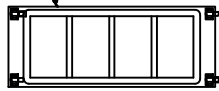

RIF-605

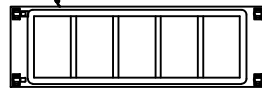

RIF-606

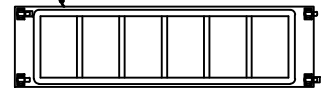

Dimensions			
Model	Length	Width	Height
RIF-602	37"	26"	34 1/2"
RIF-603	52"	26"	34 1/2"
RIF-604	67"	26"	34 1/2"
RIF-605	82"	26"	34 1/2"
RIF-606	97"	26"	34 1/2"

Electrical Data				NEMA	
Model	Volts	Phase	Amps	Plug	Outlet *
RIF-602	120	1	5.8	5-15P	5-15R
RIF-603	120	1	5.8	5-15P	5-15R
RIF-604	120	1	5.8	5-15P	5-15R
RIF-605	120	1	8.8	5-15P	5-15R
RIF-606	120	1	8.8	5-15P	5-15R

* Outlet not supplied by Caddy Corporation.

RIF-612

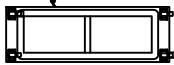

RIF-613

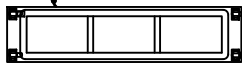

RIF-614

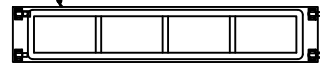

Dimensions			
Model	Length	Width	Height
RIF-612	53"	18"	34 1/2"
RIF-613	76"	18"	34 1/2"
RIF-614	99"	18"	34 1/2"

Electrical Data				NEMA	
Model	Volts	Phase	Amps	Plug	Outlet *
RIF-612	120	1	5.8	5-15P	5-15R
RIF-613	120	1	5.8	5-15P	5-15R
RIF-614	120	1	5.8	5-15P	5-15R

* Outlet not supplied by Caddy Corporation.



CADDY CORPORATION

509 Sharptown Road P.O. Box 345
 Bridgeport, NJ 08014-0345
 Tel: 856-467-4222 Fax: 856-467-5511
 internet: www.caddycorp.com



CADDY CORPORATION

Food Service Equipment

Air Systems

Tray Delivery Trucks

Tray Delivery Trucks with Single, double, or triple doors on front or with Single or double doors on both front and back



Single Door
(TD-607-D-14 shown)



Double Door
(TD-614-D-14 shown)



Triple Door
(TD-621-D-14 shown)



All Caddy Tray Delivery Trucks feature: Sides, doors, and inside tray slides of super impact polymer that resists stains and cracking from detergents. Inside tray slides are formed with large radius corners and set 2" away from front and back for easy cleaning. No disassembly required. No sharp inside corners which prevents food and grime build-up. All double walls and openings are sealed against water and vermin infestation. Doors swing open 270° against the side of the truck. The latches are 300 series stainless steel airline type with positive cam lock to prevent the doors from opening when moving across thresholds.

Caddy TD-600 Series Tray Delivery Trucks are available in 5 colors

TDC Series available in Cream only.

General Specifications

Tray Delivery Truck to be Caddy Corporation model TD-_____.

Unit to have stainless steel top, back and chassis. Ends and partition to be of high-impact, double wall polymer with molded seamless tray supports. Spacing between tray supports to be 5 1/4". One end provided with card holder and 1" O.D. seamless stainless steel handle. Card holder to be fitted with sure grip roller assembly for easy insertion and removal of identification card.

Bottom platform to be 16 gauge stainless steel with stainless steel channel braces. The perimeter to be furnished with full non-marking bumper in stainless steel channel with separate replaceable corners. Unit to be mounted on four 6" diameter* heavy duty, double ball bearing, casters with polyurethane tires. Two casters to be swivel type and two to be rigid type.

Exterior of Tray Delivery Truck to be finished in (select one).

- Cream & Blue
 Cream & Cranberry
 Cream
 Cream & Teal
 Cream & Gray

* Model TD-607-D, TD-614-D, & TD-21-D are mounted on 5" diameter casters

Single Door					
Model	Length	Width	Height	Trays	Net. Wt.
TD-607-D**	23 3/8"	26 3/4"	47"	7	150 lbs.
TD-608-D**	23 3/8"	26 3/4"	53 1/2"	8	150 lbs.
TD-610-D**	23 3/8"	26 3/4"	64"	10	150 lbs.

** Add to the model □-14 for 14" x 18" trays, -15 for 15" x 20" trays, or -16 for 16" x 22" trays

Double Door					
Model	Length	Width	Height	Trays	Net. Wt.
TD-614-D**	41 1/4"	26 3/4"	47"	14	175 lbs.
TD-616-D**	41 1/4"	26 3/4"	53 1/2"	16	175 lbs.
TD-620-D**	41 1/4"	26 3/4"	64"	20	220 lbs.

** Add to the model □-14 for 14" x 18" trays, -15 for 15" x 20" trays, or -16 for 16" x 22" trays

Triple Door					
Model	Length	Width	Height	Trays	Net. Wt.
TD-621-D**	60 1/8"	26 3/4"	47"	21	250 lbs.
TD-624-D**	60 1/8"	26 3/4"	53 1/2"	24	250 lbs.
TD-630-D**	60 1/8"	26 3/4"	64"	30	300 lbs.

** Add to the model □-14 for 14" x 18" trays, -15 for 15" x 20" trays, or -16 for 16" x 22" trays

CADDY CORPORATION
 509 Sharptown Road P.O. Box 345
 Bridgeport, NJ 08014-0345
 Tel: 856-467-4222 Fax: 856-467-5511
 internet: www.caddycorp.com

Tray Delivery Trucks with
Single, double, or triple doors on front or with
Single or double doors on both front and back

PROJECT:

LOCATION:

Unit to be provided with the following accessories:

Accessories

- ACC-17** - Pull handle at both ends of truck.
- ACC-19** - Door stay open compression device.
- ACC-21** - Top perimeter rail around truck.
- ACC-45** - Vertical corner bumpers to protect rear corners.
- ACC-61** - Pair of brakes for 6" diameter casters.
- ACC-62** - Pair of brakes for 8" diameter casters.
- ACC-65** - 8" diameter casters with polyurethane tires.
- ACC-76** - 8" diameter carpet casters with polyurethane tires.
- ACC-77** - 6" diameter stainless steel, non-corrosive casters with polyurethane tires.
- ACC-78** - 6" diameter stainless steel, non-corrosive casters with polyurethane tires.
- ACC-80** - Coupling Device.
- ACC-84** - Compartment drain.
- ACC-85** - Six 6" diameter casters in lieu of four 6" diameter casters.
- ACC-86** - Six 8" diameter casters in lieu of four 8" diameter casters.
- ACC-87** - 6" diameter quiet-ride special modulus casters.
- ACC-88** - 8" diameter quiet-ride special modulus casters.

Tray Delivery Trucks with Single, double, or triple doors on front or with Single or double doors on both front and back



ITEM NO:

PROJECT:

LOCATION:



TD-607-D-14
TD-607-D-15
TD-607-D-16



TD-614-D-14
TD-614-D-15
TD-614-D-16



TD-621-D-14
TD-621-D-15
TD-621-D-16



TD-608-D-14
TD-608-D-15
TD-608-D-16



TD-616-D-14
TD-616-D-15
TD-616-D-16



TD-624-D-14
TD-624-D-15
TD-624-D-16



TD-610-D-14
TD-610-D-15
TD-610-D-16



TD-620-D-14
TD-620-D-15
TD-620-D-16



TD-630-D-14
TD-630-D-15
TD-630-D-16



CADDY CORPORATION

Food Service Equipment

Air Systems

Transfer, Storage, and Bussing Caddys

Tray & Silver Caddys for Cafeteria Self-Service with Cylinder-Type Silverware Dispensers

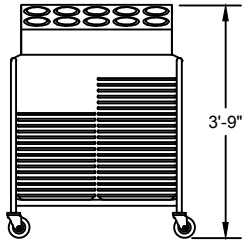
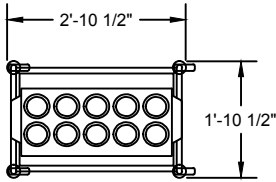

T-402
Capacity:
10 Cutlery Cylinders
190 Trays up to 15" x 20"

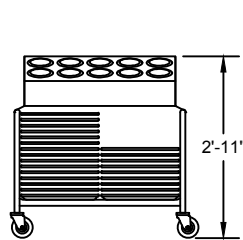
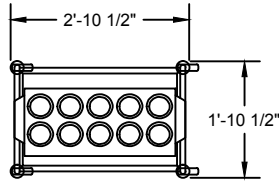

T-404
Capacity:
10 Cutlery Cylinders
120 Trays up to 15" x 20"

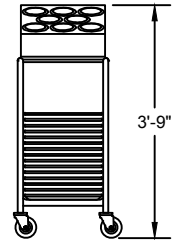
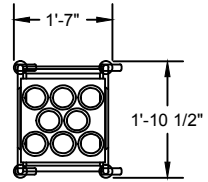

T-414
Capacity:
8 Cutlery Cylinders
195 Trays up to 15" x 20"

General Specifications

Tray & Silver Caddy to be Caddy Corporation model
T-_____.

Frame to be of 1" O.D. 16 gauge stainless steel. Shelf to be 8" above the floor, of 18 gauge stainless steel with raised rounded edges on all sides, flanged down to form a 1-1/2" wide channel. Shelf corners shaped to fit contour of tubular frame and continuously welded to each leg at all contact points, which eliminates unsanitary crevices. Casters to be 4" diameter heavy-duty swivel type with 3/4" stems and polyurethane tires. Housing for cutlery receptacles to be of 18 gauge stainless steel with 16 gauge stainless steel end enclosures and supports of all welded construction. Top of cutlery housing provided with die-stamped reinforced openings for standard perforated plastic cutlery cylinders.

Unit to be provided with the following accessories:

Accessories

- ACC-36** - Removable stainless steel napkin dispenser affixed to side of cutlery housing.
- ACC-37**** - Fold away auxiliary shelf to be 9-1/2" wide, of 16 gauge stainless steel. Available on either or both sides.
- ACC-38** - set of four circular leg bumpers. (Add 4" to length and width)
- ACC-41** - Caster brakes on two diagonal casters.
- ACC-47*** - Vinyl cover encloses entire caddy down to just below under shelf.
- ACC-49**** - Perforated plastic cutlery cylinders. Approximate capacity per cylinder: 48 knives, 36 forks, or 40 spoons.

* Specify for which model
** Specify quantity required

CADDY CORPORATION
509 Sharptown Road P.O. Box 345
Bridgeport, NJ 08014-0345
Tel: 856-467-4222 Fax: 856-467-5511
internet: www.caddycorp.com

Tray & Silver Caddys

Mobile Units with Pan-Type Silverware Dispensers
and Counter Top Units

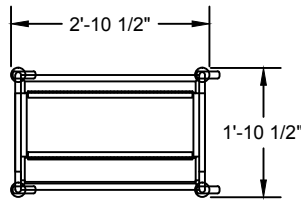
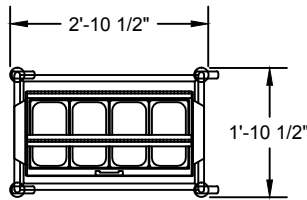
T-301

Capacity:
40 Dozen Cutlery Pieces
190 Trays up to 15" x 20"
Height : 3' 8"

T-303

Capacity:
80 Dozen Cutlery Pieces
190 Trays up to 15" x 20"
Height: 4' 2-1/4"

Mobile Unit General Specifications

Tray & Silver Caddy to be Caddy Corporation model T-_____.

Frame to be of 1" O.D. 16 gauge stainless steel. Shelf to be 8" above the floor, of 18 gauge stainless steel with raised rounded edges on all sides, flanged down to form a 1-1/2" wide channel. Shelf corners shaped to fit contour of tubular frame and continuously welded to each leg at all contact points, which eliminates unsanitary crevices. Casters to be 4" diameter heavy-duty swivel type with 3/4" stems and polyurethane tires. Housing for cutlery receptacles to be of 18 gauge stainless steel with 16 gauge stainless steel end enclosures and supports of all welded construction.

T-301 specifications:

Cutlery housing fitted with double folding covers of fiberglass reinforced plastic with 18 gauge stainless steel hinges. Unit to be furnished with four removable pans. Pans to be seamless 304 type stainless with No. 4 finish. Each pan to measure 11-1/2" x 6" x 4" deep.

T-303 specifications:

Cutlery housing to have front and back folding covers of fiberglass reinforced plastic with 18 gauge stainless steel hinges. Unit to be furnished with eight removable pans. Pans to be seamless 304 type stainless with No. 4 finish. Each pan to measure 11-1/2" x 6" x 4" deep.

Counter Top General Specifications

Counter Top Cutlery Dispenser to be Caddy Corporation model T-_____. Unit to be 20 gauge stainless steel with 16 gauge stainless steel end enclosures and supports of all welded construction and set on non-slip rubber feet.

T-400

Capacity:
10 Cutlery Cylinders

T-400 specifications:

Sloped top provided with ten tie-stamped reinforced openings for standard perforated plastic cutlery cylinders.

Unit to be provided with the following accessories:

Accessories

- ACC-49*** - Perforated plastic cutlery cylinders. Approximate capacity per cylinder: 48 knives, 36 forks, or 40 spoons.

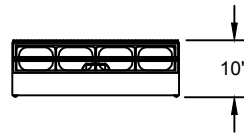
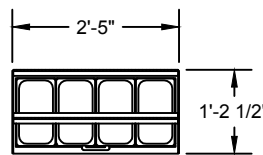

T-320 specifications:

Unit to be fitted with double folding covers of fiberglass reinforced plastic with 18 gauge stainless steel hinges. Unit to be furnished with four removable pans. Pans to be seamless 304 type stainless with No. 4 finish. Each pan to measure 11-1/2" x 6" x 4" deep.

T-320

Capacity:
40 Dozen Cutlery Pieces

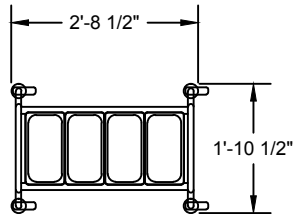

* Specify quantity required

Bulk Silver Caddys
Pan-Type and Cylinder-Type

T-305
Capacity:
120 Dozen Cutlery Pieces
Height □ 2' 6-3/4"

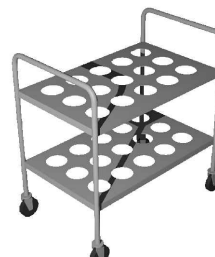
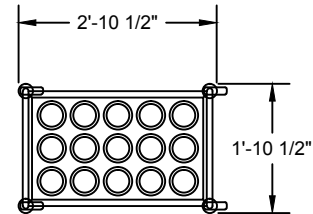

T-407
Capacity:
30 Cutlery Cylinders
Height □ 2' 10-3/4"

Provide bulk storage, transportation and dispensing in cafeterias, dining rooms, and banquet rooms for waiters or patron self service.

General Specifications

Bulk Silver Caddy to be Caddy Corporation model T-_____.

Continue for

T-305 specifications:

Frame to be 1" O.D. 16 gauge stainless steel tubular construction. Casters to be 4" diameter heavy-duty swivel type with 3/4" stems and polyurethane tires.

Shelves to be of 12 gauge stainless steel entirely welded seamlessly with cutouts. Shelf corners shaped to fit contour of tubular frame and continuously welded to each leg at all contact points, which eliminates unsanitary crevices. Bottom shelf to be 15" above the floor and upper shelf to be 28" above the floor. Unit to be furnished with eight removable pans. Pans to be seamless 304 type stainless with No. 4 finish. Each pan to measure 11-1/2" x 6" x 6" deep.

Unit to be provided with the following accessories:

Accessories

- ACC-42** - Top and Bottom Shelf Covers to each be provided with a double hinged fiberglass folding cover with lock and key. Hinges to be 16 gauge stainless steel. Locks to be chrome plated brass.
- ACC-38** - Circular bumpers. (Add 4" to length and width)
- ACC-41** - Caster brakes on two diagonal casters.
- ACC-47*** - Vinyl Drape

* Specify model □ T-305 or T-407

Continue for

T-407 specifications:

Frame to be of 1" O.D. 16 gauge stainless steel. Casters to be 4" diameter heavy-duty swivel type with 3/4" stems and polyurethane tires.

Shelves to be 16 gauge stainless steel with raised rounded edges on all sides, flanged down to form a 1-1/2" wide channel. Bottom shelf to be 12-1/2" from floor with 14-5/8" clearance between shelves. Shelf corners shaped to fit contour of tubular frame and continuously welded to each leg at all contact points, which eliminates unsanitary crevices. Each shelf to have 15 die-stamped reinforced openings for standard perforated plastic cutlery cylinders.

Unit to be provided with the following accessories:

Accessories

- ACC-49**** - Perforated plastic cutlery cylinders. Approximate capacity per cylinder: 48 knives, 36 forks, or 40 spoons.
- ACC-41** - Caster brakes on two diagonal casters.
- ACC-38** - Circular bumpers. (Add 4" to length and width)
- ACC-47*** - Vinyl Drape

* Specify model □ T-305 or T-407 ** Specify quantity required

**CADDY CORPORATION**

509 Sharptown Road P.O. Box 345
Bridgeport, NJ 08014-0345
Tel: 856-467-4222 Fax: 856-467-5511
internet: www.caddycorp.com



Dish Caddys Single Compartment



Dish and Tray Caddys are designed to make storing, moving, and dispensing dishes easy. At less than 31" high, they can store under counters or serving tables, requiring no extra floor space. Fold away covers permit access to dishes from the top as well as the front of each unit.

 T-130
T-140

 T-135
T-145

 TH-130
TH-140

Model	Dimensions			Plate Qty.*			
	Length	Width	Height	9"	7"	6"	5"
T-130, T-135 TH-130	25 1/2"	15 3/4"	30"	80	120	120	160
T-140, T-145 TH-140	35 1/2"	15 3/4"	30"	120	160	200	240

* Actual capacities vary with shape of object to be dispensed.

Model	Electrical Data			NEMA	
	Volts	φ	Amps	Plug	Outlet**
TH-130 TH-140	120	1	4.1	5-15P	5-15R
	208		2.4	6-15P	6-15R
	240		2.0	6-15P	6-15R

** Outlet not supplied by Caddy Corporation.

General Specifications

Dish Caddy to be Caddy Corporation model
T-_____.

Unit to be constructed of 16 gauge stainless steel with rounded coved corner interior. Frame to be 1" O.D. 16 gauge stainless steel tubing and fitted with 4" diameter heavy-duty swivel type casters with 3/4" stems and polyurethane tires. Stainless steel spacers to be between tubular frame and body to eliminate dirt pockets. Sides to have continuous neoprene bumpers set into stainless steel channel frames. All stainless steel to be type 304 with No. 4 finish and be all welded construction.

Enclosed model specifications:

Dish Caddy to be fitted with folding covers, for sanitary dish storage, of 1/8" thick fiberglass reinforced plastic, fastened with 16 gauge stainless steel hinges. Covers furnished with self-operating positive locking clips. Covers shall not protrude beyond frame of unit when in open position.

Heated model specifications:

Heating element to be 500 watts, mounted under plate storage compartments. Heating element and wiring to be completely concealed. Electrical control box to be stainless steel and installed for easy removal for service. Control box to include infinite Hi-Lo heat control for temperature settings 1 through 9 and a recessed male three-pronged NEMA twist-lock receptacle. Unit to be supplied with a 6'-0" long cord with a NEMA twist-lock female connector.

Heated units only to be certified by Intertek.



Unit to be provided with the following accessories:

Accessories

Partitions - Adjustable stainless steel sliding partitions hold dishes in place and reduce noise especially desirable for use with bowls, irregularly shaped dishes or for use over ramps or rough floors. Partitions hand-adjust to any size dish, may be completely moved to either end or removed to provide full open compartment.

- ACC-23*** - Three compartment partition set.
- ACC-33*** - Four compartment partition set.
- ACC-25**** - Three compartment partition set.
- ACC-35**** - Four compartment partition set.
- ACC-38 - Circular bumpers. (Add 4" to length and width)
- ACC-93 - Stainless steel doors

*** To be used with model □T-130, T-135, & TH-130

**** To be used with model □T-140, T-145, & TH-140

CADDY CORPORATION
509 Sharptown Road P.O. Box 345
Bridgeport, NJ 08014-0345
Tel: 856-467-4222 Fax: 856-467-5511
internet: www.caddycorp.com

Dish & Tray Caddys



Twin Compartment Stores on 2 Sides



Dish and Tray Caddys are designed to make storing, moving, and dispensing dishes and trays easy. At less than 31" high, they can store under counters or serving tables requiring no extra floor space. Fold away covers permit access to dishes from the top as well as the front of each unit.

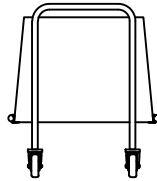

T-150
T-175

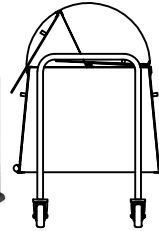

T-160
T-170

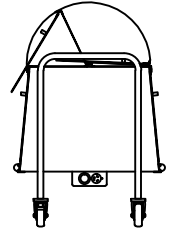

TH-160
TH-170

Dimensions				Plate Qty.*				Tray Qty.*	Electrical Data				NEMA	
Model	Length	Width	Height	9"	7"	6"	5"	10" x 14"	Model	Volts	φ	Amps	Plug	Outlet**
T-150, T-160 TH-160	25 3/4"	26 1/4"	30 1/4"	160	240	240	320	100	TH-160 TH-170	120	1	8.3	5-15P	5-15R
T-170, T-175 TH-170	35 1/2"	26 1/4"	30 1/4"	240	320	400	480	200		208		4.8	5-15P	5-15R
										240		4.1	5-15P	5-15R

* Actual capacities vary with shape of object to be dispensed.

** Outlet not supplied by Caddy Corporation.

General Specifications

Dish & Tray Caddy to be Caddy Corporation model T-_____.

Unit to be constructed of 16 gauge stainless steel with rounded covered corner interior. Frame to be 1" O.D. 16 gauge stainless steel tubing and fitted with 4" diameter heavy-duty swivel type casters with 3/4" stems and polyurethane tires. Stainless steel spacers to be between tubular frame and body to eliminate dirt pockets. Front and back to have continuous neoprene bumpers set into stainless steel channel frames. All stainless steel to be type 304 with No. 4 finish and be all welded construction.

Enclosed model specifications:

Dish & Tray Caddy to be fitted with folding covers, for sanitary dish storage, of 1/8" thick fiberglass reinforced plastic, fastened with 16 gauge stainless steel hinges. Covers furnished with self-operating positive locking clips. Covers shall not protrude beyond frame of unit when in open position.

Heated model specifications:

Heating element to be 1 KW, mounted under plate storage compartments. Heating element and wiring to be completely concealed. Electrical control box to be stainless steel and installed for easy removal for service. Control box to include infinite Hi-Lo heat control for temperature settings 1 through 9 and a recessed male three-pronged NEMA twist-lock receptacle. Unit to be supplied with a 6'-0" long cord with a NEMA twist-lock female connector.

Heated units only to be certified by Intertek.



Unit to be provided with the following accessories:

Accessories

Partitions - Adjustable stainless steel sliding partitions hold dishes in place and reduce noise especially desirable for use with bowls, irregularly shaped dishes or for use over ramps or rough floors. Partitions hand-adjust to any size dish, may be completely moved to either end or removed to provide full open compartment. Two sets are required for each Dish & Tray Caddy.

- ACC-23*** - Three compartment partition set.
- ACC-33*** - Four compartment partition set.
- ACC-25**** - Three compartment partition set.
- ACC-35**** - Four compartment partition set.
- ACC-38 - Circular bumpers. (Add 4" to length and width)
- ACC-93 - Stainless steel doors

*** To be used with model T-150, T-160, & TH-160

**** To be used with model T-170, T-175, & TH-170



CADDY CORPORATION

509 Sharptown Road P.O. Box 345
Bridgeport, NJ 08014-0345
Tel: 856-467-4222 Fax: 856-467-5511
internet: www.caddycorp.com



Multi-Purpose Caddys for Dishes, glasses, cups, saucers & trays



- T-190 enclosed model
- T-195 open model
- TH-190 enclosed model (heated)

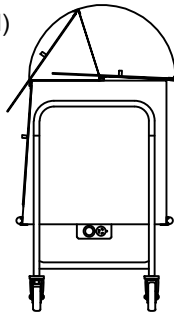

TH-190
Shown

General Specifications

Multi-Purpose Caddy to be Caddy Corporation model T-_____.

Unit to be constructed of 16 gauge stainless steel with rounded covered corner interior and 18 gauge stainless steel undershelf for empty tray and rack storage. Frame to be 1" O.D. 16 gauge stainless steel tubing and fitted with 4" diameter heavy-duty swivel type casters with 3/4" stems and polyurethane tires. Stainless steel spacers to be between tubular frame and body to eliminate dirt pockets. Front and back to have continuous neoprene bumpers set into stainless steel channel frames. All stainless steel to be type 304 with No. 4 finish and be all welded construction.

Enclosed Model Specifications:

Multi-Purpose Caddy for sanitary storage, to be fitted with folding covers of 1/8" thick fiberglass reinforced plastic, fastened with 16 gauge stainless steel hinges. Covers furnished with self-operating positive locking clips. Covers shall not protrude beyond frame of unit when in open position.

Heated Model Specifications:

Heating element to be 1 KW, mounted under storage compartment. Heating element and wiring to be completely concealed. Electrical control box to be stainless steel and installed for easy removal for servicing. Control box to include infinite Hi-Lo heat control for temperature settings 1 through 9 and a recessed male three-pronged NEMA twist-lock receptacle. Unit to be supplied with a 6'-0" long cord with a NEMA twist-lock female connector.

Unit to be provided with the following accessories:

Accessories

- ACC-38 - Circular bumpers. (Add 4" to length and width)

Dimensions			
Model	Length	Width	Height
T-190, T-195, TH-190	39 3/4"	27 1/4"	40 3/4"

Electrical Data			NEMA		
Model	Volts	φ	Amps	Plug	Outlet**
TH-190	120	1	8.3	5-15P	5-15R
	208		4.8	5-15P	5-15R
	240		4.1	5-15P	5-15R

** Outlet not supplied by Caddy Corporation.

Heated units only to be certified by Intertek.



Multi-Purpose Caddy Capacities***

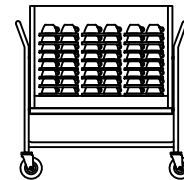

Cups:

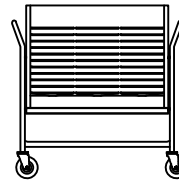

Dishes:

- 300 10" plates
- 300 9" plates
- 600 7" plates
- 750 6" plates

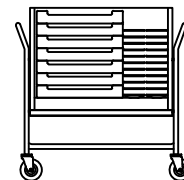

Cups & Saucers:
126 cups in 20" x 20" racks
and 126 saucers

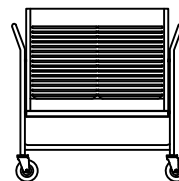

Trays:

160 trays up to 18" x 22"



Cups or Glasses:
120 cups or 216 glasses in
10" x 20" racks

*** Actual capacities vary with shape of object to be dispensed.



* Not available with model TH-190

Cup & Saucer Caddys for Dispensing from underneath beverage stations



- Space saver
- Speeds service
- Keeps aisles clear
- Undershelf for empty cup tray storage

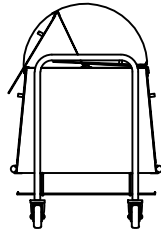

T-170-SU

 T-160-SU
T-170-SU

Dimensions			
Model	Length	Width	Height
T-160-SU	25 $\frac{3}{4}$ "	26 $\frac{1}{4}$ "	30"
T-170-SU	35 $\frac{1}{2}$ "	26 $\frac{1}{4}$ "	30"

General Specifications

Cup & Saucer Caddy to be Caddy Corporation model T-_____.

Unit to be constructed of 16 gauge stainless steel with rounded covered corner interior and wire undershelf for empty tray storage. Frame to be 1" O.D. 16 gauge stainless steel tubing and fitted with 4" diameter heavy-duty swivel type casters with 3/4" stems and polyurethane tires. Stainless steel spacers to be between tubular frame and body to eliminate dirt pockets. Front and back to have continuous neoprene bumpers set into stainless steel channel frames. All stainless steel to be type 304 with No. 4 finish and be all welded construction.

Cup & Saucer Caddy to be fitted with folding covers, for sanitary dish storage, of 1/8" thick fiberglass reinforced plastic, fastened with 16 gauge stainless steel hinges. Covers furnished with self-operating positive locking clips. Covers shall not protrude beyond frame of unit when in open position.

Unit to be provided with the following accessories:

Accessories

- ACC-25 - Three compartment partition set.
- ACC-35 - Four compartment partition set.
- ACC-38 - Circular bumpers. (Add 4" to length and width)

Suggested Cup & Saucer Caddy Combinations

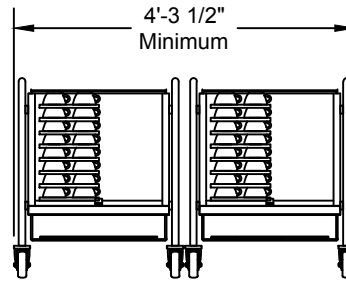

T-160-SU T-160-SU

Total Capacity:**
112 cups
240 saucers

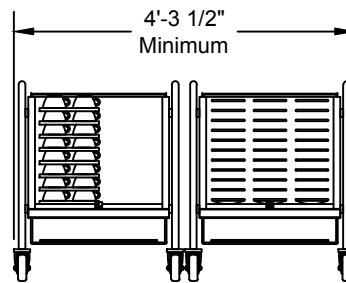

T-160-SU T-160-SU

Total Capacity:**
224 cups

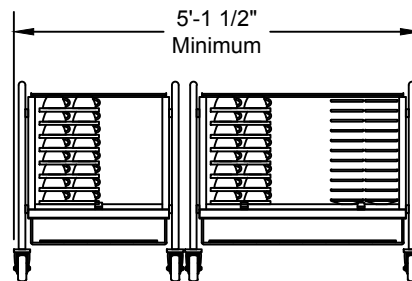

T-160-SU T-170-SU

Total Capacity:**
224 cups
160 saucers

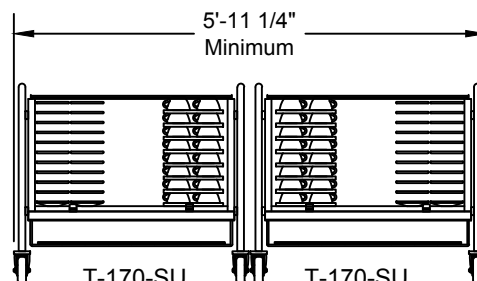

T-170-SU T-170-SU

Total Capacity:**
224 cups
320 saucers

** Actual capacities vary with shape of object to be dispensed.



CADDY CORPORATION

509 Sharptown Road P.O. Box 345
Bridgeport, NJ 08014-0345
Tel: 856-467-4222 Fax: 856-467-5511
internet: www.caddycorp.com

Rack Caddy for

Insulated plastic underplates or
Dome covers



- Space saver
- Mobile
- Convenient

Facilitates dispensing of plastic underplates or dome covers in the central tray make-up procedure. Rack Caddys are furnished with removable cradles. Cradles can be placed on top of standard 20" x 20" dishwasher racks for washing in rack-type dishwashing machines. Soiled underplates can be loaded into the cradles for washing and removed, in bulk, to the Rack Caddy for storage and reuse. Spare cradles may be ordered to eliminate repeated cradle transfer.

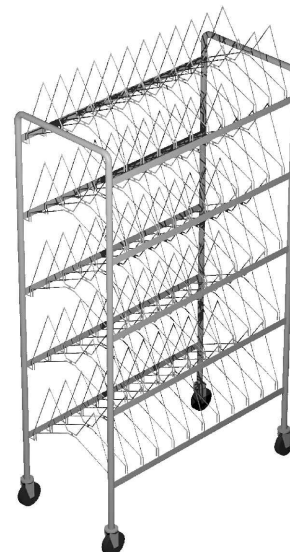
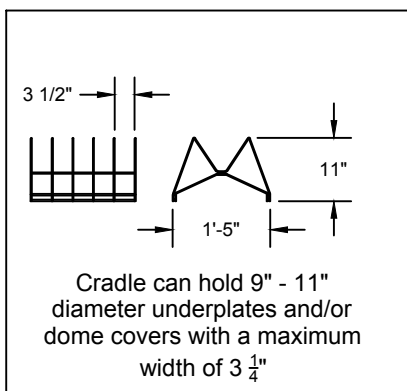
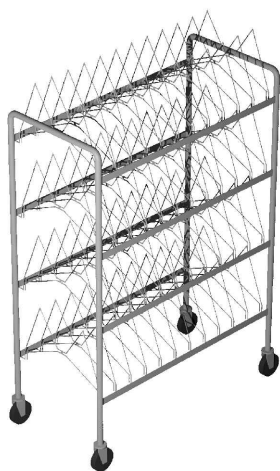
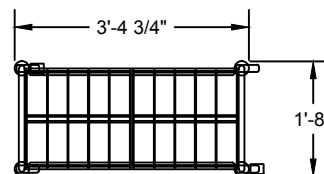
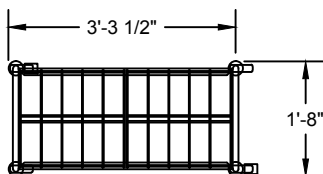

T-540
Capacity:
240 underplates
80 dome covers
Height □ 5' 1-1/4"

T-545
Capacity:
300 underplates
100 dome covers
Height □ 6' 1-3/4"

General Specifications

Mega-Temp Rack Caddy to be Caddy Corporation model T-_____.

Frame to be of 1" O.D. 16 gauge stainless steel tubing with 3/8" diameter stainless steel rod supports. Angle frames supporting cradles to be 12 gauge stainless steel all welded and polished construction. Set of two removable cradles for each shelf to be of welded 3/16" diameter rod entirely plastic finished. Clearance between cradles to be 3-5/16" and clearance between shelves to be 12-3/16". Casters to be 4" diameter heavy-duty swivel type casters with 3/4" stems and polyurethane tires. Two diagonal casters to have foot brakes.

Unit to be provided with the following accessories:

Accessories

- ACC-38 - Circular bumpers. (Add 4" to length and width)
- ACC-26* - Extra plastic cradle

* Two required per shelf

CADDY CORPORATION
509 Sharptown Road P.O. Box 345
Bridgeport, NJ 08014-0345
Tel: 856-467-4222 Fax: 856-467-5511
internet: www.caddycorp.com

Bussing Caddys for dishes, silver, glasses, tray, and refuse



- Saves time
- Saves labor
- Provides faster entry to dishwashing machine

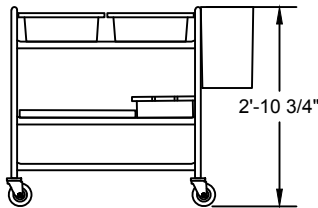
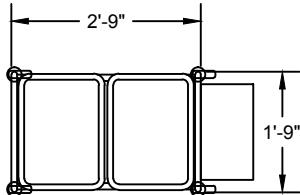

T-209

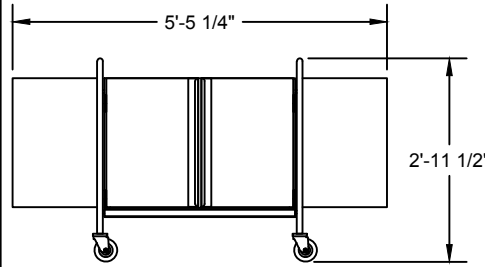
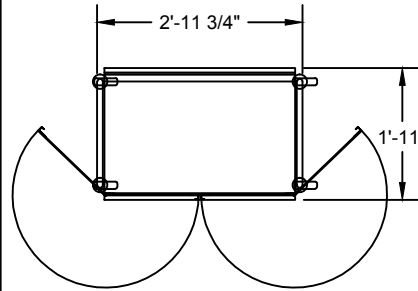

T-214



General Specifications

Bussing Caddy to be Caddy Corporation model T-209.

Frame to be of 1" O.D. 16 gauge stainless steel. Unit to have three shelves of 18 gauge stainless steel with raised rounded edges on all sides, flanged down to form a 1-1/2" wide channel. Shelf corners shaped to fit contour of tubular frame and continuously welded to each leg at all contact points which eliminates unsanitary crevices. Casters to be 4" diameter heavy-duty swivel type with 3/4" stems and polyurethane tires.

Unit to include two 15" x 20" x 5" plastic dish boxes (PL-1520), one 10" x 18" cutlery pan, one 20" x 20" x 1-1/2" stainless steel glass rack tray, and one 15-1/2" x 6-1/2" x 16" removable stainless steel refuse container.

Unit to be provided with the following accessories:

Accessories

- ACC-38 - Circular bumpers. (Add 4" to length and width)
- ACC-41 - Caster brakes on two diagonal casters.

General Specifications

Bussing Caddy to be Caddy Corporation model T-214.

Unit to be constructed of 16 gauge stainless steel with rounded coved corner interior and two 18 gauge stainless steel shelves. Frame to be 1" O.D. 16 gauge stainless steel tubing and fitted with 4" diameter heavy-duty swivel type casters with 3/4" stems and polyurethane tires. Stainless steel spacers to be between tubular frame and body to eliminate dirt pockets. Front and back to have continuous neoprene bumpers set into stainless steel channel frames. All stainless steel to be type 304 with No. 4 finish and be all welded construction. Front to have two hinged acrylic plate doors with full height stainless steel pull handles and magnetic catch latch.

Unit to be provided with the following accessories:

Accessories

- ACC-38 - Circular bumpers. (Add 4" to length and width)
- ACC-41 - Caster brakes on two diagonal casters.



**Transfer and Storage Caddys
for Racks and Trays**

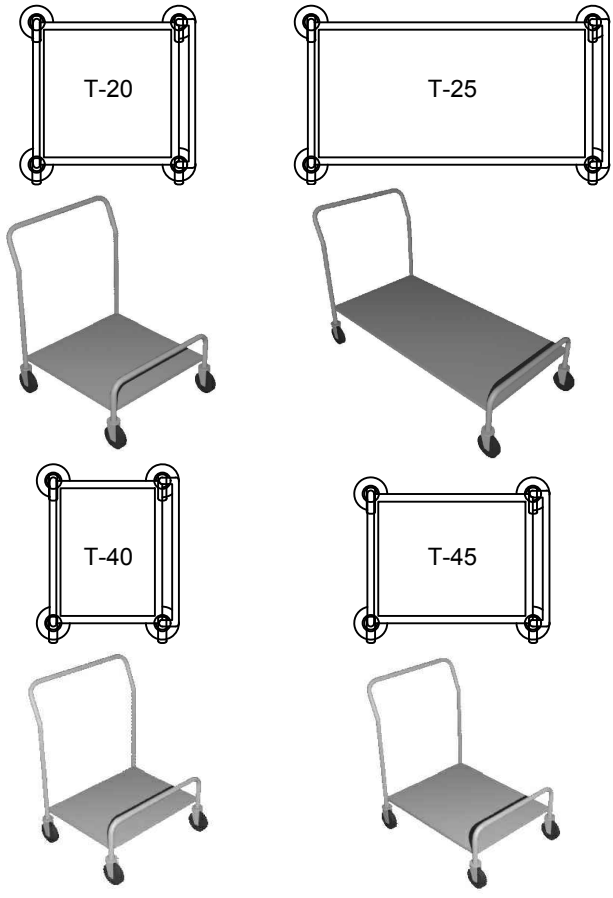

Dimensions				
Model	Length	Width	Height	Rack/Tray
T-20	26 1/2"	26 1/2"	29 1/4"	20" x 20"
T-25	47 1/2"	26 1/2"	29 1/4"	20" x 20" *
T-40	21 1/2"	26 1/2"	29 1/4"	15" x 20"
T-45	29 1/2"	24 1/2"	29 1/4"	16" x 22"

* Accommodates two stacks

General Specifications

Rack and/or Tray Caddy to be Caddy Corporation model T-_____.

Frame to be of 1" O.D. 16 gauge stainless steel. Shelf to be 8" (T-25 to be 10") above the floor, of 18 gauge stainless steel with raised rounded edges on all sides, flanged down to form a 1-1/2" wide channel. Shelf corners shaped to fit contour of tubular frame and continuously welded to each leg at all contact points which eliminates unsanitary crevices. Casters to be 4" diameter heavy-duty swivel type with 3/4" stems and polyurethane tires. Tubular frame to be fitted with 4 circular bumpers.

Unit to be provided with the following accessories:

Accessories

- ACC-41 - Caster brakes on two diagonal casters.

T-50 Rack Caddy can accommodate up to five racks of cups glasses or bowls.

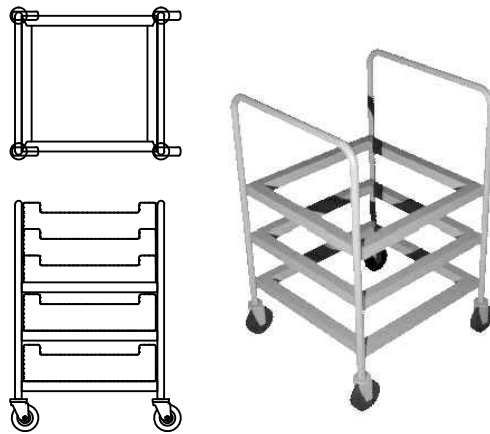

T-50

Dimensions				
Model	Length	Width	Height	Rack
T-50	22 1/2"	21 1/2"	34 3/4"	20" x 20"

General Specifications

Rack Caddy to be Caddy Corporation model T-50.

Frame to be of 1" O.D. 16 gauge stainless steel. Rack slides to be 14 gauge 1-1/2" x 1-1/2" stainless steel angles mounted on back and both sides. Rack slides to be continuously welded to each leg at all contact points which eliminates unsanitary crevices. Casters to be 4" diameter heavy-duty swivel type with 3/4" stems and polyurethane tires.

Unit to be provided with the following accessories:

Accessories

- ACC-38 - Circular bumpers. (Add 4" to length and width)

CADDY CORPORATION
 509 Sharptown Road P.O. Box 345
 Bridgeport, NJ 08014-0345
 Tel: 856-467-4222 Fax: 856-467-5511
 internet: www.caddycorp.com

**Transfer and Storage Caddys
for Racks and Trays**



T-201-A



T-201-A-LB



T-201-B

Dimensions				
Model	Length	Width	Height	Trays
T-201-A	33"	21"	34 ³ / ₄ "	14" x 18"
T-201-A-LB	33"	21"	24 ³ / ₄ "	14" x 18"
T-201-B	37"	25"	34 ³ / ₄ "	16" x 22"

General Specifications

Rack and/or Tray Caddy to be Caddy Corporation model T-_____.

Frame to be of 1" O.D. 16 gauge stainless steel. Shelf to be 8" above the floor, of 18 gauge stainless steel with raised rounded edges on all sides, flanged down to form a 1-1/2" wide channel. Shelf corners shaped to fit contour of tubular frame and continuously welded to each leg at all contact points which eliminates unsanitary crevices. Casters to be 4" diameter heavy-duty swivel type with 3/4" stems and polyurethane tires.

Unit to be provided with the following accessories:

Accessories

- ACC-38** - Circular bumpers. (Add 4" to length and width)
- ACC-41** - Caster brakes on two diagonal casters.

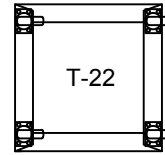

Dimensions				
Model	Length	Width	Height	Rack
T-22	22 ¹ / ₄ "	22 ¹ / ₄ "	8"	20" x 20"

General Specifications

Rack and/or tray Caddy to be Caddy Corporation model T-22.

Frame to be 14 gauge stainless steel angles. Casters to be 4" diameter heavy-duty platform swivel type with polyurethane tires.

Unit to be provided with the following accessories:

Accessories

- ACC-50** - Perimeter bumpers with replaceable corner bumpers. (Add 1-1/4" to length and width)
- ACC-52** - Vertical corner bumpers only. Easy to replace. (Add 1-1/4" to length and width)

CADDY CORPORATION
 509 Sharptown Road P.O. Box 345
 Bridgeport, NJ 08014-0345
 Tel: 856-467-4222 Fax: 856-467-5511
 internet: www.caddycorp.com



CADDY CORPORATION

Food Service Equipment

Air Systems

Utility Make-Up Tables

Utility Make-Up Tables
Regular or Slimline



- Rigid construction
- Stainless steel
- Easy to clean
- Provides good working surface

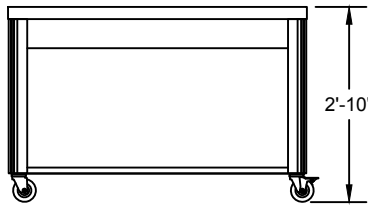
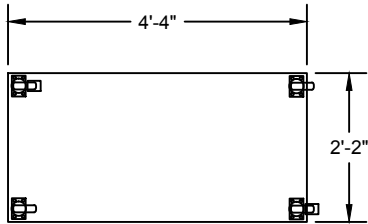

TF-600
Regular

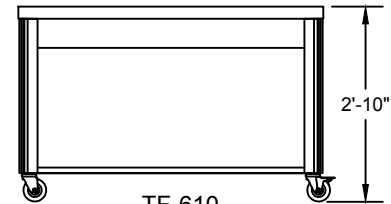
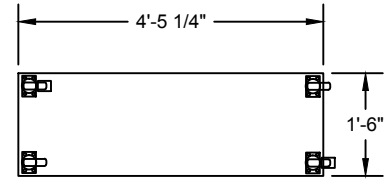

TF-610
Slimline

General Specifications

Utility Make-Up Table to be Caddy Corporation model TF-_____.

Solid top to be reinforced 18 gauge stainless steel turned down into 2" wide channel edges with corners welded.

Frame structure to consist of 18 gauge stainless steel formed pedestals to be reinforced with 16 gauge stainless steel channels, to have full height extruded plastic vertical bumpers. Body enclosure to be 16 gauge stainless steel with 18 gauge stainless steel reinforced undershelf. Casters are to be 4" diameter heavy duty, double ball bearing, swivel type with polyurethane tires. Two casters to be provided with foot brakes.

Unit to be provided with the following accessories:

Accessories

- A-15 (A-16)*** - Push Handle to be 1" O.D. 16 gauge stainless steel tubing with two 16 gauge stainless steel support brackets and 3" neoprene donut bumpers.
- A-69 (A-88)*** - Folding Tray Slide To be 1" square 16 gauge stainless steel tubing, 10" overall width, welded to intermediate lateral supports and mounted on folding brackets. Slide to be removable.

Accessories continued:

- A-73 (A-90)*** - Folding Work Shelf to be 16 gauge stainless steel with all edges turned down and welded corners, 10" overall width, mounted on folding brackets. Shelf to be removable.
- A-65 (A-86)*** - Overshelf to be 16 gauge stainless steel, 10" wide with channel edges. Supports to be 1" x 1/4" flat bar. Shelf to be located rear of unit 15" above work top.
- A-61 (A-84)*** - Sneeze Protector** to be 3/16" clear polycarbonate plastic, suspended from 16 gauge stainless steel overshelf.
- ACC-52** - Vertical corner bumpers only. Easy to replace. (Add 1 1/4" to length and width)

* Use number in parentheses when ordering for TF-610 Slimline
** Includes overshelf

CADDY CORPORATION
509 Sharptown Road P.O. Box 345
Bridgeport, NJ 08014-0345
Tel: 856-467-4222 Fax: 856-467-5511
internet: www.caddycorp.com

Utility Make-Up Table
Bread, Toast, Rolls

- T-790 features a solid top shelf for toasters and roll warmer*

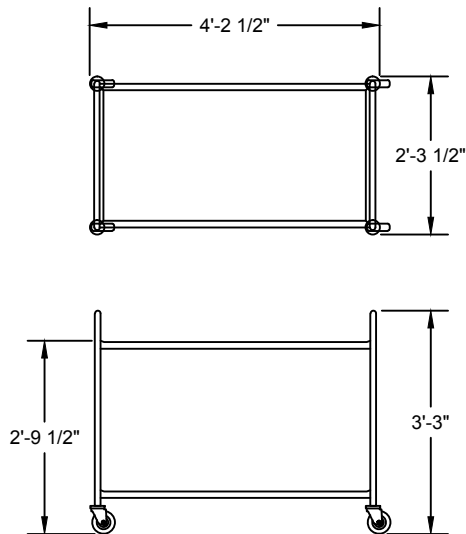

T-790

* Toasters and roll warmer not included

**General Specifications**

Utility Make-Up Table to be Caddy Corporation model T-790.

Frame to be 1" O.D. 16 gauge stainless steel tubing and fitted with 4" diameter heavy-duty swivel type casters with stems and polyurethane tires.

Shelves to have raised rounded edges on all sides with all corners continuously welded to legs at all contact points. Both shelves to be reinforced with stainless steel channels. Lower shelf to accommodate a two drawer roll warmer.

Unit to be provided with the following accessories:

Accessories

- ACC-41** - Caster brakes on two diagonal casters.
- ACC-38** - Circular bumpers. (Add 4" to length and width)

CADDY CORPORATION
509 Sharptown Road P.O. Box 345
Bridgeport, NJ 08014-0345
Tel: 856-467-4222 Fax: 856-467-5511
internet: www.caddycorp.com

Utility Caddys All-Purpose Trucks

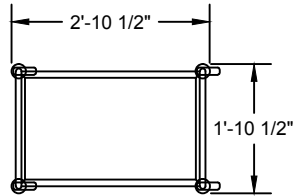
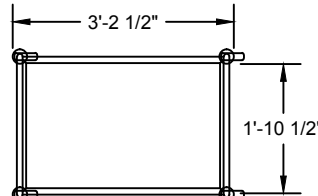
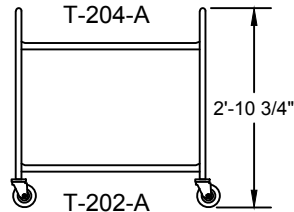
 T-202-A
T-203-A
T-204-A

 T-202-B
T-203-B
T-204-B

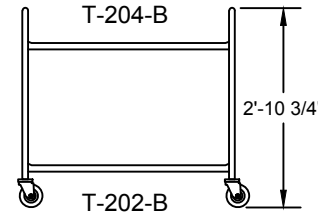
T-202-A

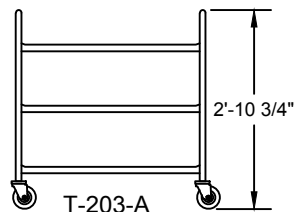

T-202-B



T-203-A

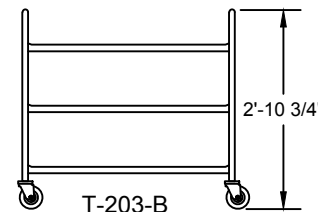

T-203-B

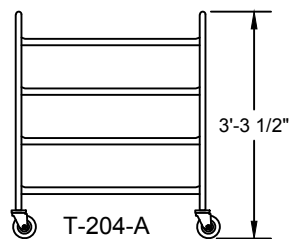

T-204-A

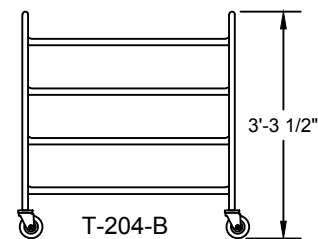

T-204-B



General Specifications

Utility Caddy to be Caddy Corporation model _____.

Frame to be of 1" O.D. 16 gauge stainless steel tubing. Unit to have two shelves. Shelves to be 18 gauge stainless steel with raised rounded edges on all sides, flanged down to form a 1 1/2" wide channel. Shelf corners shaped to fit contour of tubular frame and continuously welded to each leg at all contact points which eliminates unsanitary crevices. Both shelves to be reinforced with stainless steel channels.

Casters to be 4" diameter heavy-duty swivel type with 3/4" stems and polyurethane tires.

Unit to be provided with the following accessories:

Accessories

- ACC-38** - Circular bumpers. (Add 4" to length and width)
- ACC-41** - Caster brakes on two diagonal casters.
- ACC-63** - 5" diameter swivel casters with polyurethane tires in lieu of 4" diameter swivel casters. (Add 1 1/8" to height)
- PL-1520** - 15" x 20" x 5" plastic tote box for napkin wrapped silverware.

CADDY CORPORATION
509 Sharptown Road P.O. Box 345
Bridgeport, NJ 08014-0345
Tel: 856-467-4222 Fax: 856-467-5511
internet: www.caddycorp.com

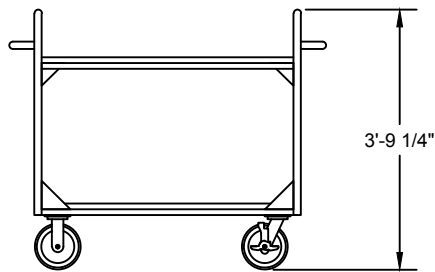
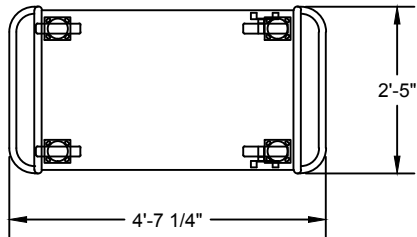
Utility Caddys
All-Purpose Trucks**Correctional Utility Caddy****General Specifications**

Correctional Utility Caddy to be Caddy Corporation model T-202-C.

Frame to be of 1 $\frac{1}{4}$ " O.D. 16 gauge stainless steel tubing reinforced with 12 gauge stainless steel corner gussets. Unit to have two shelves. Shelves to be 12 gauge stainless steel with 1" raised edge on three sides and 1" turned down edge on the front. Shelves and gussets to be continuously welded at corners which eliminates unsanitary crevices. Both shelves to be reinforced with 12 gauge stainless steel channels. Unit to have a 1 $\frac{1}{4}$ " O.D. 16 gauge stainless steel tubular handle at each end that wraps around the rear creating a back stop.

Casters to be 8" diameter heavy-duty, semi-pneumatic, modulus-type tread. Two to be swivel type and two to be rigid type. Swivel type casters to be provided with foot brakes.

CADDY CORPORATION
509 Sharptown Road P.O. Box 345
Bridgeport, NJ 08014-0345
Tel: 856-467-4222 Fax: 856-467-5511
internet: www.caddycorp.com



CADDY CORPORATION

Food Service Equipment

Air Systems

Miscellaneous Caddys

Miscellaneous Caddys Kitchen, Mixer, Slicer, Utensil



T-242
Mixer Caddy



T-243-A
T-243-B
Slicer Caddy



T-249-A
Kitchen Caddy

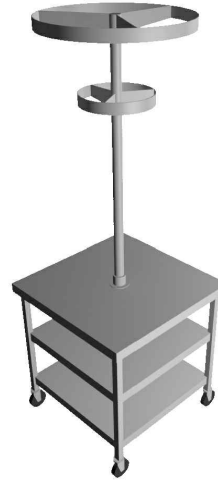

T-247
Utensil Caddy



T-247-P
Utensil Rack

Dimensions			
Model	Length	Width	Height
T-242	30"	24"	70"
T-243-A	26 $\frac{1}{4}$ "	30"	30"
T-243-B	26 $\frac{1}{4}$ "	30"	26"
T-247	30"	30"	84"
T-249-A	30"	30"	34 $\frac{1}{4}$ "

General Specifications

Caddy to be Caddy Corporation model T-_____.

Top to be 18 gauge stainless steel turned down into 2" wide channel edges, with corners welded. Top to be reinforced with a 12 gauge stainless steel plate turned down 1" on each side.

Legs to be 1 $\frac{1}{4}$ " 16 gauge stainless steel square tubing and fitted with 5" diameter, heavy duty, double ball bearing, swivel type casters with polyurethane tires. Two casters to be provided with foot brakes.

Continue for:

T-242 Specifications:

Mixer Caddy to have one lower shelf of 16 gauge stainless steel turned down into 2" channel edges, notched to fit contour of legs, and continuously welded at all contact points.

One rear leg to extend through top to a height of 70", enclosed at top, and fitted with five part rack pegs. Pegs to be 6" long of $\frac{5}{16}$ " stainless steel rod. First peg to be set 30" above top of Caddy. Pegs to be spaced 3" apart and staggered, with three facing front and two facing inward. All pegs to be sloped upward 2". Part rack to be removable for shipping.

Continue for:

T-243 Specifications:

Slicer Caddy to have three sets of 14 gauge stainless steel channel slides spaced to accommodate 18" x 26" pans in position to catch food directly from slicer.

Continue for:

T-247 Specifications:

Utensil Caddy to have two lower shelves of 16 gauge stainless steel turned down into 2" channel edges, notched to fit contour of legs, and continuously welded at all contact points. Shelves to be spaced 10" from top to bottom.

Utensil racks to be of 2" wide 10 gauge stainless steel bar with stainless steel cross braces. Upper utensil rack to be 25 $\frac{1}{2}$ " diameter and lower utensil rack to be 13" diameter. Racks to be fitted with 15 double-sided sliding utensil hooks, 10 on upper rack and 5 on lower rack. Both circular utensil racks revolve, by hand, independently of each other. Utensil racks supported by 1 $\frac{5}{8}$ " O.D. stainless steel tubing. Tubing to pass through Caddy top and to be bolted to middle shelf. Utensil rack to be removable for shipping.

Continue for:

T-247-P Specifications:

Utensil rack to be as specified as part of T-247 without caddy or shelves. 1 $\frac{5}{8}$ " O.D. stainless steel tubing to be 74" long with intermediate mounting flange and bottom mounting bolt.

Continue for:

T-249-A Specifications:

Kitchen Caddy to have two lower shelves of 16 gauge stainless steel turned down into 2" channel edges, notched to fit contour of legs, and continuously welded at all contact points.

CADDY CORPORATION
 509 Sharptown Road P.O. Box 345
 Bridgeport, NJ 08014-0345
 Tel: 856-467-4222 Fax: 856-467-5511
 internet: www.caddycorp.com

Cashier Caddys Mobile with folding tray slides

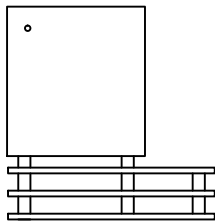
TOP VIEW

T-251-L T-251-R*
T-256-L T-251-R*
* Right hand model has tray
slide on opposite side of cashier

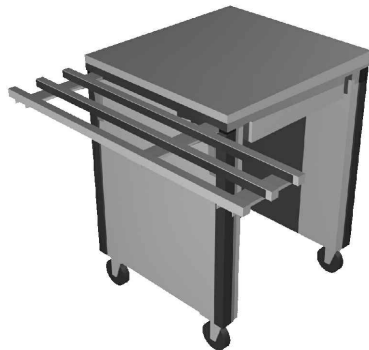
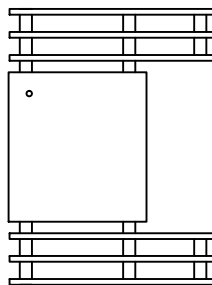
TOP VIEW

T-251-L-R
T-256-L-R



General Specifications

Cashier Caddy to be Caddy Corporation model
T-_____.

Unit to have all stainless steel exterior. Top to be 18 gauge stainless steel turned down into 2" wide channel edges, with corners welded. Top to be reinforced to accommodate cash register and to have 1" diameter hole for power cord.

Frame structure to consist of 18 gauge stainless steel formed pedestals to be reinforced with 16 gauge stainless steel channels, to have full height extruded plastic vertical bumpers. Casters are to be 4" diameter heavy duty, double ball bearing, swivel type with polyurethane tires and foot brakes.

Tray slide to be 11" wide x 36" long, made of three 1" square tubes with enclosed ends and two heavy duty, die cast, chrome plated folding brackets. Foot rail to be of 1 1/4" O.D. 16 gauge stainless steel tubing.

Continue for:

T-251 Specifications:

Unit to have cash drawer furnished with five coin tills and five currency compartments with hinged bill weights. Drawer to be fitted with a lock and roller mechanism for easy operation.

Continue for:

T-256 Specifications:

Unit to have cash drawer, 2 1/4" deep of stainless steel construction, with single open storage compartment to accommodate a portable cash box. Drawer to be fitted with a lock and roller mechanism for easy operation.

Dimensions

Model	Table only			With tray slide	
	Length	Width	Height	Length	Width
T-251-L T-251-R	24"	26"	34"	36 1/4"	37"
T-256-L T-256-R	24"	26"	34"	36 1/4"	37"
T-251-L-R T-256-L-R	24"	26"	34"	36 1/4"	48"

Suggested arrangement where two cashiers lines are required

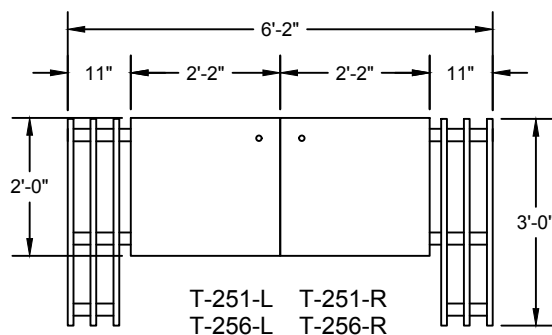

CADDY CORPORATION
509 Sharptown Road P.O. Box 345
Bridgeport, NJ 08014-0345
Tel: 856-467-4222 Fax: 856-467-5511
internet: www.caddycorp.com



CADDY CORPORATION

Food Service Equipment

Air Systems

Starter Caddys

Starter Caddys for central tray make-up

**SERIES T-560****SERIES T-563****SERIES T-570****SERIES RH-T-565**

ACCESSORIES (optional extra)

- Revolving Leg Bumpers ACC-38.**
Adds 4" to overall length and width.
- Plastic Tote Box PL-1520.**
15" x 20" x 5" for napkins and wrapped silverware .

Mobile storage-dispensing aids

Equipped with compartmented bins and shelves

SPECIFICATIONS

SERIES T-560 (For wrapped silverware, condiments, place mats).

Starter Caddy to be **Series T-560** as manufactured by Caddy Corporation of America, to be 38" long x 26" wide x 55" high. Frame of 1" O.D. 16 ga s.s. tubular construction with two shelves of 18 ga s.s. with raised rounded edges on all sides flanged down to form a 1½" wide channel. Shelf corners shaped to fit contour of tubular frame eliminating unsanitary crevices and continuously welded to legs at all contact points. Both shelves to be reinforced with s.s. channels. Casters 4" heavy duty double ball bearings swivel type with ¾" solid stems and polyurethane tires. Foot brakes on 2 diagonal casters. Sloped overhead shelf of 16 ga s.s., welded construction, approx. 19" wide with cutouts for, and provided with, six s.s. pans three 10" x 6" x 6" and three 6" x 6" x 6". Raised, ⅜" dia. welded s.s. retainer rails to be provided for place mats. Shelf supported by solid 16 ga s.s. end supports. All s.s. to be type 304 No. 4 finish.

SERIES T-563 (For pre-packaged items in carton dispenser such as plastic flatware, condiments and place mats / Designed for hospitals and nursing homes up to 150 beds.)

Starter Caddy to be **Series T-563** as manufactured by Caddy Corporation of America, to be 38" long x 26" wide x 52" high. Frame of 1" O.D. 16 ga s.s. tubular construction with two shelves of 18 ga s.s. with raised rounded edges on all sides flanged down to form a 1½" wide channel. Shelf corners shaped to fit contour of tubular frame eliminating unsanitary crevices and continuously welded to legs at all contact points. Shelves to be reinforced with s.s. channels. Casters 4" heavy duty double ball bearings swivel type with ¾" solid stems and polyurethane tires. Foot brakes on 2 diagonal casters. Superstructure to consist of two shelves with 16 ga s.s. ends. Lower shelf to be sloped with cutouts for and provided with three s.s. pans, one-third size. Raised ⅜" diameter welded s.s. retainer rails to be provided for place mats. All s.s. to be type 304 No. 4 finish.

SERIES T-570 (For wrapped silverware, condiments, place mats. Designed to straddle tray make-up conveyor.)

Starter Caddy to be **Series T-570** as manufactured by Caddy Corporation of America, to be 69 1/2" long x 27" wide x 65" high. End frame of 1" O.D. 16 ga s.s. tubular splayed construction with cross-railing and mounted on 4" double ball bearing swivel casters with polyurethane tires. Unit to be suitable for straddling mobile equipment or conveyor. Two casters on operator's side to have foot brakes. Superstructure to consist of two shelves with 14 ga s.s. ends and upper shelf. Low shelf of 12 ga s.s. to be tilted for convenient view with cutout for 6 s.s. pans 4" deep. Three pans one third size, two pans one half size, and one full size pan. (Pans optional extra.)

SERIES RH-T-565 (For wrapped silverware, condiments, place mats).

Starter Caddy to be **Series RH-T-565** as manufactured by Caddy Corporation of America, to be 37" long x 23" wide x 51" high. Frame of 1" O.D. 16 ga s.s. tubular construction with undershelf of 18 ga s.s.. Right hand side of unit to have top and intermediate shelves to accommodate silverware bins and place mats. All shelves to have raised rounded edges on all sides with corners notched and continuously welded to legs at all contact points. Left hand side of unit to have self-leveling platform for trays up to 16" x 22". Housing and platform of self-leveling mechanism to be heavy aluminum, suspended by four s.s. cables to provide level and stable surface. Cables to have full-length self-lubricating plastic shields. Entire spring mechanism to be equipped with ball bearings and designed for easy calibration. Platform to be removable for access and calibration. Unit to be provided with 16 ga s.s. sloped shelf mounted overhead with cutout for 3 s.s. pans 4" deep. Two pans to be one third size and one full sized. (Pans optional extra.) Overshelf to have welded corners and to be supported by solid 16 ga s.s. ends. Casters of plated finish 4" double ball bearing all swivel with polyurethane tires, two diagonal casters with foot brakes.

**CADDY CORPORATION**

509 Sharptown Road P.O. Box 345
Bridgeport, NJ 08014-0345
Tel: 856-467-4222 Fax: 856-467-5511
internet: www.caddycorp.com